

Guide to the OLE Select and Acquire Module

Table of Contents

Introduction	xi
1. Accessing Purchasing and Accounts Payable Functions	1
2. Batch Processes	2
3. Ordering Materials: Standard Transactional E-Docs	3
Requisition Search	3
Requisition	3
Getting Started	3
Document Layout	5
Purchase Order Search	34
Purchase Order	34
Getting Started	35
Document Layout	35
Process Overview	55
Purchase Order Amend	62
Document Layout	62
Process Overview	63
Purchase Order Payment Hold	66
Document Layout	66
Process Overview	66
Purchase Order Remove Payment Hold	68
Document Layout	68
Process Overview	69
Purchase Order Void	70
Document Layout	71
Process Overview	71
Purchase Order Close	73
Document Layout	73
Process Overview	74
Purchase Order Reopen	75
Document Layout	75
Process Overview	76
Order Holding Queue	78
4. Paying for Materials: Standard Transactional E-Docs	81
Invoice Search	81
Invoice	81
Getting Started	81
Document Layout	83
Process Overview	89
Vendor Credit Memo Search	89
Vendor Credit Memo	89
Document Layout	89
Process Overview	99
Example	105
5. Receiving Materials: Standard Transactional E-docs	106
Monograph Receiving Search	106
Monograph Receiving (Line Item Receiving)	106
Getting Started	107
Document Layout	107
Process Overview	114
Receiving Queue: Express Receiving	117
Receive	118

Guide to the OLE Select
and Acquire Module

Create Receiving	119
Pay	119
Receive and Pay	121
Serials Receiving Transaction	122
Getting Started	122
Document Overview	122
6. Fund	126
General Ledger	126
Fund Lookup	128
Query Available Account Balances: Requisition (Purchase Order, Payment Request)	
Line Item	129
Lookup Criteria	130
Search Results	131
Flexible Offset Options	131
Flexible Banking Offsets	132
Flexible Offsets by Account	132
Budget Adjustment Search	133
Budget Adjustment	133
Document Layout	134
Process Overview	138
Transfer of Funds Search	141
Transfer of Funds	141
Document Layout	142
Process Overview	142
7. Acquisitions: Standard Transactional Documents	146
Payment Request Search	146
Payment Request	146
Getting Started	147
Search for Purchase Order Numbers	147
Document Layout	147
Process Overview	162
General Error Correction	172
Document Layout	172
Process Overview	173
Example	175
Disbursement Voucher	177
Document Layout	177
Process Overview	187
E-Resource	190
Document Layout	191
Process Overview	200
E-Resource Search	201
Process Overview	202
8. COA Attribute Maintenance E-Docs	203
Constraint Type	203
Document Layout	203
Fund Group	204
Document Layout	204
Object Consolidation	205
Document Layout	206
Object Level	206
Document Layout	207
Object Sub-Type	208
Document Layout	208

Guide to the OLE Select
and Acquire Module

Object Type	209
Document Layout	209
Restricted Status	210
Document Layout	210
Stewardship Requirement	211
Document Layout	211
Sub-Fund Group	212
Document Layout	212
Sub-Fund Group Type	213
Document Layout	214
Sufficient Funds Code	214
Document Layout	215
Sufficient Funds Check Type	215
Document Layout	216
9. Standard COA E-Docs	217
Managing COA Documents	217
Initiating Chart of Account Structures	218
Creating Funds: OLE Chart of Accounts	218
Global COA Documents	219
Edit List of xxx Tab	220
Account	221
Document Layout	222
Process Overview	230
Account Global	233
Document Layout	233
Process Overview	235
Object Code	237
Document Layout	238
Process Overview	241
Object Code Global	242
Document Layout	243
Process Overview	244
Organization	246
Document Layout	247
Process Overview	248
Sub-Account	250
Document Layout	250
Process Overview	252
Sub-Object Code	253
Document Layout	254
Process Overview	255
Sub-Object Code Global	256
Document Layout	257
Process Overview	259
10. Vendor (and Document Searches)	262
Vendors	262
Special Navigation Features	262
Document Layout (for Create New Vendor & Create Division)	265
Process Overview	281
Document Store Discovery	282
Performing a Document Store Search	283
OLE Instance Searching	288
Acquisitions Search	290
11. Vendor Attribute Maintenance E-Docs	291

Guide to the OLE Select
and Acquire Module

Address Type	291
Document Layout	292
Campus	292
Document Layout	293
Commodity Code	294
Document Layout	295
Contact Type	297
Document Layout	298
Contract Manager	298
Document Layout	299
Cost Source	299
Document Layout	300
Ownership Type	300
Document Layout	301
Ownership Type Category	301
Document Layout	302
Payment Terms Type	302
Document Layout	303
Phone Type	304
Document Layout	304
Shipping Payment Terms	305
Document Layout	305
Shipping Special Conditions	306
Document Layout	306
Shipping Title	307
Document Layout	307
Supplier Diversity	308
Document Layout	308
Vendor Inactive Reason	309
Document Layout	309
Vendor Search Alias Type	310
Document Layout	310
Vendor Transmission Format	311
Document Layout	311
Vendor Transmission Type	312
Document Layout	312
Vendor Type	312
Document Layout	313
12. Importing Records	315
Staff Upload	315
Vendor EOCRs	315
Process Overview	316
Load Reports	317
Getting Started	317
Document Layout	317
Process Overview	321
13. Purchasing/Accounts Payable Maintenance E-Docs	322
Billing Address	323
Document Layout	323
Carrier	324
Document Layout	324
Category	325
Document Layout	325
Delivery Required Date Reason	326

Guide to the OLE Select
and Acquire Module

Document Layout	326
Electronic Invoice Item Mapping	327
Document Layout	327
Exception Type	328
Document Layout	328
Format	329
Document Layout	329
Funding Source	329
Document Layout	330
Invoice Sub Type	330
Document Layout	331
Invoice Type	331
Document Layout	332
Item Price Source	332
Document Layout	333
Item Reason Added	333
Document Layout	334
Item Type	334
Document Layout	335
Method of PO Transmission	335
Document Layout	336
Negative Payment Request Approval Limit	336
Document Layout	337
Note Type	338
Document Layout	338
Organization Parameter	339
Document Layout	339
Order Type	340
Document Layout	340
Payment Method	340
Document Layout	341
Payment Request Auto Approve Exclusions	341
Document Layout	342
Purchase Order Contract Language	342
Document Layout	343
Purchase Order Item Status	344
Document Layout	344
Purchase Order Quote Language	345
Document Layout	345
Purchase Order Quote List	346
Document Layout	346
Purchase Order Quote Status	348
Document Layout	349
Purchase Order Vendor Choice	349
Document Layout	350
Receiving Address	350
Document Layout	351
Receiving Threshold	352
Document Layout	353
Recurring Payment Frequency	354
Document Layout	354
Recurring Payment Type	355
Document Layout	355
Request Source Type	356

Guide to the OLE Select
and Acquire Module

Document Layout	356
Requisition Source	357
Document Layout	357
Sensitive Data	358
Document Layout	358
Vendor Stipulation	359
Document Layout	359
Licensing Requirement	360
Document Layout	360
Authentication Type	361
Document Layout	361
Access Location	362
Document Layout	362
E-Resource Status	363
Document Layout	363
Package Type	364
Document Layout	364
Package Scope	365
Document Layout	365
Material Type	366
Document Layout	366
Access Type	366
Document Layout	367
Content Type	367
Document Layout	368
Payment Type	368
Document Layout	369
Request Priority	369
Document Layout	370
General Ledger Introduction	370
GL Inquiries: Basic Information	373
Entering Lookup Criteria	373
Meaning of Dollar Accumulators	373
Drilldowns	374
Include or Exclude Pending Entries, Unapproved Entries, and GL Entries	375
General Ledger Entry	376
Lookup Criteria	376
Search Results	377
Available Balances	377
Lookup Criteria	378
Search Results	378
Query Available Account Balances: Requisition (Purchase Order, Payment Request) Line Item	379
Globally Protected Field	381
Document Layout	381
14. Licensing Overview	383
Licensing e-documents	383
15. Standard Licensing E-Docs	385
Initiate License Workflow	385
License Request	385
Getting Started	386
Document Layout	386
Business Rules	392
Routing	392

16. License Maintenance Documents	399
.....	399
Roles& Permissions	399
Manage Checklist	399
Document Layout	400
Process Overview	400
License Request Status	401
Document Layout	402
License Request Current Location	403
Document Layout	403
License Request Type	404
Document Layout	404
17. Agreement Maintenance Documents	405
Agreement Documents Type	405
Document Layout	405
Agreement Method	406
Document Layout	406
Agreement Status	407
Document Layout	407
Agreement Type	408
Document Layout	408
18. Appendix	409
Terms and Definitions	409
Select And Acquire Roles	411
Maintenance Documents Permissions and Routing	414
Sample Codes	415
Sample Chart/Account Codes	415
Chart Codes with related Accounts/Object codes: BUDGETS	416
Sample Library (OLE) Organizations	418
Document Statuses	419
Purchase Order Statuses	419
Payment Request Statuses	419
Linked Resources	420

List of Tables

7.1. E-Resource Navigation Descriptions	191
-----------------------------------------------	-----

Introduction

This guide provides information about using Select and Acquire functions. The Select and Acquire module encompasses selection, purchasing, receiving, and payment for all library materials, both print and electronic. Full financial and budgeting structures, batch importing of vendor and bibliographic records, and tools supporting the lifecycle of electronic resources are incorporated in the module.

Note

To learn more about the Select and Acquire Module, see the *Select and Acquire Overview* on the [OLE Documentation Portal](#).

This guide is organized to follow the layout of the Select/Acquire tab followed by the Licensing tab. Please note there is a slight difference in Select/Acquire documentation. To follow the workflow, the documentation covers Order, Paying, Receiving and then returns to addressing each submenu in columns.

- Order provides access to the requisitions, purchase orders, and the order holding queue. Users initiate requisitions which become purchase orders sent to vendors.
- Paying provides access to invoices and credit memos. Users are able to invoice vendors or receive money back via the credit memo.
- Receiving provides access to monographic and serial receiving.
- Fund allows users to manage library funds.
- Acquisition provides access to search and edit payment requests, create general error corrections and disbursement vouchers, and search and edit E-Resources.
- Chart of Accounts contains the maintenance documents associated with the chart of accounts documents.
- Lookup and Maintenance provides access to the chart of accounts documents: accounts, subaccounts, organizations, objects and subobjects.
- Vendor provides access to vendor records as well as to search bibliographic records and acquisition documents.
- Vendor (2nd submenu) contains the maintenance documents associated with the vendor document.
- Import provides access to import batch marc and vendor files and view reports of these loads.
- Purchasing/Accounts Payable contains the maintenance documents associated with ordering, paying, receiving, and e-resources as well as general ledger entry and available balances lookups.

On the Licensing tab:

- Licensing provides access to the license request document.
- Licensing Admin contains the maintenance documents associated with license requests.
- Agreement Admin contains the maintenance documents associated with agreements.

These sections are divided into subsections covering individual functions. For each function, the applicable subsection presents a breadcrumb trail showing how to access the function and information on the layout and fields on the related screen(s). As appropriate, some subsections include business rules and routing information for e-docs and/or special instructions for performing activities.

Note

In order to work efficiently in the system's Select/Acquire and Licensing screens, you need to understand the basics of the user interface. For information and instructions on logging on and off, navigating, understanding the components of screens, and performing basic operations in the screens, see the [OLE Basic Functionality and Key Concepts](#).

This guide as well as guides to other OLE modules are available for download from the [OLE Documentation Portal](#).

Tip

Bookmark any page within OLE. This will allow you to easily navigate back to an interface or e-doc in one click, just log in.

Chapter 1. Accessing Purchasing and Accounts Payable Functions

The Kualo OLE Purchasing and Accounts Payable module includes several e-docs to help your institution manage its procurement processes. Kualo OLE users may initiate Requisition e-docs to request that orders be placed for goods or services. Fully approved Requisition e-docs are then processed by departmental staff and then become purchase orders (POs). Under certain conditions (specified by your institution's business rules in Kualo OLE), fully approved requisitions may become POs automatically without any additional processing.

Each PO is an official request for goods or services to a specified vendor for an agreed-upon cost. After goods are delivered or services rendered, Kualo OLE allows for the processing of vendor invoices through the Payment Request e-doc, which applies full or partial payment against a PO. Credits received from vendors may also be processed on a Credit Memo e-doc. Both payments and credit memos may then be applied to outstanding invoices when payment is due.

Purchasing and Accounts Payable e-docs are accessible from the Select/Acquire tab.

Chapter 2. Batch Processes

Users do not interact directly with OLE batch processes, but some users want to understand how these processes keep the data base up to date. For users who are interested, the following table summarizes the functions of the system's Purchasing/Accounts Payable batch processes. These processes, which are run according to a predetermined schedule, not only keep your data base up to date but, in some cases, generate new e-docs as needed to make certain types of adjustments.

Note

These batch processes continue to be reviewed into the 1.0 release.

Purchasing and Accounts Payable Batch Jobs

Job Name	Description
approveLineItemReceivingJob	If unordered items have been received and noted when doing line item receiving, Purchasing and Accounts Payable attempts to create a Purchase Order Amendment e-doc to adjust for the new items. If a purchase order cannot be amended for some reason (for example, if it is closed or has pending payment requests), this job rechecks each time it is run and creates the Purchase Order Amendment e-doc as soon as it is allowed to do so.
autoApprovePaymentRequestsJob	Automatically approves payment request documents with a current or past pay date.
autoClosePurchaseOrdersJob	Closes open purchase orders with no remaining encumbrance.
autoCloseRecurringOrdersJob	Looks at the end date on a recurring order (that is, a purchase order with a recurring payment type not equal to null). If this date is less than or equal to the date defined in the AUTO_CLOSE_RECURRING_PO_DATE parameter, it closes the purchase order and disencumbers any outstanding amounts.
electronicInvoiceExtractJob	Examines and validates invoices uploaded electronically by vendors. Creates Payment Request e-docs for valid invoices and creates Electronic Invoice Reject e-docs for invalid invoices.
faxPendingDocumentJob	Not yet supported by OLE; this job is a placeholder for a process used by Indiana University. (POs are queued electronically to be sent via fax, and this job runs every 15 minutes. If there is a problem with the fax device, the job fails. If the fax device is working normally, the POs are faxed.)
purchasingPreDisbursementExtractJob	Extracts all eligible and approved Payment Request and Credit Memos e-docs into the Pre-Disbursement Processor (PDP) for payment.
purchasingPreDisbursementImmediatesExtractJob	Extracts eligible and approved payment requests and credit memos flagged for immediate payment into the Pre-Disbursement Processor (PDP) for payment.
receivingPaymentRequestJob	If using receiving and if a payment request is entered that exceeds the open quantity on the purchase order, the payment request is held in "Waiting on Receiving" status. This job checks payment requests held in this status and releases them for normal routing when the purchase order has a sufficient open quantity.
approveLineItemReceivingJob	If unordered items are received when doing line item receiving, Purchasing and Accounts Payable attempts to create a Purchase Order Amendment e-doc to adjust for the new items. If the purchase order cannot be amended for some reason (for example, if it is closed or has pending payment requests), this job rechecks every time it is run and creates the Purchase Order Amendment e-doc as soon as it is allowed to do so.
autoApprovePaymentRequestsJob	Automatically approves payment request documents with a current or past pay date.
autoClosePurchaseOrdersJob	Closes open purchase orders with no remaining encumbrance.
autoCloseRecurringOrdersJob	Looks at the end date on a recurring order (that is, a purchase order with a recurring payment type not equal to null). If this date is less than or equal to the date defined in the AUTO_CLOSE_RECURRING_PO_DATE parameter, closes the Purchase Order and disencumbers any outstanding amounts.

Chapter 3. Ordering Materials: Standard Transactional E-Docs

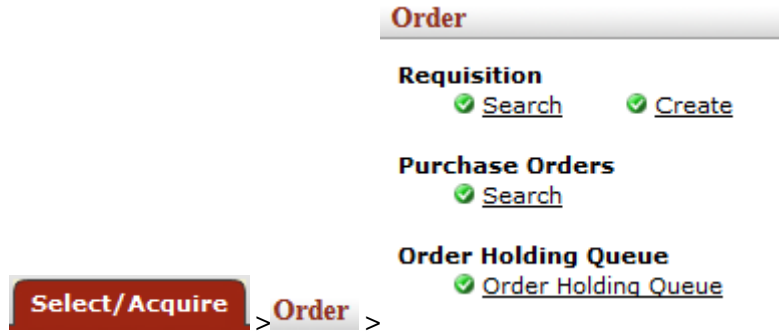

On the Select/Acquire tab, the Order submenu provides access to request and order library materials.

Requisition Search

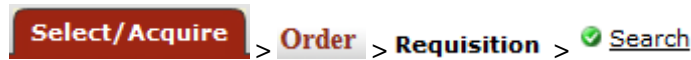

OLE offers a customized document search related to electronic requisitions. The search screen contains the standard search fields along with special fields that are unique to this type of e-doc.

Note

For information about performing a search for one or more requisitions, see [Performing Acquisition Searches](#) on the *OLE E-Doc Fundamentals* wiki page.

Note

For information about Document lookup fields that are specific to requisitions, see “Document Layout” under [Requisition](#).

Requisition

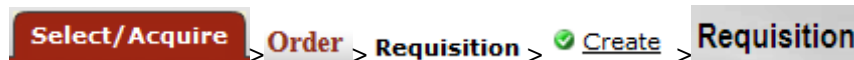

All orders begin in OLE as Requisitions. Requisitions or imported vendor files are processed into Approved Purchase Orders, or can be saved in support of ongoing Selection activities.

Getting Started

Log into OLE using one of the following IDs based on the level of permission you have selected to test drive.

Note

Note: As you open the application, OLE will automatically log in as ole-khuntley. When logging in as a new user, you do not need to first log out.

Anyone can create a requisition for routing. Users who can create a requisition, that, when all required fields are entered and business rules are satisfied, becomes an automatic/approved Purchase Order transmitted to Vendor:

Role	Login
Super user	ole-khuntley
Acquisitions-AQ2	ole-cphovis
Acquisitions-AQ3	ole-cstan
Acquisitions-AQ4	ole-earley
Acquisitions-AQ5	ole-ejacob

Note

Currently any authorized user of a Requisition e-Doc can process it into an Automated Purchase Order if all business rules and required fields are satisfied for *firm, fixed orders*. In future, the inherited routing rules and business rules will continue to be modified to prohibit Selection-staff from submitting an order (i.e., via Account codes).

The Requisition (REQS) document collects information about the desired items or services, possible vendors to fulfill the order, delivery instructions, contact information, and related accounting details. The approved Requisition document is used to generate the purchase order. Authorized users can process requisitions to Automated Purchase Orders for firm fixed orders

Requisition ?

Docur

Document Overview hide

Document Overview

* **Description:** Library Material_kyh_0819131337

Organization Document Number:

Financial Document Detail

* **Year:** 2014

Requisition Detail

* **Chart/Org:** UA / VPIT

Receiving Required:

Order Type: Firm, Fixed

Delivery show

Vendor show

Titles hide

Add Item ?

Bib Info:	<input type="radio"/> new bib	<input type="radio"/> existing bib		Location	
* No of Copies Ordered	<input type="text" value="1"/>	* No of Parts Ordered	<input type="text" value="1"/>	* List Price	<input type="text" value="0.00"/>
Receipt Status		No Of Copies Received		No of Parts Received	
Format	<input type="text"/>	Category	<input type="text"/>	Vendor Item Identifier	
* Unit Cost		Discount	<input type="text"/>	Discount Type	<input style="width: 20px;" type="text" value="%"/>

setup distribution remove accounts from all items expand all accounts collapse

Current Items

Additional Charges show

Totals

Payment Info show

Additional Institutional Info show

Account Summary show

View Related Documents show

View Payment History show

Notes and Attachments (0) show

Ad Hoc Recipients show

Route Log show

calculate submit save blanket approve close cancel

The Requisition document includes several unique tabs—**Delivery, Vendor, Titles, Payment Info, Additional Institution Info, Account Summary, View Related Documents, and View Payment History**.

Unlike a standard financial e-doc, there is no **Accounting Lines** tab, and the document header and the **Document Overview** tab are slightly different.

Requisition document tabs and purposes

Tab Name	Purpose
Document Overview	In addition to the standard document overview information (description, explanation, and organization document number), contains the fiscal year, line item receiving requirements, order types, , funding source, and the payment request positive approval required override flag, license requirement or review flag and status.
Delivery	Contains information about the final delivery and central receiving addresses.
Vendor	Suggests a vendor or a list of vendors who might provide the goods or services being requisitioned.
Titles	Identifies what is being ordered on this requisition and establishes an accounting distribution indicating how those items should be charged.
Payment Info	Indicates the type of payment schedule required and the duration of that schedule if recurring payments are required for the items on this requisition.
Additional Institutional Info	Collects information about the organization at your institution that has requested the goods or services for this requisition as well as the internal contact information.
Account Summary	Summarizes the accounting information for all line items on the requisition. The line items that make up the summary display here.
View Related Documents	Lists all documents related to a requisition, such as the purchase order, receiving documents, payments, credit memos.
View Payment History	Lists all payment requests and credit memos related to a requisition document.

Document Header

As in other OLE documents, the header section contains basic identification and status information about the document as well as who created it. The Requisition document has two additional fields in the document header that do not appear in other OLE documents: **REQ Nbr** and **REQ Status**.

Like the other fields in the document header, these fields are completed and updated automatically by Kualii OLE.

Doc Nbr:	4514	Status:	INITIATED
Initiator:	<u>ole-khuntley</u>	Created:	01:37 PM 08/19/2013
Requisition #:	Not Available	Requisition Doc Status:	In Process

Document header definition

Title	Description
Requisition #	An identifying number assigned to this requisition. This number, which may be used for queries specific to the Purchasing/AP module of OLE, differs from the Doc Nbr, which identifies the requisition as a unique document for general OLE and Workflow queries.
Requisition Status	A status that indicates where in the Purchasing/AP process a requisition is at any given time. This is similar to the status a document receives in



Workflow but is specific to the purchasing process. Examples of REQ Status might include 'Awaiting Fiscal Officer,' 'In Process,' and 'Closed'.

Note

For information about the standard e-doc header, see [Document Header](#) on the *OLE E-Docs fundamentals* wiki page.

Document Overview Tab

Unlike the **Document Overview** tab in other financial documents, a special **Fiscal Year** field is included in this tab on the Requisition document because, in some circumstances, users may be able to select from more than one fiscal year to which a Requisition should be applied. The tab also includes the **Requisition Detail** section, which identifies funding source for this requisition.

Document Overview		hide
Document Overview		Explanation:
* Description:	Library Material_kyh_0819131337	
Organization Document Number:		
Financial Document Detail		
* Year:	2014	
Requisition Detail		
* Chart/Org:	UA / VPIT 	Payment Request Positive
Receiving Required:	<input type="checkbox"/>	
Order Type:	Firm, Fixed 	

Document Overview tab definition

Title	Description
<i>Financial Document Detail</i>	
Year	Required. The default is the current fiscal year. This field is not editable until the 'ALLOW ENCUMBER NEXT YEAR DAYS' parameter has been met. Setting the year to the next fiscal year can affect the requisition in several ways. The requisition may not become an APO if the 'ALLOW APO NEXT FY DAYS' parameter has not been met, and the funds will not be encumbered until the next fiscal year once a PO is fully approved.
Total Amount	Display-only. Displays the total amount of the requisition after fees.
<i>Requisition Detail</i>	
Chart/Org	Required. Automatically completed based on the initiator's chart/org. This value may be changed manually via the lookup  . This value is also the chart/org that is used for the Content route level.
Receiving Required	Optional. Select the check box to ignore the receiving thresholds on the approved purchase order. If the field is checked, then a Line Item Receiving document must be processed with sufficient quantities received before a payment will route to the fiscal officer.
Order Type	Identifies the type of order, possible values could be one-time, standing, subscription. System default data value is "Firm, Fixed".
Funding Source	Required. Defaults to 'Institution Account'.
Payment Request Positive Approval Required	Optional. The 'DEFAULT POS APPRVL LMT' parameter determines the dollar limit where payment requests must receive positive approval from a fiscal officer. If this field is selected, positive approval on the payment request is required regardless of the total of the payment.

Delivery Tab

The **Delivery** tab contains information about where goods ordered on this requisition should be delivered. It also collects delivery contact information and any special delivery instructions. The system provides two ways for you to specify the delivery address: select the building from the **building** lookup or enter a different address by entering the address after selecting the **Other Building** option.

Note



When implementing OLE, libraries can update the Building maintenance e-Doc with their own building designations.

Delivery		<input type="button" value="hide"/>
Final Delivery		
* Delivery Campus:	BL	* Delivery To:
Building:	Poynter Center building not found <input type="button" value="set as default building"/>	Phone Number:
* Address 1:	618 E 3rd St	Email:
Address 2:	<input type="text"/>	Date Required:
* Room:	45	Date Required Reason:
* City:	Bloomington	Delivery Instructions:
State:	IN	
Postal Code:	47405-3602	
* Country:	UNITED STATES	
Receiving Address		
Receiving Address:	KUALI UNIVERSITY - PSYCHOLOGY DEPT. 3201 Sigmund Lane Kuali City, WY 83444 UNITED STATES	
Address To Vendor		
Shipping Address Presented to Vendor:		<input checked="" type="radio"/> Receiving Address <input type="radio"/> Final Delivery Address

Delivery tab definition

Title	Description
Delivery Campus	Required. Defaults to the appropriate campus for the user's chart/org. You may also search for another campus from the Delivery Campus lookup .
Building	Required. Search for the building to which goods should be delivered from the building lookup . Only buildings that correspond with the delivery campus will display. Selection of a building automatically completes the Address , City , State and Postal Code fields.
Address 1	Required; automatically populated from data for the Building value. May be entered manually if the user selects the Building Not Found button.
Address 2	Optional. Entered manually if an additional line of address is needed.
Room	Required. Enter the room number to which delivery should be made.
City	Required; automatically populated from data for the Building value. May be entered manually if the user selects the Building Not Found button.
State	Required; automatically populated from data for the Building value. May be entered manually if the user selects the Building Not Found button.

Ordering Materials: Standard Transactional E-Docs

Postal Code	Required; automatically populated from data for the Building value. May be entered manually if the user selects the Building Not Found button.
Country	Required; Automatically populated from data for the Building value. May be entered manually if the user selects the Building Not Found button.
Delivery To	Required. Defaults to the initiator's user name. You may enter another name or use the User lookup  to find it.
Phone Number	Optional. Automatically populated from the initiator's phone number but may be changed.
Email	Optional. Defaults to the initiator's user e-mail address but may be changed.
Date Required	Optional. Enter a date on which delivery is required or choose the date from the calendar  .
Date Required Reason	Optional. If a date required has been specified, select the appropriate date required reason from the list.
Delivery Instructions	Optional. Enter text describing any special delivery instructions for the item(s).
Receiving Address	If this field does not display, it is because the 'ENABLE RECEIVING ADDRESS INDICATOR' parameter is set to 'N'. If it does display, the default is determined by the receiving address that has been set up for the initiator's organization. May be changed by using the lookup  .
Shipping Address Presented to Vendor	Defaults to the receiving address. May be changed to the final delivery address. NOTE: If this field is read-only, it is because the 'ENABLE ADDRESS TO VENDOR SELECTION INDICATOR' parameter is set to 'No'.

Vendor Tab

The **Vendor** tab includes three sections: **Vendor Address**, **Vendor Info**, and **Additional Suggested Vendor Names**.

In order to generate a PO through the creation of a requisition it is important to search for and select vendors of the type "Purchase Order"

OLE has built in functionality to support both foreign and domestic vendors. Using a foreign vendor will require you to take the extra step of entering the **Foreign List Price** (illustrated in the instructions below).

Tip

To prepopulate vendor information, enter the **Vendor Alias Name** and click 

Foreign and Domestic Vendor Options

Vendor name	Vendor alias name	Foreign/domestic
Aleph-Bet Books	ABB	Domestic
D. K. Agencies (P) Ltd.	DKA	Foreign
Otto Harrassowitz	HARRAS	Foreign
YBP Library Services	YBP	Domestic

Ordering Materials: Standard
Transactional E-Docs

Vendor		▼ hide
Vendor Address		
Vendor Alias Name:	<input type="text"/> <input type="button" value="select vendor"/>	
Suggested Vendor:	<input type="text"/> <input type="button" value="clear vendor"/>	City: <input type="text"/>
Vendor #:		State: <input type="text"/>
Address 1:	<input type="text"/>	Province: <input type="text"/>
Address 2:	<input type="text"/>	Postal Code: <input type="text"/>
Attention:	<input type="text"/>	Country: <input type="text"/>
Vendor Info		
Acquisition Unit's Vendor account / Vendor Info Customer # :	<input type="text"/>	
Notes To Vendor:	<input type="text"/>	Payment Terms: <input type="text"/>
Contract Name:	<input type="text"/>	Shipping Title: <input type="text"/>
Phone Number:	<input type="text"/>	Shipping Payment Terms: <input type="text"/>
Fax Number:	<input type="text"/>	Contacts: <input type="text"/>
		Supplier Diversity: <input type="text"/>
Additional Suggested Vendor Names		
Vendor Name 1:	<input type="text"/>	
Vendor Name 2:	<input type="text"/>	
Vendor Name 3:	<input type="text"/>	
Vendor Name 4:	<input type="text"/>	
Vendor Name 5:	<input type="text"/>	

Vendor Address Section

Vendor Address section definition



Title	Description
Vendor Alias Name	If you know the vendor's alias, enter the code in the box and click <input type="button" value="select vendor"/> . This will prepopulate the Vendor address and information.
Suggested Vendor	Optional. Enter the name of a vendor that is able to fulfill this requisition or search for it from the Vendor lookup . Selecting a vendor from the table populates other fields in this tab based on the information already on file in OLE for this vendor. Alternately, you may select a contract (see below) and the vendor associated with that contract is automatically populated.
Vendor #	Display-only. Completed automatically when a suggested vendor is selected from the vendor table.
Address 1	Optional. Enter the first line of the address for the suggested vendor. If a vendor has been selected from the vendor table this field is automatically populated. If you want to select a different vendor address than the default, choose one of the addresses entered for this vendor from the Address lookup .
Address 2	Optional. Enter the second line of the address for the suggested vendor. If a vendor has been selected from the vendor table this field is automatically populated.
Attention	Optional. Enter the name of the person to whom the delivery is to be directed.
City	Optional. Enter the suggested vendor's city. If a vendor has been selected from the vendor table this field is automatically populated.
State	Optional. Enter the suggested vendor's state. If a vendor has been selected from the vendor table, this field is automatically populated.

Ordering Materials: Standard
Transactional E-Docs

Province	Optional. Enter the province if vendor is located outside of the United States.
Postal Code	Optional. Enter the selected vendor's postal code. If a vendor has been selected from the vendor table, this field is automatically populated.
Country	Optional. Enter the selected vendor's country. If a vendor has been selected from the vendor table, this field is automatically populated.

Vendor Info Section

Vendor Info section definition

Title	Description
Acquisition unit's vendor account/Vendor info customer #	Optional. Enter a customer number that identifies your institution or department for this vendor's reference Used for reporting and to separate out different library branches or locations' vendor acct information that all links to the same master vendor
Notes to Vendor	Optional. Include any text notes you want the vendor to see on the PO.
Contract Name	Optional. If a contract exists with the vendor for these goods or services, select one from the Contract lookup  . Selecting a contract also populates the vendor associated with that contract. Note The contracts are campus-specific. A requisition returns results only for the campus associated with the Chart/Org found on the Additional Institutional Info tab (see below). Selecting a contract affects the APO limit, depending on how the contract has been set up for the organization. The APO limit is usually increased when a contract is selected.
Phone Number	Optional. If a vendor has been selected from the Vendor table, this field may automatically be populated or the Phone Number lookup  will list all the Phone Numbers for this Vendor. Note The lookup is simply a convenience that allows you to view the phone number. It does not provide a return value link.
Fax Number	Optional. Enter the selected vendor's fax number. If a vendor has been selected from the vendor table, this field may automatically be populated.
Payment Terms	Display-only. If a vendor has been selected from the Vendor table or a contract, this field may be populated automatically.
Shipping Title	Display-only. If a vendor has been selected from the Vendor table or a contract, this field may be populated automatically.
Shipping Payment Terms	Display-only. If a vendor has been selected from the Vendor table or a contract, this field may be populated automatically.
Contacts	Optional. If a vendor has been selected from the Vendor table or a contract, the Contact lookup  will list all the contacts for the vendor. Note The lookup is simply a convenience that allows you to view the contacts list. It does not provide a return value link.
Supplier Diversity	Display-only. If a vendor has been selected from the Vendor table or a contract, this field may be populated automatically.

Additional Suggested Vendor Name Section

Additional Suggested Vendor Name section definition

Ordering Materials: Standard
Transactional E-Docs

Title	Description
Vendor Name (1-5)	Optional. Enter up to five additional suggested vendors that may be able to fulfill this requisition.

Title Tab

Expand the **Titles** tab of the requisition to fill in information about the library resource(s) being ordered. On this tab, multiple ordered resources can be added to the requisition by filling in all of the required fields and clicking the **add** button.

The **Titles** tab includes four sections: **Add Item**, **Current Items**, **Additional Charges**, and **Totals**.

Titles ▼ hide

Add Item ?

Bib Info:	<input type="radio"/> new bib	<input type="radio"/> existing bib		Location	<input type="text"/>		
* No of Copies Ordered	<input type="text" value="1"/>	* No of Parts Ordered	<input type="text" value="1"/>	* List Price	<input type="text" value="0.00"/>	Extended Cost	0.00
Receipt Status		No Of Copies Received		No of Parts Received		Item Price Source	Publish
Format	<input type="text"/>	Category	<input type="text"/>	Vendor Item Identifier		Requestor	<input type="text"/>
* Unit Cost		Discount	<input type="text"/>	Discount Type	<input type="text" value="%"/>		

Current Items

Additional Charges ▶ show

Totals

Grand Total:	<input type="text"/>
APO Limit:	10,00

Add Item and Current Items Sections

Add Item, Current Items section definition

Title	Description
Bib Info	Choose create new to link to the Bib Editor. Titles will appear in the after an item has been added.
Location	Select the location of the item being specified on this line from the dropdown list.
No of Copies Ordered	Required. Enter the quantity of the item in this field. Note If ordering more than on copy, you will need to fill out the copies tab.
No. of Parts Ordered	This is the number of individual pieces that must be accounted for upon payment/receipt of a requisitioned item.
List Price	Basic price of an item before any discounts are taken.
Extended Cost	Display-only. No of Copies ordered multiplied by the list price and minus any discount.
Public View	Optional. Indicates whether or not a bibliographic description shall be exposed to users prior to purchase/receipt. Default is Yes.
Currency Type	Display only if foreign vendor is chosen. Identifies the associated vendor's currency as identified on the vendor record that is identified in the Link to Vendor/Supplier.

Ordering Materials: Standard Transactional E-Docs

Exchange Rate	Display only if foreign vendor is chosen. Currency conversion rate populates from the Exchange rate and Currency Type maintenance tables. The rate will populate when user clicks action button "Calculate" on conversion tab. Optionally: when currency tab opens, currency rate may auto-populate. This may be updated up until the Requisition is approved. After that point, it may no longer be modified.
Foreign List Price	Basic foreign price of an item before any discounts are taken.
Receipt Status	Display only. Will reflect receipt status after receiving has occurred.
No Of Copies Received	Display only. The number of copies already received. This will populate as the document moves through the acquisition workflow.
No Of Parts Received	Display only. The number of parts already received. This will populate as the document moves through the acquisition workflow.
Item Price Source	Optional. Select the Price Source of the requested item from the dropdown list.
Request Source	Optional. Select the Request Source of the requested item from the dropdown list.
Format	Optional. Select the Format of the requested item from the dropdown list.
Category	Optional. Select a category for the item from the dropdown list.
Vendor Item Identifier	Display Only. Identifies a vendor item identifier if one has been provided by a vendor.
Requestor	Defaults to the selector's user name. If the Requestor is different than the selector, you may use the Requestor lookup  to find the requesting individual's name or create a new Requestor (this links to the OLE Patron database).
Route to Requestor	Optional. Yes/No checkbox to indicate whether a requestor should be notified when the item has been purchased. System default data value is "No".
Foreign Unit Cost	Display only if foreign vendor is chosen. Calculated foreign cost per unit for the item or service on this line. Calculation is the Foreign List Price less Foreign Discount amount.
Unit Cost	The cost per unit
Discount	Discount provided by the vendor/customer number/organization combination. Automatically populated from the Vendor customer number table based on the selected vendor and customer number. Can be modified for a specific title. If the vendor record has a Vendor currency noted other than the default system currency (aka US dollar), then the Vendor discount will populate the Foreign Discount field.
Discount Type	Choose # (for Amount) or % (for Percentage).
Foreign Discount	Foreign discount provided by the vendor/customer number/organization combination when the vendor record has a Currency Type different from the system default currency. Should be automatically populated from the Vendor customer number table based on the selected vendor and customer number. This data can be changed for the specific title. Must identify the type of discount (amount or %.) If the vendor record does not have a Currency Type noted other than the default system currency (aka US dollar), then the discount should populate the Discount field.
Foreign Discount Type	Choose # (for Amount) or % (for Percentage).
Actions	Add or delete lines as appropriate. After a line has been added, it is moved to the Current Items section, where the details may be viewed or modified.

Additional Charges Section

The Additional Charges tab allows lines for predetermined charges to be included on the payment request. This tab is divided into four charge lines, each representing a different type of charge, each with its own accounting lines, and a series of options through which the amounts added in this section can be prorated to the existing line items in the Current Items sub tab. The four Additional Charges lines are **Freight, Shipping and Handling, Minimum Order, and Miscellaneous or Overhead.**

Additional Charges section definition

Ordering Materials: Standard
Transactional E-Docs

Title	Description
Item Type	Display-only. Describes the type of miscellaneous item (freight, shipping and handling, etc.) being defined in this line.
Description	Required if the extended cost has been entered. Enter text describing the additional charges item line.
Extended Cost	Required. Enter the dollar amount for this item line.

Totals Section

Totals section definition

Title	Description
Grand Total	Display-only. This field displays a total of all item lines and miscellaneous item lines.
APO Limit	Display-only. This field displays the upper dollar limit for the creation of an automatic PO from this requisition. This dollar amount is based on a system default or, if a contract has been specified, on a contract-specific dollar amount.

Working in the Titles Tab

Note: If you are using a foreign vendor, you must also fill in the **Foreign List Price** pertaining to the item. OLE will then calculate for you the US Dollars Unit Cost.

Bibliographic Editor

The linked editor will populate the bibliographic information into this Requisition line item using the Title information in the linked/edited bib. If a minimum input is not filled in on the Editor, filling the "Bib Info" field on the requisition line item, then the requisition cannot be approved (later in the process). If you fail to fill in the required information in the linked editor, and attempt to approve this requisition, OLE will display the following error message: *Description in Item X is a required field.*

To add an Item to the Title tab

Users must complete the line item and linked bib in this sequential order. This will be fixed in future releases.

- **New line items:**

- First click  to launch editor in a new tab.

Home »
» Bibliographic Editor - MARC Format

Title / Author :

Collapse Navigation <<

Bibliographic Editor - MARC Format [1 message]

1 This page has 1 message

- Please enter details for new Bib record.

Staff Only:

Bibliographic Record Status: Created By : On: Updated By : On: Status

▼ Leader Structured Data Elements

RecStat: TypeRec:

Enclvl: DescCat:

Leader:

▼ Control Fields

001:

003:

005:

Show 006 Structured Data Elements

006:

Show 007 Structured Data Elements

007:

Show 008 Structured Data Elements

008:

▼ Data Fields

- Enter at minimum a 008 and a 245.
- Click .
- You will receive a confirmation message “Record successfully created”:
- Return to the original browser tab and add transactional data to the line (quantity, price, category etc.).

Note

The bibliographic information will not yet appear.

- Click  to save the line. This will update and link the bibliographic document and populate the **Bib Info** field.

Add Item ?						
Bib Info:	<input type="radio"/> new bib	<input type="radio"/> existing bib			Location	<input type="text"/>
* No of Copies Ordered	<input type="text" value="1"/>	* No of Parts Ordered	<input type="text" value="1"/>	* List Price	<input type="text" value="0.00"/>	Extend
Receipt Status		No Of Copies Received		No of Parts Received		Item Pri
Format	<input type="text"/>	Category	<input type="text"/>	Vendor Item Identifier		Requ
* Unit Cost		Discount	<input type="text"/>	Discount Type	<input style="width: 20px;" type="text" value="%"/>	

- **Editing existing line items:**
 - Click the **Edit** button to edit the linked bibliographic description of the existing line item. The editor will open in a new tab.
 - Modify the record as needed.
 - Click .
 - Return to the original tab.
 - You will not yet see your revised Bib Info from the updated bibliographic description, until you complete further actions on the overall purchasing e-Doc, such as **save**, **submit**, or **blanket approve**. If you are only saving your e-Doc, and wish to see Bib Info updates, you may need to **save** or **save and reload** the e-Doc AFTER making updates in the bibliographic description in order to update the Bib Info field with linked bibliographic changes - prior to **submit** or **blanket approve**.

Note

To learn more about the Editor, see the Editor section in the *Guide to Describe – DocStore and Editors*. This and other OLE user guides are available for download from the [OLE Documentation Portal](#).

Multiple Copies

If you enter a number greater than one in **No of Copies Ordered**, you will be required to enter location data. This section only appears when the field entry is greater than one

In the **Copies** section, click the  button.

Current Items						
Item 1						
1	Bib Info:	The Lorax				
	* No of Copies Ordered	<input type="text" value="2"/>	* No of Parts Ordered	<input type="text" value="1"/>	* List Price	<input type="text" value="30.00"/>
	Receipt Status		No Of Copies Received		No of Parts Received	
	Format	<input type="text" value="Book"/>	Category	<input type="text"/>	Vendor Item Identifier	
	Unit Cost	30.0000	Discount	<input type="text" value="0.00"/>	Discount Type	<input type="text" value="%"/>
<input type="button" value="show"/> Notes <input type="button" value="show"/> Accounting Lines <input type="button" value="show"/> Copies  <input type="button" value="show"/> Payment History						

The expanded section appears:

Copies			
Location Copies:	No. Of Copies:	No. Of Parts:	Starting Copy:
<input type="text"/>	<input type="text"/>		<input type="text" value="1"/>

Enter the copy information and click .

Copies section definition

Title	Description
Location Copies	Select the home location of the title being requested from the dropdown list.
No. of Copies	Enter the number of copies that will exist at the location selected.
No. of Parts	Display only. Once copies are added, this field is populated from the No of Parts Ordered .
Starting Copy	Enter the starting copy for the home location.
Caption	Optional. Enter a caption.
Volume Number	Enter the volume number for each item. You must enter the volume numbers sequentially for each value needed and separated only by commas (no spacing!). If there is only one volume, you must enter 1.

In the example below, there are two copies of *Describe Workbench Test* ordered containing two parts each. One copy will go to the location B-WELLS/BWE-RCSTACKS and one copy will go to B-ALF/BAL-STACKS.

Tip

Note the volume numbers are 1,2. Each number is separated by a comma but no spaces. OLE will also not allow non-numeric characters. If this format is not followed, you will receive an error.

Item 2						
2	Bib Info:	Describe Workbench Test KFX5ANBPD, OLE QA Smoketest KFX5ANBPD				
	* No of Copies Ordered	<input type="text" value="2"/>	* No of Parts Ordered	<input type="text" value="2"/>	* List Price	<input type="text" value="50.00"/>
	Receipt Status		No Of Copies Received		No of Parts Received	
	Format	<input type="text" value="Book"/>	Category	<input type="text"/>	Vendor Item Identifier	3067551
	Unit Cost	50.00	Discount	<input type="text" value="0.00"/>	Discount Type	<input type="text" value="%"/>
<input type="button" value="show"/>	Notes					
<input type="button" value="show"/>	Accounting Lines					
<input type="button" value="hide"/>	Copies					
	Location Copies:		No. Of Copies:		No. Of Parts:	Starting Copy:
	<input type="text"/>		<input type="text"/>			<input type="text" value="1"/>
	Location Copies:		No. Of Copies:		No. Of Parts:	Starting Copy:
	<input type="text"/>		<input type="text"/>			<input type="text" value="1"/>
	Copies 1					
	<input type="text" value="B-WELLS/BWE-RCSTACKS"/>		<input type="text" value="1.00"/>		<input type="text" value="2"/>	<input type="text" value="1"/>
	Copies 2					
	<input type="text" value="B-ALF/BAL-STACKS"/>		<input type="text" value="1.00"/>		<input type="text" value="2"/>	<input type="text" value="1"/>
<input type="button" value="show"/>	Payment History					

Importing Account Information

If you have a number of accounts to enter, you may create a .csv file containing the information and import it into the requisition. The template available:

- Purchase Requisition (REQS) account import, which uses the [Account_Import.xls](#) template

Note

For more information about the layout of these templates, see [Account_Import.xls](#) on the *OLE Data Import Templates* wiki page.

The procedure for accessing and using these templates is much the same as the procedure for using accounting line import templates.

Note

For information on using a template to import items or accounts, see [OLE Data Import Templates](#) wiki page.

Creating Accounting Distributions in the Titles Section

Accounting distributions for item lines may be created individually or a single accounting distribution may be copied to all line items on the requisition. A valid account string contains a chart, an account and an object code. The account must be active and the expiration date must not have been reached. The object code must be valid. Valid object codes are not only active codes in the object code table but are also not included in the 'OBJECT CONSOLIDATION' parameter. You must 'Add' at least one accounting line for

each item. If you do not, and attempt to approve this requisition, OLE will display the following error message: *Item 1 does not contain at least one account.* Adding at least one Accounting Line (with 100 in Percent) to each transactional line item will resolve this error.

To create accounting distributions for individual item lines, follow these steps.

2. Add the title to the requisition.
3. In the **Accounting Lines** section, click the  button.
4. Complete the accounting line and indicate a percent of this item line that should be charged to this accounting line.

Note

If there is only a single accounting line for this item the percent should be 100.

Note

You may add an entry to either the **Dollar \$** or the **Percent** fields. OLE will calculate the other after you click **add**. You cannot add entries to both fields.

5. Click  to add an accounting line.
6. If the items need to be distributed to more than one accounting line, repeat steps 3 and 4.

Note

All the accounting lines should total 100 percent when you have completed their accounting line distribution. If the total percent amount for all of the account lines does not equal 100%, the system will display an error message.

Note

If the account chosen has sufficient funds checking and the threshold is reached, you may be blocked from using the account or you may receive a warning (depending on the chosen notification on the account) when the document is saved and the Fiscal Officer will be notified when the document is submitted.

Note

This process may also be followed to add accounting distribution lines for items in the **Additional Charges** section. Open the **Accounting Lines** section for that miscellaneous line item and follow steps 4 and 5 above.

Line item accounting could create a lot of repetitive data entry. For example, if there are 100 line items but only one account/object code and one commodity code is being used, OLE allows you to load the information to all the line items rather than entering the information to each line item. The steps below describe how to distribute this information.

Note

Accounts are distributed only to the line items where there are no accounts listed. This process does not replace the accounts that have been set up for individual line items.

7. Click to add the item line to the requisition.
8. In the **Add Item** section, click the button.
The system opens a new **Accounting Lines** section.
9. Complete the accounting line and indicate the percent of this item line that is distributed to the items on this requisition.

Note

If there is only one accounting line for this item, the percent should be 100.

The system validates values as you enter them.

10. Click to add the accounting line.
11. If the items need to be distributed to more than one accounting line, repeat steps 3 and 4.

Note

All the accounting lines should total 100 percent when you have completed the distribution.

12. Click to apply this distribution to all item lines that do not already have an accounting distribution specified.
The system displays the top of the document along with a message indicating that the accounts were successfully distributed to all items.

Removing Accounts from all Item Lines

If line items have accounts set up and those accounts need to be modified, the individual accounting lines may be modified by following the steps for creating an accounting distribution for an individual item line as described above.

If you feel that it is more efficient to remove all the accounts, however, use the steps for creating an accounting distribution for multiple line items to recreate the accounting for the line items.

Follow these steps to remove all accounts.

13. Click .
14. Click in response to the question 'Are you sure you want to remove the accounts from ALL items?'
All the accounting lines are removed.

Expanding All Accounts

To expand the accounting lines for all the items in the Current Items section, click .

All the accounts are displayed in full detail.

Note

This is the equivalent of clicking the **Accounting Lines show** button for each item listed.

Collapsing All Accounts

To collapse the accounting lines for all the items in the **Current Items** section, click .

All the account displays are hidden.

Note

This is the equivalent of clicking the accounting lines **hide** button for each item listed.

Payment Info Tab

The **Payment Info** tab is used to indicate the type of payment schedule required and the duration of that schedule, if recurring payments are required for the items on this requisition.

The **Payment Info** tab includes two sections: **Payment Info** and **Billing Address**.



Payment Info Section

Payment Info section definition

Title	Description
Type of Recurring Payment	Optional. Select the proper recurring payment schedule from the list. Examples might include 'Fixed Schedule, Fixed Amount', 'Fixed Schedule, Variable Amount' and 'Variable Schedule, Variable Amount'.
Begin/End Date	Required if Type of Recurring Payment has been selected. Indicates the time period in which the requisition is active. Enter a date or select the date from the calendar  .

Billing Address Section



Billing Address section definition

Title	Description
Address	Display-only. Displays the address to which vendor invoices should be mailed. This address is based on the campus specified for delivery on the Delivery tab.

Additional Institutional Info Tab

The **Additional Institutional Info** tab collects information about the organization at your institution that is responsible for this requisition. It also collects information on the transmission method and collects contact information.

Additional Institutional Info tab definition

Title	Description
Method of PO Transmission	Required. From the list, select the PO transmission method that should be used to send the related PO to the vendor. Choices include 'Print' and 'No Print'.
Cost Source	Display-only. The cost source will always be 'estimate' unless the vendor was selected from the Contract lookup  . In that case the cost source associated with the contract is displayed here.
Contact Name	Optional. The name of the person to be contacted if there are questions about the requisition. Enter a name in the field or search for it from the User lookup  . Tip The contact name may be used if the requestor should not be contacted with questions.
Contact Phone	Optional. Enter the phone number of the person specified in the Contact Name field. (Formatted: xxx-xxx-xxxx)
Contact Email	Optional. Enter the email address of the person specified in the Contact Name field.
PO Total Cannot Exceed	Optional. This field indicates a total dollar amount that the associated PO should not exceed.
Requestor Name	Required. The name of the person requesting the good or services. The default is the initiator. This field may be changed by entering a new name or searching for it from the user lookup  .
Requestor Phone	Required. Enter the phone number of the person specified in the Requestor Name field. (Formatted: xxx-xxx-xxxx)
Requestor Email	Required. Enter the email address of the person specified in the Requestor Name field.
Reference (1-3)	Optional. Provide any type of additional reference information you want to include.

Working in the Additional Institutional Information Tab

The method of Purchase Order Transmission is set by default to the preferred method in the vendor record. If the method of Purchase Order transmission is selected as **No Print**, an EDI file representing the purchase order resulting from this requisition will be automatically created and transferred via FTP to a test server. The **Print** option should be selected if the vendor does not have access to FTP and needs a printed copy of the purchased order. Several of the fields of this tab are automatically populated with information.

Tip

OLE is not persisting a telephone number for ole-khuntley's record – you will need to input a phone number if using her login (formatted: xxx-xxx-xxxx).

Account Summary Tab

The **Account Summary** tab combines all the accounting information for the item(s) or service(s) on this requisition for easy reference.

Click [refresh account summary](#) to reload the page and view all the fiscal years, accounting lines and dollar amounts for this requisition.

Account Summary						
Account Summary 1						
Chart	Account Number	Sub-Account	Object	Sub-Object	Project	Org Ref Id
BL	1024700		5028			
Items of Account Summary 1						
Item		Description				
Shipping and Handling		shipping charges				85.00
Account Summary 2						
Chart	Account Number	Sub-Account	Object	Sub-Object	Project	Org Ref Id
BL	1024700		5028		3	
Items of Account Summary 2						
Item		Description				
Freight		flatbed for Globe				140.00
Account Summary 3						
Chart	Account Number	Sub-Account	Object	Sub-Object	Project	Org Ref Id
BL	1024700		7000			
Items of Account Summary 3						
Item		Description				
Item 1		Telescopes				20,400.00
Item 2		Control panel				43,589.00
Item 3		Rotating Globe				22,343.00

View Related Documents Tab

The **View Related Documents** tab collects information about the PO payment and credits related to this document. Click the document number to open the document in a new tab.

View Related Documents	
Related Documents	
Purchase Order - 1075	No Notes
Payment Request - 1062 (Purchase Order - 1075)	No Notes

View Payment History Tab

The **View Payment History** tab lists all payment request(s) and credit memo(s) issued against the related purchase orders.

View Payment History hide											
Payment History - Payment Requests											
PREQ #	Invoice #	PO #	PREQ Status	Hold	Req Canc	Vendor Name	Customer #	Amount	Pay Date	PDP Extract Date	Paid?
1042	12345	1009	AFOA	false	false	EASTMAN KODAK		2500.00	2007-10-09		
Payment History - Credit Memos											
CM #	Vendor CM #	PREQ #	PO #	Credit Memo Status	Hold	Vendor Name	Customer #	Amount	ADAP Date	PDP Extract Date	Paid?
1002	12345		1009	CMPT	false	EASTMAN KODAK		100.00	2007-09-29		

Payment Requests Section

Payment Requests section definition

Title	Description
PREQ #	Display-only. The payment request number.
Invoice #	Display-only. The invoice number.
PO#	Display-only. The purchase order number.
PREQ Status	Display-only. The payment request status.
Hold	Display-only. The value is 'true' if the payment request is on hold and 'false,' if the payment request is not on hold.
Req Canc	Display-only. The value is 'true' if the payment request has been canceled and 'false' if the payment request has not been canceled.
Vendor Name	Display-only. The vendor name.
Customer #	Display-only. The customer number.
Amount	Display-only. The payment request amount.
Pay Date	Display-only. The date to make payment on this payment request.
PDP Extract Date	Display-only. The date the payment request was requested for processing by the Pre-Disbursement Processor.
Paid?	Display-only. The value is 'true' if the payment has been disbursed and 'false' if the payment has not been disbursed.

Credit Memos Section

Credit Memos section definition

Title	Description
CM #	Display-only. The credit memo number defined in OLE.
Vendor CM #	Display-only. The credit memo number defined by the vendor.

Ordering Materials: Standard
Transactional E-Docs

PREQ #	Display-only. The payment request number.
PO #	Display-only. The purchase order number.
Credit Memo Status	Display-only. The credit memo status.
Hold	Display-only. The value is 'true' if the credit memo is on hold and 'false' if it is not on hold.
Vendor Name	Display-only. The vendor name.
Customer #	Display-only. The customer number.
Amount	Display-only. The credit memo amount.
APAD Date	Display-only. The accounts payable approved date (the date the Accounts Payable Review group approved the credit memo).
PDP Extract Date	Display-only. The date the credit memo was requested for processing by the Pre-Disbursement Processor.
Paid?	Display-only. The value is 'true' if a payment has been disbursed to which this credit memo was applied and 'false' if it has not yet been included in a payment.

Note

For information about **Notes and Attachments**, **Ad Hoc Recipients**, and **Route Log** tabs, see [Standard Tabs](#) on the *OLE E-Doc Fundamentals* wiki page.

Process Overview

Manually Creating a Requisition

Open a **Requisition** document from the **Main Menu**. By default, the **Document Overview** tab will be open and several of the form fields will be pre-populated with data such as Description and Year.

Tip

Input a familiar “description” for the document. This input can be used in future search.

In the future, if the **Receiving Required** field is selected, payment cannot be requested in OLE until the receiving process is complete. However even if you keep **Receiving Required** un-checked, a Receiving Threshold business rule will offer a secondary business check (i.e., maximum allowable without physical receiving).

Tip

Remember that all required fields are noted with (*) and must be completed to Submit or Blanket Approve (but not Save).

In the Accounting Line section of the requisition form, the required fields are **Chart**, **Account Number** and **Object**.

Suggested Data Values to use:

Chart: **BL**

Account Number: **2947500**

Object Code: **7119**

A full set of valid demo values are available in the [Chart Code/Account Appendix](#)

When these values are entered into the fields, OLE will look up and display the text value associated with each of the codes.

Warning

Caution: It is important to select the **Chart** code. The account number and object code look-up will not work properly if the Chart code has not been selected.

Before the requisition form can be submitted, the  button, which appears at the bottom of the screen, must be clicked.

- The **submit** button sends the form to the next person in the workflow chain.
- The **save** button allows you to save the requisition to come back to it later.
- The **blanket approve** button fully approves this requisition without the need for any other approvals. The Blanket Approve button is permissions based - not all sample logins will have this option.
- The **close** button closes this requisition. Clicking the **close** button will cause a prompt asking you if you would like to save the document before it is closed.
- The **cancel** will completely delete the requisition changes, but will show a warning message first.

If during your creation of a Requisition in OLE you would like to generate a purchase order without any further approval being required, select  for your requisition. As a result, OLE will automatically create the purchase order. After clicking the **blanket approve** button, you will be returned to the Quali OLE Main Menu.

Creating a Requisition Using the OLE Web Form

Note

While the PreOrder Service is available, a bug has been reported that the error "ERROR: Could not send Message" appears when users submit and requisitions are not created. This is due to be corrected for the 1.0 release.

Getting Started

OLE 1.0 provides a demo web form which is meant to simulate a request that would originate from an implementing Library Website. Because the OLE web form was developed for demo purposes only, the screen does not contain any validations (although it may require the input of a Requestor). The menu item for the web form is labeled **PreOrder Service** and can be found on the **Administration** tab, in the Testing Section under **Testing**:

Using the Web Form to Generate a Requisition

After clicking the **PreOrder Service** link (as described above), the web form appears. The web form allows you to make a request via Citation, Open URL or based upon item details entered in the web form depending on the option you select within the form:

The screenshot shows a web form with a yellow header containing 'action list' and 'doc search' buttons. Below the header, there are three radio buttons: 'Citation' (selected), 'Web Form', and 'Open URL'. The 'Citation' option is circled in blue. Below the radio buttons are four input fields: 'Citation String' (a large text area), 'Requestor Type' (a dropdown menu with 'PATRON' selected), 'Requestor Notes' (a large text area), and 'Requestor Id' (a single-line text input). A 'Submit' button is located at the bottom left of the form.

Note

OLE 1.0 offers simple web form processing and simple citation parsing based on the citation example below, or other simple user/web form inputs. The open-source tools being used for more complex citations and URL resolver are still being debugged, and users may see errors for this functionality still in development.

To submit the web form via Citation, select the **Citation** radio button and enter your citation into the **Citation String** field and enter a patron ID in the **Requestor Id** field. In addition, optionally enter notes in the **Requestor Notes** field. Then, click the **Submit** button.

The result will be a confirmation page providing you with a document ID number:

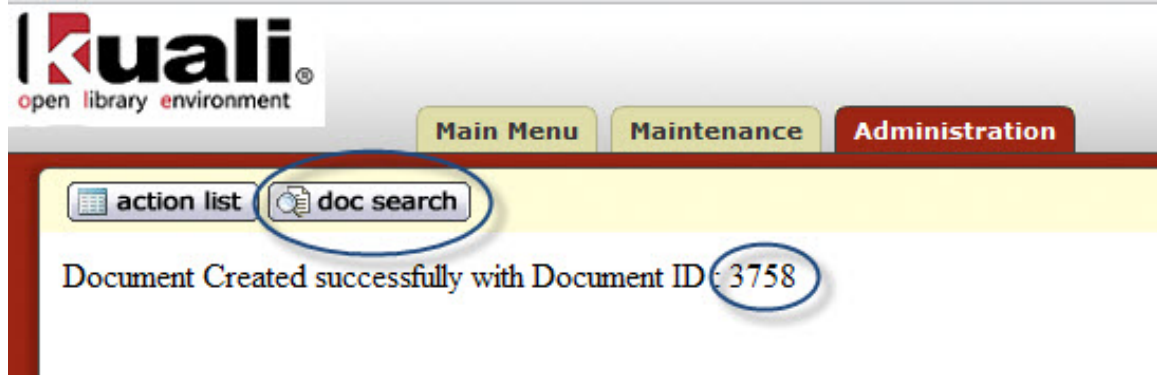

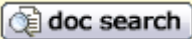
This Document ID can then be used to view the requisition that was created. To view the requisition, click the current default  button.

From the **Document** lookup page you can search for the requisition using the **Document ID**.

Note

For more information, see [Searching OLE](#) on the *OLE E-Doc Fundamentals* wiki page.

To view the requisition, click the **Document/ Notification Id** URL.

Note

The current default search does not allow you to search by bibliographic information. However, if you select the **Acquisitions Search** from the **Main Menu**, you can use bibliographic search terms.

Note

See the [Custom Document Searches](#) section for more information about the Acquisition Search.

action list doc search

Document Lookup ?

Type:	<input type="text"/>
Initiator:	<input type="text"/>
Document/Notification Id:	<input type="text"/>
Date Created From:	11/04/201
Date Created To:	<input type="text"/>
Name this search (optional):	<input type="text"/>

search clear ca

clear

1 items found. Please refine your search criteria to narrow down your search.
One item retrieved.

Document/Notification Id	Type	Title
3758	Requisition	Requisition - WebformRequest_jd_11040245

Export options: [CSV](#) | [spreadsheet](#) | [XML](#)

This requisition is considered to be in an 'open' status requiring staff input and edits. At this stage staff members may conduct additional research to determine if they want to order the item.

The requisition will contain a default description – “WebformRequest_fl_MMDDHHMM”, where "fl" are the first and last initials of the requestor name entered on the web form, MM and DD are the Month and Day, and HH and MM are the hour and minute of the requisition's creation. The bib info of the library resource and requestor name will be a part of the requisition. To see additional details about the

Ordering Materials: Standard
Transactional E-Docs

requestor entered through the web form click the lookup icon  next to the name of the requestor:

Document Overview hide

Document Overview

* Description: WebformRequest_kh_05270826

Organization Document Number:

Explanation:

Financial Document Detail

* Year: 2013

Requisition Detail

* Chart/Org: UA / VPIT 

Receiving Required:

Order Type: Firm, Fixed

* Funding Source: INS

Payment Request Positive Approval Required:

Licensing Requirement/Review:

Licensing Requirement/Review Status:

Delivery show

Vendor show

Titles hide

Add Item 

Bib Info:	<input type="text"/>					Item Type	<input type="text"/>
* No of Copies Ordered	<input type="text" value="1"/>	* No of Parts Ordered	<input type="text" value="1"/>	* List Price	<input type="text" value="0.00"/>	Extended Cost	<input type="text" value="0.00"/>
Receipt Status		No Of Copies Received	<input type="text" value="0"/>	No of Parts Received	<input type="text" value="0"/>	Item Price Source	<input type="text" value="Publisher"/>
Format	<input type="text"/>	Category	<input type="text"/>	Vendor Item Identifier		Requestor	HUNTLEY, KEISHA Y 
* Unit Cost		Discount	<input type="text" value="0.00"/>	Discount Type	<input type="text" value="%"/>	<input type="button" value="add"/>	

Current Items

Item 1

Bib Info:	Mudlumps at the mouth of South Pass, Mississippi River; sedimentology, paleontology, structure, origin, and relation to deltaic processes.					Item Type	<input type="text"/>
* No of Copies Ordered	<input type="text" value="1"/>	* No of Parts Ordered	<input type="text" value="1"/>	* List Price	<input type="text" value="0.00"/>	Extended Cost	<input type="text" value="0.00"/>
Receipt Status		No Of Copies Received	<input type="text" value="0"/>	No of Parts Received	<input type="text" value="0"/>	Item Price Source	<input type="text" value="Publisher"/>
Format	<input type="text"/>	Category	<input type="text"/>	Vendor Item Identifier		Requestor	HUNTLEY, KEISHA Y 
Unit Cost	<input type="text" value="0.0000"/>	Discount	<input type="text" value="0.00"/>	Discount Type	<input type="text" value="%"/>	<input type="button" value="delete"/>	

This requisition is partially filled in based on the data entered in the Web form. However, all required fields must be filled in (as described in the Manually Creating a Requisition section above) before the requisition can be approved.

Tip

Citation Sample Data:

Morgan, James P., James M. Coleman, and Sherwood M. Gagliano. 1963. Mudlumps at the mouth of South Pass, Mississippi River; sedimentology, paleontology, structure, origin, and relation to deltaic processes. Baton Rouge: Louisiana State University Press.

Business Rules

- In addition to the other required data (such as description, delivery information, and additional details), the requisition must have at least one item on the item tab in order to be submitted to workflow for routing.
- If the chart/org on the requisition does not have a content routing rule set up, the requisition routes back to the initiator of the requisition if there are no accounts entered. Otherwise, accounting lines are not required.
- Account distributions must exist for all item lines on the document before it may leave the content routing stage.

The Automatic Purchase Order (APO) is automatically generated when a requisition e-Doc is fully approved and all the APO rules are met. APO rules are:

- requisition total is less than the APO limit for the departmental organization (value set by Purchasing)
- requisition total is greater than 0
- there are no restricted items
- the vendor has been selected from the vendor lookup
- the vendor is not a restricted vendor
- the requisition is not a recurring payment type of request
- the departmental organization has not set an 'Purchase Order Total Cannot Exceed' amount
- the requisition has not added alternate vendor names
- the funds will be encumbered in the current fiscal year
- the requisition does not contain a trade-in and discount line item
- the requisition does not have a capital asset object code on any line items

An APO e-Doc can only be created under certain conditions, as specified in the business rules set up by the institution.

Ordering Materials: Standard
Transactional E-Docs

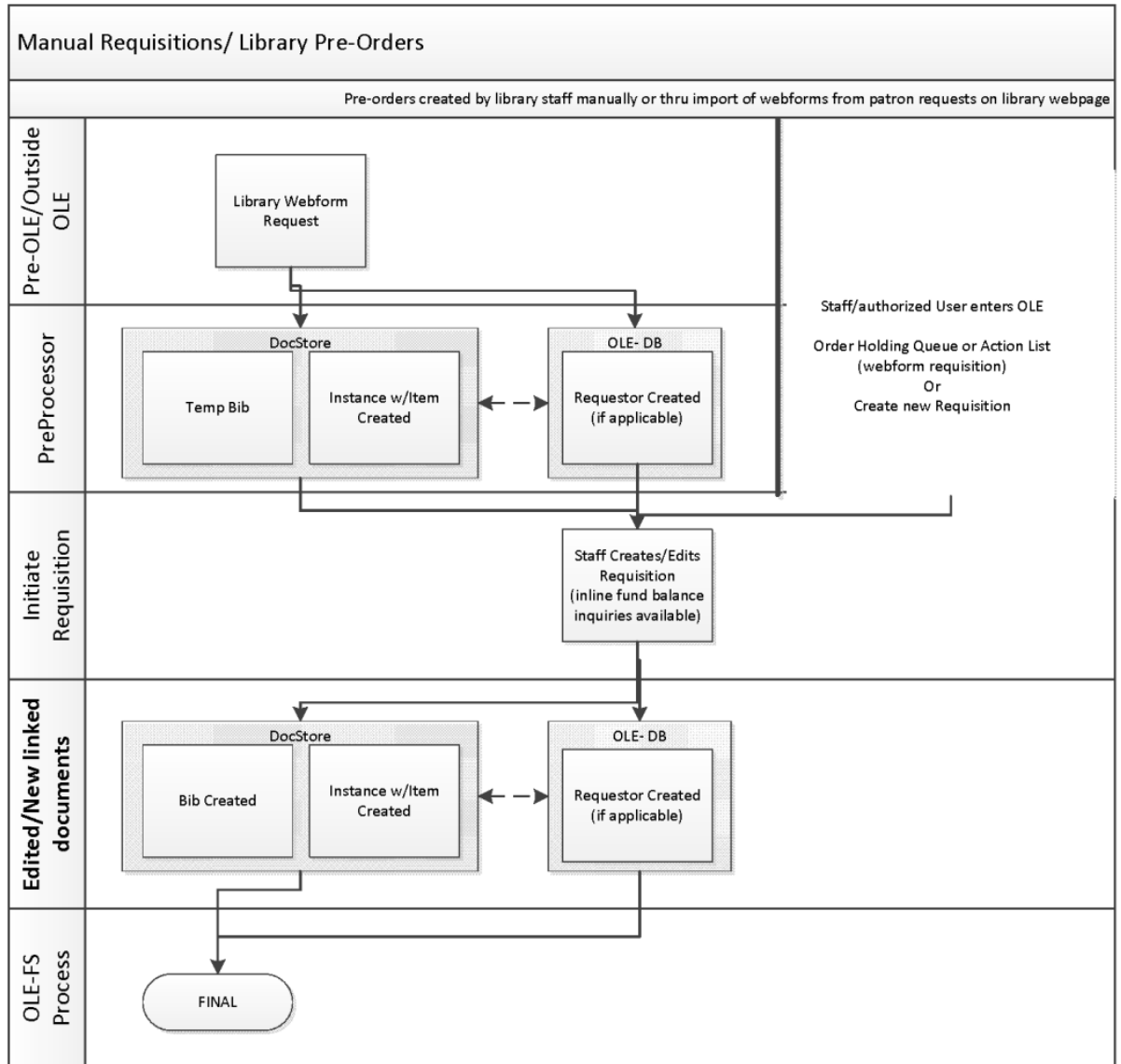

Routing

The requisition document routing includes the following special condition routing in addition to the regular account review and organization review hierarchy:

- Content routing* This type of routing allows the initiator of a requisition to route an incomplete document and have it completed by another OLE user. Content routing is optional and rules are created based on the Chart and Organization values in the requisition's **Requisition Detail** section of the **Document Overview** tab. A user who receives a document via content routing has a request type of 'Complete' for the document in his or her action list. This user may open the document, complete it and send it into normal routing. Content routing is most commonly used for the completion of accounting information.
- Sub-account review* The requisition allows for approvers to be defined at the sub-account level. If the requisition uses a sub-account on its accounting lines, Workflow checks to see whether there is a specified routing rule for this sub-account. Users can only approve/disapprove the document at this level. Approvers cannot change content.

- *Fiscal officer routing*: Approvers can modify and/or add accounting lines for accounts that they own; the only other content that can be modified at this level is the Org Document Number field.
- *Base/org review routing*: Optional route level to work groups for the accounts set-up on the document based on the requisition amount total and charts/orgs in use.
- *Separation of duties*: This rule routes a requisition to a defined central approver if the amount of the document exceeds an institutionally defined threshold and there have been no approvers other than the document initiator. This routing ensures that requisitions above a specified dollar amount are approved by at least two users. Approvers can only approve/disapprove. Approvers cannot change requisition content.

Post-Processing

- If certain criteria are met (low dollar limit, vendor has been selected, etc.), the requisition will be fully approved and will generate an automatic purchase order (APO) and the PO will begin routing.
- Based on the rules described in the Additional Workflow Details (above), an approval of a requisition can generate an Automatic Purchase Order (if vendor information was entered into the requisition). To search for an Automatic Purchase Order click the **Search** link under the **Purchase Orders** section of the **Select/Acquire** tab.

From the purchase order screen, you can send notifications using the **send ad hoc request** button. You can also **void order**, **amend** the order, indicate **payment hold** or proceed to directly to the **receiving** step by using the buttons at the bottom of the form:

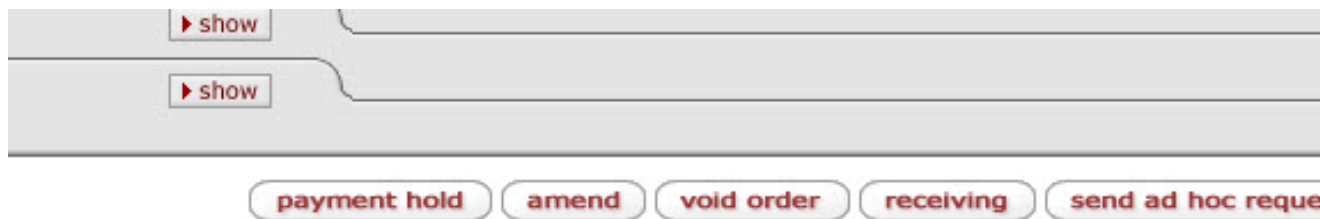

Note

For more information on searching, see [Searching OLE](#) on the *OLE E-Doc Fundamentals* wiki page.

For information about the account review and organization review see [Route Levels and Workflow Routing](#) on the *OLE Workflow Overview and Key Concepts* wiki page.

Requisitions Exception Routing and Requisition Searches

If you submitted a requisition but the submission did not create a Purchase Order as expected, it may not have met all the rules for APO. To find the Requisition and correct the error, conduct a **Requisitions Search**.

Note

For more information about Requisition searches, see [Custom Document Searches](#).

Purchase Order Search

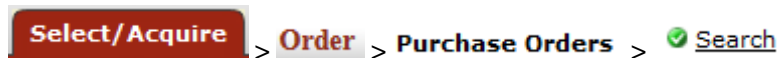

OLE offers a customized document search related to purchase orders. The search screen contains the standard search fields along with special fields that are unique to this type of e-doc.

Note

For information about performing a search for one or more purchase orders, see [Performing Acquisition Searches](#) on the *OLE E-Doc Fundamentals* wiki page.

For information about Document lookup fields that are specific to POs, see “Document Layout” under [Purchase Order](#).

Purchase Order

After manually creating a requisition, the next step is to turn it into a purchase order (PO). This finalizes the purchasing decision, and transmits the request to the vendor, through whatever transmission method is defined for that vendor.

The approved Purchase Order (PO) document serves two purposes. Externally it is a legal contract with a vendor to deliver goods or services. Internally it provides the mechanism to generate documents for payments and receipt of goods. It differs from most other OLE documents in three ways:

The PO is *not* generated by initiating a blank document that is then completed by the initiator. Instead, purchase orders are currently created in one of several ways:

- vendor import;
- from a Requisition that met the APO rules (automatic purchase order)- after submitting from Requisition or Order (pre order) Holding Queue; or,
- upon "exceptions" during submission of a Requisition via Acquisitions staff.

When creating the new PO, the system automatically populates it with information from the related requisition.

The document can be worked on by any purchasing staff member. An 'in process' PO can be edited by any staff member who is a member of the Purchasing Processor, OLE-Acquisitions, or OLE_Selectors roles.

A purchase order can be amended after it is approved. No other OLE document behaves in the manner. Many purchasing organizations refer to this amended PO as a 'change order'.

Note

For more information about modifying an existing PO, see [Performing Other Activities on a PO](#).

PO documents may be retrieved via document search. From this point, the purchasing staff may finalize the details of a purchase order and transmit it via fax, electronically through EDI, or print it for mailing to the vendor.

Note

You may use the regular **doc search** button to retrieve a PO, but this form of search does not include PO-specific search criteria.

All the same fields from the Requisition will transfer over to the open Purchase Order, as well as additional tabs. Be sure to review and fill in all required fields – a Requisition that failed to become an Automatic Purchase Order is likely to be missing required information such as Vendor, accounting lines, prices.

Note

For more information about a PO search, see [Custom Document Searches](#).

Getting Started

Log into OLE using one of the following test IDs based on the level of permission you have selected to test.

Below are users who can:

- Create a requisition that, when all required fields are entered and business rules are satisfied, becomes an automatic/approved Purchase Order transmitted to Vendor
- Complete data entry and approval on a submitted Requisition that did not create a Purchase Order

Role	Login
Super user	ole-khuntley
Acquisitions staff	ole-fermat
OLE_Selector	ole-cstan

Note

See a complete list of all available users and their permission in the section on [switching users](#) on the *Navigating Through OLE* wiki page.

Document Layout

The PO document contains several unique tabs or unique sections in tabs that appear on all OLE documents : **Document Overview** (contains unique sections), **Delivery, Vendor, Stipulations, Titles, Payment Info, Additional Institutional Info, Quote, Account Summary, View Related Documents,** and **View Payment History**. While some of these tabs may appear in other financial documents, the tabs in a PO document may contain additional information.

Note

For information about the standard tabs such as **Document Overview, General Ledger Pending Entries, Notes and Attachments, Ad Hoc Recipients, Route Log, Capital Asset,** and **Accounting Lines** tabs, see [Standard Tabs](#) on the *OLE E-Doc Fundamentals* wiki page.

Ordering Materials: Standard
Transactional E-Docs

Purchase Order ?

Document Overview ▼ hide

Document Overview

* **Description:** Library Material_kyh_0819131455

Organization Document Number:

Financial Document Detail

* **Year:** 2014

Purchase Order Detail

* Chart/Org:	UA / VPIT	* Funding Source:	
Receiving Required:	No	Payment Request Positive Approval Required:	
Assigned To User:		Previous Purchase Order Confirmed Indicator:	
Order Type:	Firm, Fixed	Requisition Source:	

Delivery ▶ show

Vendor ▶ show

Stipulations ▶ show

Titles ▼ hide

Current Items

Item 1

	Bib Info:	RichTest				Location:	
1	* No of Copies Ordered	1	* No of Parts Ordered	1	* List Price	50.00	Extended Cost
	Receipt Status		No Of Copies Received		No Of Parts Received		Item Price Source
	Format		Category		Vendor Item Identifier		Requestor
	Unit Cost	50.00	Discount	0.00	Discount Type	%	

▶ show **Notes**

▶ show **Accounting Lines**

▶ show **Payment History**

Additional Charges ▶ show

Totals

Grand Total

Internal Purchasing

Payment Info ▶ show

Additional Institutional Info ▶ show

Quote ▶ show

Account Summary ▶ show

View Related Documents ▶ show

View Payment History ▶ show

General Ledger Pending Entries ▶ show

Notes and Attachments (0) ▶ show

Ad Hoc Recipients ▶ show

Route Log ▶ show

Ordering Materials: Standard
Transactional E-Docs

Purchase Order document tabs and purposes

Tab Name	Purpose
Document Overview	In addition to the standard document overview information (description, explanation, and organization document number), contains the fiscal year, line item receiving requirements, order type, funding source, previous purchase order number, the source of the requisition, a way to alter the status of the PO when waiting on information from a vendor or the department, and license requirement information.
Delivery	Contains information about the final delivery and central receiving addresses.
Vendor	Contains information about the vendor who has been selected to provide the goods or services and the reason the vendor was selected.
Stipulations	Allows for the entry of stipulations that the vendor filling this PO must follow. May also be used for any additional contractual information that should be added to the PO.
Titles	Identifies what is being ordered on this PO and establishes an accounting distribution indicating how these items should be charged.
Payment Info	Indicates the type of payment schedule required and the duration of that schedule if recurring payments are required for the items on this PO
Additional Institutional Info	Collects information about the organization at your institution that has requested the goods or services for this PO as well as the transmission method and internal contact information.
Quote	If a quote is initiated in the purchasing process this tab will contain the list of vendors who were invited to participate in the quote process. Each vendor's response, and ranking, along with the name of the vendor awarded the order, is displayed here.
Account Summary	Summarizes the accounting information for all the line items on this PO. The line items that make up the summary display here.
View Related Documents	Lists all documents related to this PO such as the requisition, receiving documents, payments, credit memos. Also all the various PO documents that are created from the PO when the PO is amended, closed, or open.
View Payment History	Lists all the payment requests and credit memos related to this PO document.
General Ledger Pending Entries	Generates a display-only view of the encumbrances that have not yet posted the G/L. This tab may be empty if there are no pending entries.

Document Header

As in other OLE documents, the header section contains basic identification and status information about the PO document as well as who created it. However, the PO document has two additional fields in the document header that do not appear in other OLE documents.

Doc Nbr:	4584	Status:	FINAL
Initiator:	ole	Created:	03:35 PM 08/19/2013
Purchase Order #:	1058	Purchase Order Doc Status:	Open

These additional fields are defined below.

Document Header definition for a Purchase Order document

Title	Description
Purchase Order #	An identifying number assigned to this PO. The PO number may be used for queries specific to the Purchasing/AP module of the OLE. This number differs from the Doc Nbr entry, which identifies the PO as a unique document for general OLE and Workflow queries.
Purchase Order Status	A status that indicates where the PO is in the Purchasing/AP process. This indicator is similar to the status a document receives in Workflow, but it is specific to the purchasing process. Examples of PO status include 'In Process,' 'Awaiting Purchasing Approval,' 'Out for Quote,' and 'Closed'.

Document Overview Tab

The **Document Overview** tab on the PO contains three sections: **Document Overview**, **Financial Document Detail**, and **Purchase Order Detail**.

Document Overview		▼ hide
Document Overview		
		* Description: Library Material_kyh_0819131455
		Organization Document Number:
Financial Document Detail		
		* Year: 2014
Purchase Order Detail		
* Chart/Org:	UA / VPIT	* F
Receiving Required:	No	Payment Request Positive App
		Previous Pur
Assigned To User:		Purchase Order Confi
		Req
Order Type:	Firm, Fixed	

Note

The following section definitions contain only fields that are unique to the PO document. For more information about the standard **Document Overview** tab, see [Standard Tabs](#) on the *OLE E-Doc Fundamentals* wiki page.

Financial Document Detail Section

Financial Document Detail	
	* Year: 2014

Document Overview section definition

Title	Description
Year	Required. The default is the current fiscal year and this field isn't editable until the 'ALLOW ENCUMBER NEXT YEAR DAYS' parameter has been met. If the FY is set to the future then funds will not be encumbered until that next fiscal year. Note This field automatically defaults to the current fiscal year.
Total Amount	Display-only. The total PO amount.

Purchase Order Detail Section

Purchase Order Detail	
* Chart/Org:	UA / VPIT
Receiving Required:	No
Assigned To User:	
Order Type:	Firm, Fixed

Ordering Materials: Standard
Transactional E-Docs

Purchase Order Detail section definition

Title	Description
Chart/Org	Required. Automatically completed based on the requisition's chart/organization. May be changed manually by clicking the lookup 
Receiving Required	Optional. This flag can be set by a Purchasing Processor while a PO is 'in process'. If the field is checked manually, the system will not use receiving thresholds to determine whether receiving is required. If the field is checked, a line item Receiving document must be processed with sufficient quantities received before a payment will route to the fiscal officer. After the PO is approved, this value cannot be changed.
Assigned to User	Allows a user to take ownership of an in-process document. Users can then easily find documents they are working on.
Order Type	Identifies the type of order, possible values could be one-time, standing, subscription. System default data value is "Firm, Fixed".
Funding Source	Display-only. The funding source for the PO; derived from the requisition.
Payment Request Positive Approval Required	Optional. The 'DEFAULT POS APPRVL LMT' parameter determines the dollar limit at which payment requests must receive positive approval from a fiscal officer. If selected, this field overrides the parameter and requires positive approval on the payment request regardless of the total of the payment.
Previous Purchase Order #	Optional. Identifies the previous PO number associated with this purchase order. This field is typically used to identify the converted PO number from a legacy purchasing system.
Purchase Order Confirmed Indicator	Optional. Select this box to indicate that this PO is being created after the purchase has been made. This field may be used to track instances in which users did not properly create a requisition before making a purchase. In this case, the PO is being processed only to enter the transaction into OLE.
Requisition Source	Display only. Indicates whether the requisition that created this PO was input directly or created in some other way such as B2B.



Delivery Tab

The **Delivery** tab contains information about where goods ordered on this PO should be delivered. It also collects delivery contact information and any special delivery instructions. The address that is transmitted to the vendor (final delivery vs. receiving address) depends on the radio button that is selected in the **Address to Vendor** section.



Delivery	
hide	
Final Delivery	
* Delivery Campus:	BL - BLOOMINGTON
Building:	Wells Library
* Address 1:	1320 E 10th St
Address 2:	
* Room:	100
* City:	Bloomington
State:	IN
Postal Code:	47405-3907
* Country:	United States
Receiving Address	
Address To Vendor	

The following table explains the fields on this tab. With the exception of the last two fields listed, all fields pertain to the **Final Delivery** section. When the PO is initiated, all information in the tab is populated from the information in the same tab of the requisition. The fields described below apply only if the default information from the requisition needs to be updated by Purchasing.

Delivery tab definition

Title	Description
Delivery Campus	Required. Defaults to the delivery campus that was selected on the requisition. Search for another campus by clicking the lookup  button.
Building	Required. Search for the building to which goods should be delivered from the building lookup  . Only buildings that correspond with the delivery campus will be displayed. Selection of a building automatically completes the Address , City , State and Postal Code fields.
Address 1	Required (display-only); automatically populated from data in Building . May be entered manually if you clicked the building not found button.
Address 2	Optional; Entered manually if an additional line of address is needed.
Room	Required. Enter the room number to which delivery should be made.
City	Display-only. Automatically populated from data in Building . May be entered manually if you clicked the building not found button.
State	Display-only. Automatically populated from data in Building . May be entered manually you clicked the building not found button.
Postal Code	Display-only. Automatically populated from data in Building . May be entered manually if you clicked the building not found button.
Country	Display-only. Automatically populated from data in Building . May be entered manually you clicked the building not found button.
Delivery To	Required. This entry defaults to the user's name on the requisition. The User lookup  can be used if the name needs to be changed.
Phone Number	Optional. This entry defaults to the phone number from the requisition. (Formatted: xxx-xxx-xxxx)
Email	Optional. This entry defaults to the email address from the requisition.

Ordering Materials: Standard
Transactional E-Docs

Date Required	Optional. Defaults to the date required from the requisition. Change or enter a date on which delivery is required or use the date from the calendar 
Date Required Reason	Optional. If a date required has been specified, select the appropriate date required reason from the list.
Delivery Instructions	Optional. Enter text describing any special delivery instructions for the item(s).
Receiving Address	Display-only after the PO has been approved. Defaults to the central receiving address from the requisition. May be changed by using the lookup 
Use Receiving Address as Shipping Address Presented to Vendor	Required. Defaults to the indicator selected on the requisition.

Editing a Building Address



The address is completely editable before the PO is approved. Take the following steps to add an address for another building.

- Click the **building not found** button.

The delivery address fields become editable.

Delivery ▼ hide

Final Delivery

* Delivery Campus:	BL 
Building:	 building not found
* Address 1:	<input type="text"/>
Address 2:	<input type="text"/>
* Room:	<input type="text"/>
* City:	<input type="text"/>
* State:	<input type="text" value="▼"/>
* Postal Code:	<input type="text"/>
Country:	<input type="text" value="▼"/>

Receiving Address

	Receiving Address:
	KUALI 400 E. Centra Kuali C UNITE

Address To Vendor

Shipping Address Presented to Vendor (us

- Enter the delivery address.

Tip

To search for a delivery address, click the search icon  next to **Building** and select a building from the lookup.

Vendor Tab

On an approved purchase order, the **Vendor** tab identifies the vendor that was awarded the PO. The default is the vendor selected on the requisition. Although most field entries in this tab default to the values provided on the associated requisition (REQS) document or from the vendor's default information, the entries may be modified. If a vendor was not supplied already, you must add one.

Note

With open Purchase Orders, there is an additional required field for **Vendor Choice**. Select one of the options from the drop down list.

Vendor		hide
Vendor Address		
Vendor Alias Name:	YBP <input type="button" value="select vendor"/>	
* Vendor:	YBP Library Services <input type="button" value="search"/>	
Vendor #:	12106-0	*required
* Address 1:	999 Maple Street <input type="button" value="search"/>	Pro
Address 2:	<input type="text"/>	Postal *required
Attention:	<input type="text"/>	* Co
Vendor Info		
* Vendor Choice:	Contracted Price <input type="button" value="dropdown"/>	
Acquisition Unit's Vendor account / Vendor Info Customer # :	<input type="text"/> <input type="button" value="search"/>	
Notes To Vendor:	<input type="text"/>	Payment T Shipping Shipping Payment T
Contract Name:	<input type="text"/> <input type="button" value="search"/>	Co
Phone Number:	<input type="text"/> <input type="button" value="search"/>	Supplier Div
Fax Number:	<input type="text"/>	
		Alternate Vendor For Non-P Vendor Pay

The **Vendor** tab includes two sections: **Vendor Address** and **Vendor Info**.

Vendor Address Section

The Vendor Address section lists address information about the vendor for this purchase order.

Vendor Address	
Vendor Alias Name:	YBP <input type="button" value="select vendor"/>
* Vendor:	YBP Library Services <input type="button" value="search"/>
Vendor #:	12106-0
* Address 1:	999 Maple Street <input type="button" value="search"/>
Address 2:	<input type="text"/>
Attention:	<input type="text"/>

Ordering Materials: Standard
Transactional E-Docs

Vendor Address section definition

Title	Description
Vendor Alias Name	The abbreviated code, or alias, of the vendor. Enter the code and click  to prepopulate the vendor information.
Vendor	Required and Display-only. The vendor's name is automatically updated from the Vendor record.
Vendor #	Display-only. The OLE-generated identifying number assigned to this vendor.
Address 1	Required. The default address is the PO address defined as the default for the campus. This field is editable.
Address 2	Optional. The default address is the PO address defined as the default for the campus. This field is editable.
Attention	Optional. If the attention line on the PO address is present this information will be populated although this field is always editable.
City	Required. Enter the city associated with this vendor address.
State	Enter the state's abbreviation. States are required for US addresses.
Province	Optional. Non-U.S. vendor addresses may include a province. Enter the province here. This field should always be used for Canadian vendors.
Postal Code	Enter the postal code for this address. Postal code may be required under certain circumstances (such as when entering a U.S. address).
Country	Required. Select a country from the Country list.

Vendor Info Section

Vendor Info	
* Vendor Choice:	Contracted Price
Acquisition Unit's Vendor account / Vendor Info Customer # :	<input type="text"/>
Notes To Vendor:	<input type="text"/>
Contract Name:	<input type="text"/>
Phone Number:	<input type="text"/>
Fax Number:	<input type="text"/>
	Payment Terms: Net 30 Days
	Shipping Title:
	Shipping Payment Terms: INST PAYS, PART OF PO ("PREPAID
	Contacts:
	Supplier Diversity:
	Alternate Vendor For Non-Primary Vendor Payment:
	Search for alternate vendor 
	Vendor Name: Vendor #: <input type="button" value="remove alternate vendor"/>

Vendor Info section definition

Title	Label
Vendor Choice	Required. Select the reason that this vendor was selected to fill this purchase order from the Vendor Choice list.
Acquisition Unit's Vendor acct/Vendor Info Customer #	Optional. Enter or look up a customer number that identifies your institution or department for this vendor's reference.
Notes to Vendor	Optional. Include any text you want the vendor to see on the PO.
Contract Name	Optional. If a contract exists with the vendor for these goods or services, search for it from the Contact lookup  .
Phone Number	Optional. Enter the selected vendor's phone number. (Formatted: xxx-xxx-xxxx)
Fax Number	Optional. Enter the selected vendor's fax number.
Payment Terms	Optional. Select the payment terms from the Payment Terms list.
Shipping Title	Optional. Select the shipping title from the Shipping Title list.
Shipping Payment Terms	Optional. Select the shipping payment terms from the Shipping Payment Terms list.

Ordering Materials: Standard Transactional E-Docs



Contacts	Optional. If the vendor has multiple contacts, select the appropriate contact for this PO.
Supplier Diversity	Display-only. The information appears if the selected vendor has been assigned a supplier diversity type.
Alternate Vendor for Non-Primary Vendor Payment	Optional. Used any time a purchasing needs to give accounts payable the option to pay one vendor or another. Examples include third-party receivables or escrow accounts for construction payments. To search for a vendor, use the lookup  . To remove an alternate vendor, click remove alternate vendor .

Stipulations Tab

The **Stipulations** tab allows for the entry of stipulations for the vendor filling this PO. It may also be used for any additional contractual information that should be added to the PO.



Stipulations tab definition

Title	Description
Note Text	Required. Enter text to be viewed by the vendor of this PO or search for pre-defined text from the lookup  .
Actions	Click  to add new text.

Titles Tab

The **Titles** tab identifies what is being ordered on the PO and establishes the accounting distribution for payments. Before the PO has been approved, you may change or add to the items and accounts that have been carried over from the requisition. You may also add additional charges or apply PO total reductions here. Make sure you have bibliographic information in the **Bib Info** fields and complete accounting lines.

Ordering Materials: Standard
Transactional E-Docs

Titles ▼ hide

Add Item ?

Bib Info: <input type="radio"/> new bib <input type="radio"/> existing bib					Location		
* No of Copies Ordered	<input type="text" value="1"/>	* No of Parts Ordered	<input type="text" value="1"/>	* List Price	<input type="text" value="0.00"/>	Extended Cost	0.00
Receipt Status		No Of Copies Received		No Of Parts Received		Item Price Source	Publisher
Format	<input type="text"/>	Category	<input type="text"/>	Vendor Item Identifier		Requestor	HUNTLEY, KEIS
* Unit Cost		Discount	<input type="text" value="0.00"/>	Discount Type	<input type="text" value="%"/>		

Current Items

Item 1

Bib Info: <u>LOVE AND GYMNASTICS; TRANS. BY DAVID CHAPMAN.,DE AMICIS, EDMONDO, 1846-1908,HESPERUS PRESS,9781843911937</u>					Location	ARCH/P	
* No of Copies Ordered	<input type="text" value="1"/>	* No of Parts Ordered	<input type="text" value="1"/>	* List Price	<input type="text" value="14.95"/>	Extended Cost	14.95
Receipt Status		No Of Copies Received		No Of Parts Received		Item Price Source	Publisher
Format	<input type="text"/>	Category	<input type="text"/>	Vendor Item Identifier	100525961	Requestor	<input type="text"/>
Unit Cost	14.95	Discount	<input type="text"/>	Discount Type	<input type="text" value="%"/>		

Notes
 Accounting Lines
 Payment History

Additional Charges

Totals

Grand Total:	
Internal Purchasing Limit:	10

Add Item and Current Items Sections

Add Item ?

Bib Info: <input type="radio"/> new bib <input type="radio"/> existing bib					Location		
* No of Copies Ordered	<input type="text" value="1"/>	* No of Parts Ordered	<input type="text" value="1"/>	* List Price	<input type="text" value="0.00"/>	Extended Cost	
Receipt Status		No Of Copies Received		No Of Parts Received		Item Price Source	
Format	<input type="text"/>	Category	<input type="text"/>	Vendor Item Identifier		Requestor	
* Unit Cost		Discount	<input type="text" value="0.00"/>	Discount Type	<input type="text" value="%"/>		

Current Items



Item 1

Bib Info: <u>LOVE AND GYMNASTICS; TRANS. BY DAVID CHAPMAN.,DE AMICIS, EDMONDO, 1846-1908,HESPERUS PRESS,9781843911937</u>					Location		
* No of Copies Ordered	<input type="text" value="1"/>	* No of Parts Ordered	<input type="text" value="1"/>	* List Price	<input type="text" value="14.95"/>	Extended Cost	
Receipt Status		No Of Copies Received		No Of Parts Received		Item Price Source	
Format	<input type="text"/>	Category	<input type="text"/>	Vendor Item Identifier	100525961	Requestor	
Unit Cost	14.95	Discount	<input type="text"/>	Discount Type	<input type="text" value="%"/>		

Ordering Materials: Standard
Transactional E-Docs

Add Item and **Current Items** sections contain the same fields.

Add Item and Current Items section definitions

Title	Description
Bib Info	Choose  to link to the Bib Editor. Titles will appear in the after an item has been added. In Current Items , you may click the title link to open the bibliographic editor.
Location	Select the home location for the item.
No of Copies Ordered	Required. Enter the quantity of the item in this field.
No. of Parts Ordered	This is the number of individual pieces that must be accounted for upon payment/receipt of a requisitioned item.
List Price	Basic price of an item before any discounts are taken.
Extended Cost	Display-only. No of Copies ordered multiplied by the list price minus any discount.
Public View	Optional. Indicates whether or not a bibliographic description shall be exposed to users prior to purchase/receipt. Default is Yes (checked).
Currency Type	Display only if foreign vendor is chosen. Identifies the associated vendor's currency as identified on the vendor record that is identified in the Link to Vendor/Supplier.
Exchange Rate	Display only if foreign vendor is chosen. Currency conversion rate populates from the Exchange rate and Currency Type maintenance tables. The rate will populate when user clicks action button "Calculate" on conversion tab. Optionally: when currency tab opens, currency rate may auto-populate. This may be updated up until the Requisition is approved. After that point, it may no longer be modified.
Foreign List Price	Basic foreign price of an item before any discounts are taken.
Receipt Status	Display only. Will reflect receipt status after receiving has occurred.
No Of Copies Received	Display only. The number of copies already received. This will populate as the document moves through the acquisition workflow.
No Of Parts Received	Display only. The number of parts already received. This will populate as the document moves through the acquisition workflow.
Item Price Source	Optional. Select the Price Source of the requested item from the dropdown list.
Request Source	Optional. Select the Request Source of the requested item from the dropdown list.
Format	Optional. Select the format of the requested item from the dropdown list.
Category	Optional. Select a Category of the item from the dropdown list..
Vendor Item Identifier	Display Only. Identifies a vendor item identifier if one has been provided by a vendor.
Requestor	Defaults to the selector's user name. If the Requestor is different than the selector, you may use the Requestor lookup  to find the requesting individual's name or create a new Requestor (this will search from the OLE Patron database).
Route to Requestor	Optional. Yes/No checkbox to indicate whether a requestor should be notified when the item has been purchased. System default data value is "No".
Foreign Unit Cost	Display only if foreign vendor is chosen. Calculated foreign cost per unit for the item or service on this line. Calculation is the Foreign List Price less Foreign Discount amount.
Discount	Discount provided by the vendor/customer number/organization combination. Automatically populated from the Vendor customer number table based on the selected vendor and customer number. Can be modified for a specific title. If the vendor record has a Vendor currency noted other than the default system currency (aka US dollar), then the Vendor discount will populate the Foreign Discount field.
Discount Type	Choose # (for Amount) or % (for Percentage).
Foreign Discount	Foreign discount provided by the vendor/customer number/organization combination when the vendor record has a Currency Type different from

Ordering Materials: Standard Transactional E-Docs

	the system default currency. Should be automatically populated from the Vendor customer number table based on the selected vendor and customer number. This data can be changed for the specific title. Must identify the type of discount (amount or %.) If the vendor record does not have a Currency Type noted other than the default system currency (aka US dollar), then the discount should populate the Discount field.
Foreign Discount Type	Choose # (for Amount) or % (for Percentage).
Actions	Add or delete lines as appropriate. After a line has been added, it is moved to the Current Items section, where the details may be viewed or modified.

Adding or Modifying an Item

Inactivate Button: The **inactivate** button becomes available only when you are amending a PO. If while amending a PO you would like to deactivate a line item, click the **inactivate** button associated with that item.

Note

For more information about how to amend the PO, see [Purchase Order Amend](#).

When processing an amendment to a PO, you may deactivate item lines that are no longer valid. To do so, select the **Inactivate** check box next to the appropriate items. When the amendment is approved, these items are no longer valid for this PO.

Current Items							
Item 1							
Bib Info:	LOVE AND GYMNASTICS; TRANS. BY DAVID CHAPMAN,,DE AMICIS, EDMONDO, 1846-1908,HESPERUS PRESS,9781843911937					Location	ARCH/PS
* No of Copies Ordered	<input type="text" value="1"/>	* No of Parts Ordered	<input type="text" value="1"/>	* List Price	<input type="text" value="14.95"/>	Extended Cost	14.95
Receipt Status		No Of Copies Received		No Of Parts Received		Item Price Source	Publisher
Format	<input type="text"/>	Category	<input type="text"/>	Vendor Item Identifier	100525961	Requestor	<input type="text"/>
Unit Cost	14.95	Discount	<input type="text"/>	Discount Type	<input type="text" value="%"/>		

Click  to add a line. The system will move it to the **Current Items** section.

Note

To add an item, you must follow the same procedure described in [Working in the Titles Tab](#) on the Requisition section (First add the bibliographic record, fill in the purchasing information, then click add).

Click  to delete a line.

Click  to view the additional details (notes, accounting lines, payment history).

Additional Charges Section

The Additional Charges tab allows lines for predetermined charges to be included on the payment request. This tab is divided into four charge lines, each representing a different type of charge, each with its own accounting lines, and a series of options through which the amounts added in this section can be prorated to the existing line items in the Current Items sub tab. The four Additional Charges lines are **Freight**, **Shipping and Handling**, **Full Order Discount**, and **Trade In**.

Note

The Additional Charge Trade In will be removed in a later release.

Additional Charges hide					
* Item Type	Description	Extended Cost	Tax Amount	Total Amount	
Trade In					
Trade In :	<input type="text"/>	<input type="text"/>	0.00	0.00	
show Accounting Lines					
Shipping and Handling					
Shipping and Handling :	<input type="text"/>	<input type="text"/>	0.00	0.00	
show Accounting Lines					
Freight					
Freight :	<input type="text"/>	<input type="text"/>	0.00	0.00	
show Accounting Lines					
Full Order Discount					
Full Order Discount :	<input type="text"/>	<input type="text"/>	0.00	0.00	
show Accounting Lines					

Additional Charges section definition

Title	Description
Item Type	Display-only. Describes the type of miscellaneous item ('Freight' or 'Shipping and Handling') being defined in this line.
Description	Required if the extended cost has been entered. Enter a text description describing the additional charges item line.
Extended Cost	Required. Enter the dollar amount for this item line.
Total Amount	Display-only. Automatically calculated based on responses in other fields. Displays the total of the requisition after fees.

Totals Section

Totals	
	Grand Total:
	Internal Purchasing Limit:

Totals section definition



Title	Description
Grand Total	Display-only. Displays a total of all current item lines and additional charges lines.
Internal Purchasing Limit	Display-only. Displays the dollar amount of the maximum purchasing limit, above which a PO will route for approval.

Creating Accounting Distributions in the Titles Section

Accounting distributions for item lines may be created individually, or a single accounting distribution may be copied to all line items on the requisition. A valid account string contains a chart, an account, and an object code. The account must be active and the expiration date has not expired. The object code must valid. Valid object codes are active codes in the object code table and are *not* included in the OBJECT CONSOLIDATION parameter.

To create accounting distributions for individual item lines, follow these steps.

17. Click **add** in the **Actions** column to add the item line.

18. In the **Current Items** section, click the  button for the line to which you want to add an accounting distribution.
19. In the **Item Accounting Lines** section, click the  button.
20. Complete the accounting line and indicate a percent of this item line that should be charged to this accounting line. If there is only one accounting line for this item, the percent must be 100.
21. Click  to add the accounting line.
22. If the item needs to be distributed to more than one accounting line, repeat steps 4 and 5. The sum of all accounting lines must equal 100 percent when you finish the distribution.



Note

If the account chosen has sufficient funds checking and the threshold is reached, you may be blocked from using the account or you may receive a warning (depending on the chosen notification on the account) when the document is saved and the Fiscal Officer will be notified when the document is submitted.

Note

This process may also be followed to add accounting distribution lines for items in the **Additional Charges** section. Open the **Accounting Line Items** section for that miscellaneous line item and follow steps 4-6 above.



Line item accounting can create considerable repetitive data entry. OLE allows you to load the information to all the line items rather than entering the information to each line item separately. The steps below describe how to distribute this information. This process distributes accounts only to line items that have no accounts added. It does not replace accounts that have been set up for individual line items.

23. Click  to add the item line.
24. In the **Add Item** section, click the  button.

The system opens a new **Accounting Lines** section.
25. Enter the accounting line and indicate the percent of this item line that is to be distributed to the items on this requisition. If there is a single accounting line for these items, the percent must be 100.

Note

The system validates values as you enter the information.

26. Click  to add the accounting line.
27. If the items need to be distributed to more than one accounting line, repeat steps 3 and 4. The accounting lines distribution should total 100%.
28. Click the  button to apply this distribution to all item lines that do not yet have an accounting line distribution specified.

The system displays the top of the document and the message 'The accounts were successfully distributed to all items'.

Removing Accounts from all Item Lines

If line items have accounts set up and those accounts need to be modified, then the individual accounting lines may be modified by following the steps for creating an accounting distribution for an individual item line discussed in the previous section. However, if it is more efficient to remove all the accounts, use the steps for creating an accounting distribution for multiple line items to recreate the accounting for the line items.

Follow these steps to remove all accounts.

29. Click  .

30. Click  in response to the question 'Are you sure you want to remove the accounts from ALL items?'

All the accounting lines are removed.

Expand All Accounts

To expand the accounting lines for all the items in the **Current Items** section, follow these steps. (This is the equivalent of clicking the accounting lines' **show** button for each item listed.)

31. Click  .

32. All accounts are displayed in full detail.

Collapse All Accounts

To collapse the accounting lines for all items in the **Current Items** section, follow these steps. (This procedure is the equivalent of clicking the Accounting Lines **hide** button for each item listed.)

33. Click **collapse all accounts**.

34. All account displays are hidden.

Payment Info Tab



If recurring payments are required for the items on this PO, this tab is used to indicate the type of payment schedule required and the duration of that schedule. The fields in this tab are informational only. They do not drive any other functions within OLE.

Payment Info	
Payment Info	
Type of Recurring Payment:	<input type="text"/>
Begin/End Date:	from: <input type="text"/> to: <input type="text"/>
Please provide the following recurring payment information if the type of recurring payment is Fixed Schedule, Fixed Amount	
Recurring Payment Amount:	Amount: <input type="text"/> First Payment Date: <input type="text"/> Frequency: <input type="text"/>
Initial Payment Amount:	Amount: <input type="text"/> Date: <input type="text"/>
Final Payment Amount:	Amount: <input type="text"/> Date: <input type="text"/>
Billing Address	
Address:	THE UNIVERSITY ACCOUNTS PAYABLE BUTTER NUT , SC 47402 US

The **Payment Info** tab includes **Payment Info** and **Billing Address** sections.

Payment Info Section

Payment Info section definition

Title	Description
Type of Recurring Payment	Optional. Select the proper recurring payment schedule from the list. Examples include 'Fixed Schedule, Fixed Amount,' 'Fixed Schedule, Variable Amount' and 'Variable Schedule, Variable Amount'.
Begin/End Date	Required if Type of Recurring Payment has been selected. Enter dates indicating the time period during which the order is active, or search for the dates from the calendar 
Recurring Payment Amount	Optional. If a recurring payment type of 'fixed schedule' or 'fixed amount' has been selected, complete the remaining fields in this section.
Amount	Optional. Enter the dollar amount of the recurring payment.
First Payment Date	Optional. Enter the date on which the first recurring payment should be made or search for the date from the calendar  . This date is used to determine subsequent payments based on the frequency. For example, if the frequency is 'monthly' and the first payment date is 01/01/2010, the subsequent payments occur on the first of the month.
Frequency	Optional. Select a number to indicate how often recurring payments should be made.
Initial & Final Payment Amount	Optional. Enter the amount of the initial and final payments if those amounts differ from the amount in the Amount field above.
Initial & Final Payment Date	Optional. Enter the dates on which the initial and final payments are to be made if those dates differ from the date in the First Payment Date field. Or search for the dates from the calendar 

Billing Address Section

Billing Address section definition



Title	Description
Address	Display-only. The address to which vendor invoices are to be mailed. This address is based on the campus specified for delivery on the Delivery tab.

Additional Institutional Info Tab

The **Additional Institutional Info** tab collects information about the organization at your institution that is responsible for initiating this purchase. It also collects information on transmission method and contact information.

Additional Institutional Info ▼ hide	
Additional	
* Method of PO Transmission:	PRINT ▼
* Cost Source:	ESTIMATE ▼
Contact Name:	<input type="text"/> 
Contact Phone:	<input type="text"/>
Contact Email:	<input type="text"/>
PO Total Cannot Exceed:	<input type="text"/>

Additional Institutional Info tab definition

Title	Description
Method of PO Transmission	Required. Select the transmission method. Normally this is 'Print,' but if for some reason you do not need to print a copy of the PO for the vendor, you may choose 'No Print'.
Cost Source	Required. This field indicates how the pricing on the PO was determined. Select the appropriate cost source from the list.
Contact Name	Optional. Enter the name of the person to be contacted if Purchasing (or vendor if the order is an APO) has questions about the order or search for it from the Person lookup  .
Contact Phone	Optional. Enter the phone number of the person specified in the Contact Name field. (Formatted: xxx-xxx-xxxx)
Contact Email	Optional. Enter the email address of the person specified in the Contact Name field.
PO Total Cannot Exceed	Optional. This information is typically entered on the requisition and indicates to Purchasing that the order has a limited amount of resources.
Requestor Name	Required. The name of the person who requested the goods or services. This field may be changed by entering a new name or searching for it from the Person lookup  .
Requestor Phone	Required. Enter the phone number of the person specified in the Requestor Name field. (Formatted: xxx-xxx-xxxx)
Requestor Email	Required. Enter the email address of the person specified in the Requestor Name field.
Sensitive Data	Display-only. This displays the currently assigned sensitive data entries created using the sensitive data button at the bottom of the document.

Quote Tab

Note

Quotes are remaining functionality from KFS. This will be removed in a future release.

Account Summary Tab

The **Account Summary** tab combines all accounting information for the items on this PO for future reference.

Ordering Materials: Standard Transactional E-Docs

Account Summary ▼ hide									
Account Summary refresh account summary									
Account Summary 1									
Chart	Account Number	Sub-Account	Object	Sub-Object	Project	Org Ref Id	Org. Doc. #	Amt	
BL	1031400		5000					119.10	
Items of Account Summary 1									
Item	Description							Amount	
Item 1	78 : The Boston Red Sox, a Historic Game, and a Divided City							53.88	
Item 2	Faithful : Two Diehard Boston Red Sox Fans Chronicle the Historic 2004 Season							38.46	
Item 3	The Boston Red Sox: An Illustrated History							26.76	

Clicking the **refresh account summary** button reloads the page and adds any accounts and/or line items that the user may have just added to the PO.

View Related Documents Tab

The **View Related Documents** tab collects information about Purchasing/AP documents related to this document. For example, it displays identifying information for any associated requisition, payment requests, or credit memos.

View Related Documents ▼ hide		
Related Documents		
Requisition - 1064 ▼ hide		
Date	User	
2013-08-19 15:34:58.0	HUNTLEY, KEISHA Y	copied from document 4537

View Related Documents tab definition

Title	Description
Date	Display-only. The date the related document was created.
User	Display-only. The user who created the related document. 'Kuali System User' means the document was automatically created by the system.
Note	Display-only. The note describing the document.

When you click the document number link, the system displays the related document in a separate window.

View Payment History Tab

The **View Payment History** tab lists all the payment requests and credit memos that have been issued against the PO.

View Payment History ▼ hide											
Payment History - Payment Requests											
PREQ #	Invoice #	PO #	PREQ Status	Hold	Request Cancel	Vendor Name	Customer #	Amount	Pay Date	PDP Extract Date	Paid?
1061	33	1010	Awaiting Fiscal Officer Approval	No	No	BASIC VENDOR ESTATE/TRUST		999.00	11/12/2009		No
Payment History - Credit Memos											
CM #	Vendor CM #	PREQ #	PO #	Credit Memo Status	Hold	Vendor Name	Customer #	Amount	APAD Date	PDP Extract Date	Paid?
1004	KT	1061	1010	Complete	No	BASIC VENDOR ESTATE/TRUST		10.00	10/15/2009		No
1003	889	1061	1010	Complete	No	BASIC VENDOR ESTATE/TRUST		333.00	10/15/2009		No

View Payment History – Payment Requests section definition

Ordering Materials: Standard
Transactional E-Docs

Title	Description
PREQ#	Display-only. The payment request number.
Invoice #	Display-only. The invoice number.
PO#	Display-only. The purchase order number.
PREQ Status	Display-only. The payment request status.
Hold	Display-only. Displays 'yes' if the payment request is on hold. Displays 'no' if the payment request is not on hold.
Req Canc	Display-only. Displays 'true' if the payment request has been canceled. Displays 'false' if the payment request has not been canceled.
Vendor Name	Display-only. The vendor name.
Customer #	Display-only. The customer number.
Amount	Display-only. The payment request amount.
Pay Date	Display-only. The date to make payment on this payment request.
PDP Extract Date	Display-only. The date the payment request was requested for processing by Pre-Disbursement Processor.
Paid?	Display-only. Displays 'yes' if the payment has been disbursed. Displays 'no' if the payment has not been disbursed.

View Payment History – Credit Memos section definition

Title	Description
CM#	Display-only. The credit memo number defined in OLE.
Vendor CM#	Display-only. The credit memo number defined by vendor.
PREQ#	Display-only. The payment request number.
PO#	Display-only. The purchase order number.
Credit Memo Status	Display-only. The credit memo status.
Hold	Display-only. Displays 'yes' if the credit memo is on hold. Displays 'no' if it is not on hold.
Vendor Name	Display-only. The vendor name.
Customer #	Display-only. The customer number.
Amount	Display-only. The credit memo amount.
APAD Date	Display-only. The Accounts Payable approved date (that is, the date the Accounts Payable review group approved the credit memo).
PDP Extract Date	Display-only. The date the credit memo was requested for processing by Pre-Disbursement Processor.
Paid?	Display-only. Displays 'true' if a payment has been disbursed to which this credit memo was applied. Displays 'false' if it has not yet been included in a payment.

General Ledger Pending Entries Tab

G/L Pending Ledger entries are generated after the PO document is submitted. These entries include the encumbrances for the transaction and the appropriate offsetting entry. After the nightly batch jobs run to post the G/L entries, these pending entries no longer display here.

General Ledger Pending Entries												
Seq #	Fiscal Year	Chart	Account Number	Sub-Account	Object	Sub-Object	Project	Doc Type	Balance Type	Obj. Type	Amount	D/C
1	2010	BL	1031400	----	5000	---	-----	PQ	EX	EX	999.00	D
2	2010	BL	1031400	----	9892	---	-----	PQ	EX	FB	999.00	C

General Ledger Pending Entries tab definition

Title	Description
Seq #	Display-only. Assigns a number to the entry in sequential order.
Fiscal Year	Display-only. Identifies the fiscal year of the debit or credit.

Ordering Materials: Standard Transactional E-Docs

Chart	Display-only. Identifies the chart to which the pending entry is assigned.
Account	Display-only. Identifies the account number to which the pending entry is assigned.
Sub-Account	Display-only. Identifies the sub-account, if one exists, to which the pending entry is assigned.
Object	Display-only. Identifies the object code of the item being ordered.
Sub-Object	Display-only. Identifies the sub-object code of the item being ordered, if one exists.
Project	Display-only. Identifies the project code, if one exists, to which the PO is assigned.
Doc. Type Code	Display-only. Identifies the document type code of the document. When working with POs, this value will almost always be PO.
Balance Type	Display-only. Identifies the different balances (actuals, budget, encumbrances, etc.) recorded in OLE to facilitate reporting and financial queries.
Obj. Type	Display-only. Categorizes object codes into general categories identifying income, expenses, assets, liabilities, fund balance or transfers.
Amount	Display-only. Indicates the amount charged to each account on the PO.
D/C	Display-only. Indicates whether the entry is a debit (D) or credit (C) to the account.

Process Overview

Business Rules

- All required fields must be completed before the PO document can be submitted for approval.
- The **Bib Info** field on the **Item** tab must be completed.
- The PO generates encumbrances when it reaches a workflow status of 'FINAL'. Encumbrances are created on the accounts and object codes entered in the item sections and the appropriate offset object code(s).
- An APO document may be created only under certain conditions, as specified in the business rules set up by the institution. Examples of conditions that might prevent an APO from being created are:
 - The requisition total is greater than the APO limit.
 - The requisition total is not greater than zero.
 - The requisition contains an item that is marked as restricted.
 - The vendor was not selected from the vendor database.
 - An error occurred while retrieving the vendor from the database.
 - The selected vendor is marked as restricted.
 - The requisition has no contract selected, but a contract exists for the selected vendor.
 - The requisition's payment type is marked as recurring (**Payment Info** tab).
 - The 'PO Total Cannot Exceed' amount has been entered (**Additional Institutional Info** tab).
 - The requisition contains alternate vendor names.

- The requisition is set to encumber during the next fiscal year (chosen from **Year** in the **Document Overview** tab) and approval is not within the APO allowed date range. The date range is determined by the 'ALLOW APO NEXT FY DAYS' parameter.
- The requisition contains a full order discount.
- The requisition contains accounting strings with an object level in the OLE-PURAP:PURCHASING_ACCOUNTS_PAYABLE_OBJECT_LEVELS parameter (currently set to CAP).

Routing

The PO document does the following types of routing:

- **Budget Office Review:** If the PO is for the current fiscal year, all accounts used on the document are checked to see if any of accounts use sufficient funds checking. If the encumbrances from this order would cause these accounts to have insufficient funds, the PO document routes to the Budget Reviewer role for approval.
- **Document Transmission:** If the document is an APO, an FYI is generated back to the initiator of the requisition document. If the document is not an APO, an FYI is generated back to the user who submitted the PO.

Ordering Materials: Standard
Transactional E-Docs

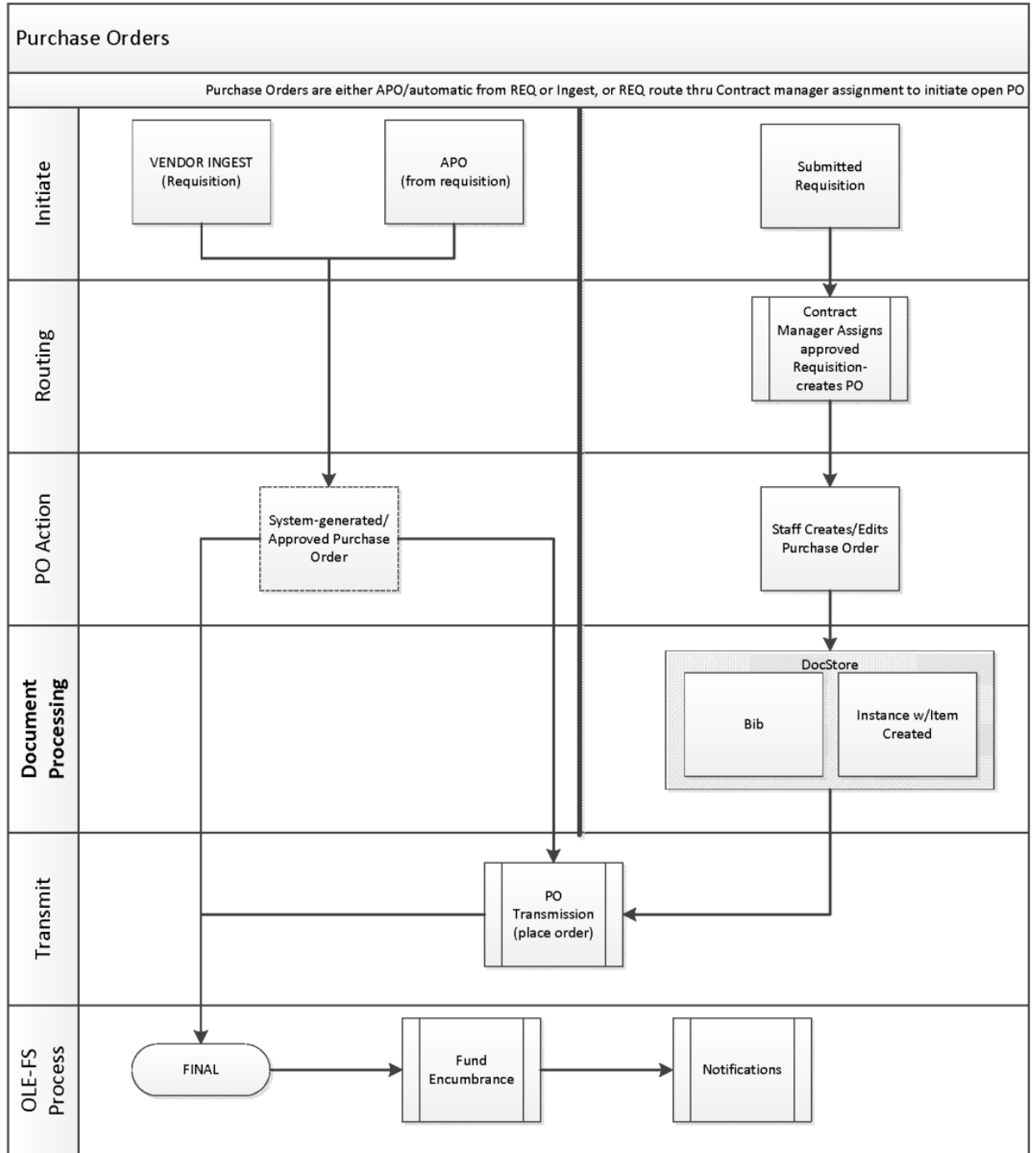

Processing a PO Document

35. Search for 'In Process' purchase orders using the Order Holding Queue or document search and click the document ID to open it.

The system displays a PO document populated with information from the requisition.

36. Complete the standard tabs as necessary.

Note

For information about the standard tabs such as **Document Overview**, **Notes and Attachments**, **Ad Hoc Recipients**, **Route Log**, and **Accounting Lines** tabs, see [Standard Tabs](#) on the *OLE E-Doc Fundamentals* wiki page.

37. Complete the **Vendor**, **Stipulations**, **Titles**, **Payment Info**, **Delivery**, **Additional Institutional Info** and **other** tabs as necessary. To add information to these sections, click the **amend** button at the bottom of the PO.

38. Click or

If all required fields have been correctly filled in, and you click on **approve**, the system will then approve the Purchase Order. If any required field is blank or contains invalid data, the system places a warning note at the top of the screen, and by the appropriate field. You will be unable to approve the purchase order until you resolve the problem.

The screenshot shows a web interface for a Purchase Order. At the top, there is a header "Purchase Order" with a help icon. Below the header, a red error message states "1 error(s) found on page." A "Document Overview" tab is active, displaying a "hide" button and a red error icon. The error message reads: "Errors found in this Section: This document must be calculated prior to submitting." Below the error, there is a table with two rows. The first row is labeled "Document Overview" and contains a field for "* Description:" with the value "YBP_Firm_Ingest_kyh_03201". The second row is labeled "Organization Document Number:" and contains an empty text input field.

Once a Purchase Order is approved, the system:

- changes the status of the Purchase Order document to Final
- queues it for printing and/or transmission, by whichever method is specified
- returns you to the Main Menu screen.

Transmitting Purchase Order/Place Order

OLE 1.0 is currently setup to place orders as follows:

- Imported vendor orders (paired EDI and MRC files): no transmission
- Staff-generated manual requisitions and approved purchase orders and purchase order amendments: transmit in real-time to vendor FTP site (no staff interface currently exists for transmit confirmation reports etc.).
- If transmit method of Vendor or Purchase Order is set to **no print** with format of FTP, or SFTP, then resulting EDIFACT order file is transmitted to OLE "mock" vendor FTP site per below.

- If transmit method of Vendor or Purchase Order is **print** with format of Email, Fax, etc., then at completion of an approved Purchase Order, a  button will appear on the e-Doc allowing the user to print, email, or fax a PDF of the Purchase Order. The Purchase Order will also route to Acquisitions staff Action Lists as notification to complete the action.

FTP Site (to see transmitted orders):

http://docstore.demo.ole.kuali.org/upload/Order_Records/Orders_To_Be_Processed_By_Vendor/

Sample Purchase Order Statuses:

Code	Status
CANC	Cancelled
CLOS	Closed
OPEN	Open

See all statuses in [Purchase Order Status](#) in the Appendix.

Performing Other Activities on a PO

To facilitate routings and approvals, and maintain detailed audit trails, OLE has adapted the KFS versions of Purchase Orders. Not all of these may be needed in support of future library processes, but we are providing them for review.

After a PO has been initiated, authorized users may perform a variety of activities on it. With the exception of **Print**, each of these actions generates a new OLE document (although the PO number remains the same). The following chart summarizes each action and its corresponding document type. (The document type code for each is listed in parenthesis after the name of the associated button.) The table also indicates whether each action results in transactions to be fed to the G/L process.

The “versions” or e-Docs available are permissions-based, and dependent upon the Purchase Order status in workflows.

Note

For more information about printing a PO, see [Printing a PO](#).

PO document types

Document	Description
Purchase Order Amend (POA)	Makes changes to the existing PO.
Purchase Order Payment Hold (POH)	Indicates that no payments should be processed against this PO.
Purchase Order Remove Payment Hold (PORH)	Changes the status of the PO back to 'Open' so payments can be made. An FYI is also sent to AP to indicate that the hold has been removed.
Purchase Order Void (POV)	Cancels the PO and disencumbers all related items. This option is not available after a payment has been made.
Purchase Order Close (POC)	Closes out any remaining items on this PO and disencumbers any outstanding funds.
Purchase Order Reopen (POR)	Reopens the PO and re-encumbers any accounting lines that were disencumbered when the PO was originally closed.

Note

Those with roles that are able to edit purchase orders will also be able to access and edit the above documents. This includes Acquisitions AQ2-AQ5, Accounting AQ3-AQ4, Financial AQ2-AQ5.

Accessing the Various PO Options

To access any of these options for working with a PO, follow these steps:

39. Search for the PO document and open it.

At the bottom of the open document, the system displays a series of specialized action buttons are displayed at the bottom, each corresponding to a different option.



40. Click the button for the function you want to perform.

After you submit one of the above documents, if you subsequently retrieve the original PO document, the system shows a warning in the upper left corner, indicating that there is a newer version of the PO.

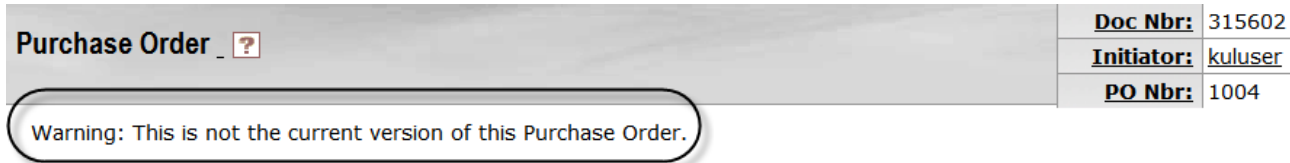

Document Versioning: A single PO document can have several different OLE document numbers assigned. To correlate this information and find the most recent version of a PO, use the Purchase Order menu item in the Custom Document Searches menu group of the Main Menu screen and enter the PO number as a search criteria. In the example shown below, a user amended a PO (POA), placed the PO on hold (POH), removed the hold (PORH), and then created a PO Void (POV). The system retrieved five documents when the user searched on the PO number.

Document Id	Status	Document Description	Organization Document Number	Purchase Order #	Purchase Order Doc Status	Contract Manager Name	Chart/Org	Vendor	University Fiscal Year	Type	Chart Code	Organization Code	Account Number	Ledger Document Type	Total Amount
4102	FINAL	testing around		1038	Open	AUTOMATIC PURCHASE ORDER	UA-VPIT	YBP Library Services	2014	Purchase Order Remove Payment Hold					
4095	FINAL	testing another1		1039	Open	AUTOMATIC PURCHASE ORDER	UA-VPIT	YBP Library Services	2014	Purchase Order Amendment					
4088	FINAL	testing another		1039	Retired Version	AUTOMATIC PURCHASE ORDER	UA-VPIT	YBP Library Services	2014	Purchase Order	BL	EDUC	2947482	OLE_PO	30.00
4079	FINAL	testing around		1038	Retired Version	AUTOMATIC PURCHASE ORDER	UA-VPIT	YBP Library Services	2014	Purchase Order Payment Hold					
4071	FINAL	testing around		1038	Retired Version	AUTOMATIC PURCHASE ORDER	UA-VPIT	YBP Library Services	2014	Purchase Order					
4062	FINAL	test nrs		1037	Void	AUTOMATIC PURCHASE ORDER	UA-VPIT	YBP Library Services	2014	Purchase Order Void					

Printing a PO

The print option allows users with the OLE-PURAP Purchasing Processor role to generate a PDF version of the document to print. The **print** action button becomes available for POs with the 'Pending Print' status.

Note

The **print** button appears on a PO only when the **Method of PO Transmission** is 'PRINT' on the **Additional Institutional Info** tab of the PO and the status of the PO is 'Pending Print'.

Note

There is no document type for the print functionality.



THE UNIVERSITY
PURCHASE ORDER

PO

Vendor BASIC VENDOR ESTATE/TRUST ATTN: null 3388 SOUTH STREET WASHINGTON, KY 44999			Shipping Address RENFROW, ROBERTA G Law Clinic Room #33 624 E 3rd St Bloomington, IN 47405-3602 UNITED STATES			
Shipping Terms Delivery Required By			Payment Terms			
Order Date 10-15-2009		Customer #	Billing Address THE UNIVERSITY ACCOUNTS PAYABLE P.O. BOX 4095 BUTTER NUT, SC 47402 342-456-2398 Invoice status inquiry: http://kuali.org/			
Delivery Instructions		Contact ID				
Vendor Note(s)						
Vendor Specifications and Information						
Item No.	Quantity	UOM	Description	Unit Cost	Extended Cost	Tax Amount
1	3.00	EA	testing	333.0000	\$999.00	\$0.00
					Total Price to	
					Total Tax	
					Total order	
					amount:	

1 Attention IUPUI Suppliers: Please be advised of the new IUPUI Tobacco Policy. Effective August 14, 2006 Tobacco use on sale, including but not limited to smoking, is prohibited on university leased property. This policy applies to anyone on campus. Inclusive are Patients, visitors, faculty, staff, volunteers, physicians, students, contractors/other employees, contractors/suppliers/vendors/representatives. For further information we refer you to: <http://www.iupui.edu/~nosmoke/>.

2 Invoices must be sent showing purchase order number to someone who has money to pay for the purchase.

3 All deliveries are to be made to the address and room number as listed above.

UN SIGNED: This is a TEST PO

SALLY SMITH
UNIVERSITY DIRECTOR OF PURCHASING

For more information contact: RENFROW, ROBERTA

Document (dev)

To print a PO:

41. Search for the PO you want to print from the PO search screen and open the PO.

Tip

You may narrow down the search by selecting "Pending Print" in the **Purchase Order Status** search criteria field.

42. Click  to open a printable PDF version of this PO.

A separate window opens and a PDF version of the PO appears.

43. Close the window after taking the necessary actions, using the PDF toolbar (save, print, etc.).

Purchase Order Amend

OLE allows you to add or modify certain data elements on an approved Purchase Order via a Purchase Order Amendment. By so doing, the system creates a new version of the e-Doc called a Purchase Order Amendment (POA) that can be independently processed or routed. The POA then serves as the new version of the purchase order and will be transmitted to the Vendor.

Purchase Order Amendments are created:

- Manually from the  button on a Purchase Order
- Automatically from the entry of **Unordered line items on Receiving e-Doc**
- Automatically from the entry of **Unordered line items on Payment Request e-Doc**

When you amend a PO, the system creates a PO Amend (POA) document based on the existing PO. Enter a reason when initiating the amendment. When the amendment is submitted, the fiscal officer receives an FYI. This is his or her notification that the order has changed.

Once you supply a reason, OLE will display the Purchase Order, and allow you to change almost any field. (In OLE, accounting lines cannot be edited in the PO Amendment process, but can be changed during the payment request process, except for new lines.)

If you add titles to the Purchase Order or change prices, click the  button at the bottom of the screen.

Document Layout

The document layout of the POA document is identical to that of the original PO, with the addition of a notation regarding status in the Document Header. A notation also displays at the top of the PO document, such as 'Warning: There is a pending action on this Purchase Order.'

Note

For information about the fields on this document, see “Document Layout” under [Purchase Order](#).

Notes and Attachments Tab

When you click the **amend** button to initiate the document, the system automatically inserts note text and the previous PO number in the **Notes and Attachments** tab of both the original PO document and the POA document.

Note

The same note text is placed in the original PO and the amended PO.

Notes and Attachments (1) ▼ hide			
Notes and Attachments			
	Posted Timestamp	Author	* Note Text
add:			<input type="text"/>
1	10/26/2009 03:19 PM	KFS	Purchase Order Amendment 1027 (document id 3320) created for new unordered line items due to Receiving (document id 3319)

Process Overview

Business Rules

- The POA may be initiated only by the members of the Purchasing Processor role; Acquisition Staff 2-5; Receiving 3-4; Accounting 3-4; Financial 2-5.
- The PO must be in an 'Open' status.
- If there are payment requests (PREQs) or vendor credit memos (CMs) in process, the **amend** button is not displayed.
- The system adds a note with the date the amendment was started, the person who started the amendment, the information entered on the "confirm" page, and the previous document number.
- If payment requests (PREQs) or credit memos (CMs) have been processed, the **Receiving Required** field cannot be changed.
- The fiscal year cannot be changed
- If the PO has gone through the quote process, the vendor cannot be changed
- If there are unpaid payment requests (PREQs) or credit memos (CMs), the existing line items cannot be changed.
- If the item invoiced amount is greater than 0, the line item cannot be deleted; it can only be deactivated.
- New line items can always be added.
- If modifying an existing line item, the amount cannot go below what has already been invoiced.
- Inactive items are display-only.
- There must be at least one active line item when the **submit** button is selected.
- The **calculate** button must be pressed prior to submitting the POA if you change the list price of an item or add a new line item.
- Fiscal officers receive an FYI when the amendment is completed.
- During the amend process, the original PO document (before the **amend** button was selected) will have a document status of 'pending amendment' and the newly created document will have a status of 'change

in process'. After the amendment has been submitted, the original document status changes to 'retired version' and the amendment's status changes to 'open'.

- Users are not allowed to create Receiving documents, payment requests, or credit memos against a PO that has a pending amendment.

Routing

- The document becomes 'FINAL' when the POA document is submitted.
- The fiscal officer of an account receives an FYI.

Initiating a POA Document

44. Search for the PO you want to amend from the PO search screen. Open the PO.

45. Click  to make changes to the existing PO.

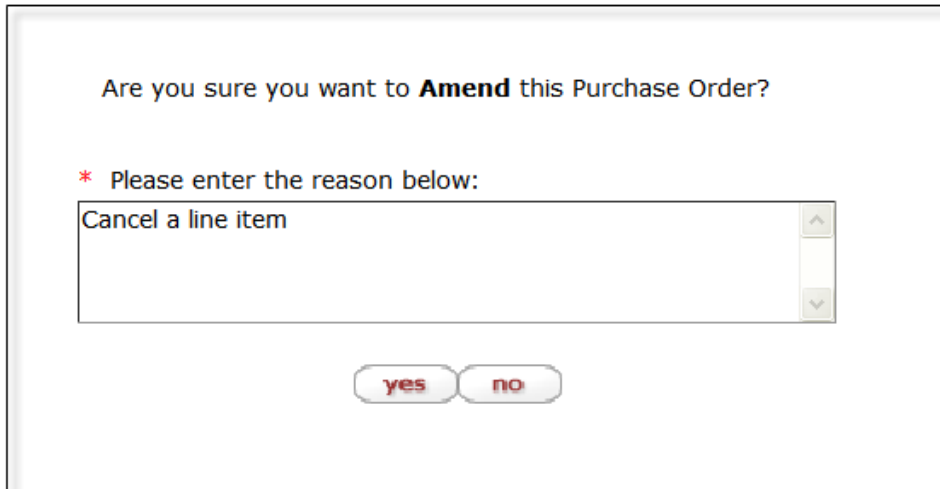

46. Enter a reason explaining why you are amending this PO.



Are you sure you want to **Amend** this Purchase Order?

* Please enter the reason below:

Cancel a line item

47. Click .

The screen refreshes and a new document number (Doc Nbr) is assigned. The PO status becomes 'Pending Amendment'.

<u>Doc Nbr:</u>	317363	<u>Status:</u>	SAVED
<u>Initiator:</u>	philips	<u>Created:</u>	04:26 PM 09/27/2007
<u>PO Nbr:</u>	1048	* <u>PO Status:</u>	Pending Amendment

48. Click the  button on the **Titles** tab and click the **show** button on the item you want to amend.

49. Modify the PO document.

50. Once you are done with your edits, and have recalculated if necessary, you can approve the amended Purchase Order using the **blanket approve** button at the bottom of the screen.

Working with the POA Document

After you create a POA document, you may add, change, or deactivate the existing lines on the original PO.

Note

To add or change the items or accounting lines on the PO, simply add or modify them as you would on the PO document.

Note

An amended Purchase Order follows the same rules for routing as an original PO, so approving it may cause it to be routed to other staff members. Approving an amended PO does not cause it to be re-transmitted to the vendor, though.

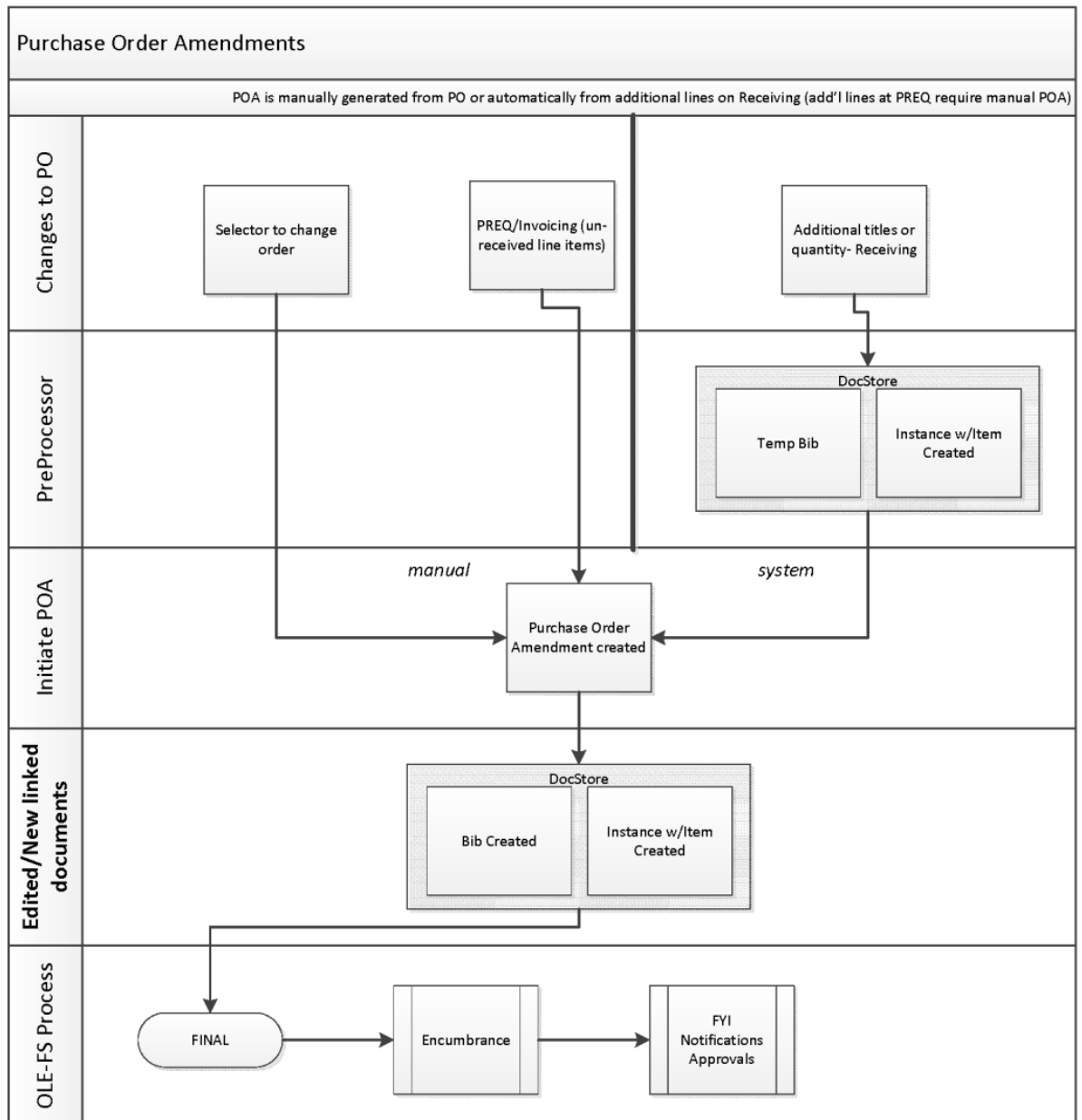

Purchase Order Payment Hold

When you put a PO on hold, the system creates a PO Hold (POPH) document, changes the PO status to 'Payment Held,' and prevents any payment request documents from being initiated against the PO. You must enter a reason when initiating the payment hold.

No G/L pending entries are generated from this document.

Document Layout

The document layout of the POPH document is identical to that of the original PO, with the addition of a notation regarding status in the Document Header. A notation also displays at the top of the PO document, such as 'Warning: There is a pending action on this Purchase Order.'

Note

For information about the fields on this document, see "Document Layout" under [Purchase Order](#).

Notes and Attachments Tab

When you click the **payment hold** button to initiate the document, the system automatically inserts note text in the **Notes and Attachments** tab of both the original PO document and the POPH document.

Notes and Attachments			
	<u>Posted Timestamp</u>	<u>Author</u>	* <u>Note Text</u>
add:			<input type="text"/>
1	09/27/2007 07:37 PM	PHILIPS,KRISTIN U	Note entered while putting a Purchase Order on payment hold : Hold for confirmation of receipt.

Process Overview

Routing

- The document becomes 'FINAL' when the POPH document is submitted.

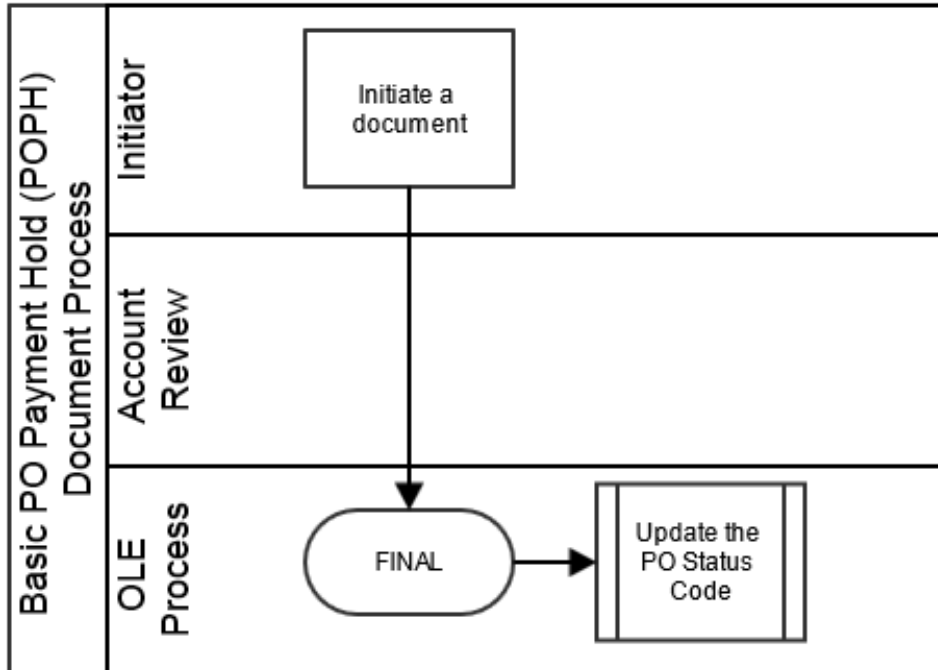

Initiating a POPH Document

51. Search for the PO from the PO search screen and open the PO.

52. Click .

53. Enter the reason for the hold.

Are you sure you want to **Hold Payment** this Purchase Order?

* Please enter the reason below:

Hold for confirmation of receipt.

54. Click .

55. Click  when you see the confirmation message.

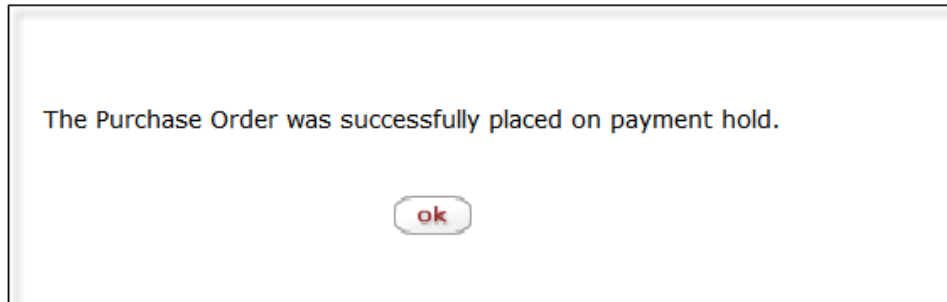

The system displays the main menu.

Purchase Order Remove Payment Hold

When you click the **remove hold** button on a purchase order, the system creates a Remove Hold (PORH) document. This document allows you to remove the hold from a PO document and allow processing of payment requests. The **remove hold** button is available only on the PO documents with 'Payment Hold' status. You must enter a reason when removing the payment hold.

Removing a payment hold changes the Purchase order status back to 'Open'. No G/L pending entries are generated from this document.

Document Layout

The document layout of the PORH document is identical to that of the original PO, with an additional notation regarding the status in the Document Header. A notation also displays at the top of the PO document, such as 'Warning: There is a pending action on this Purchase Order.'

Note

For information about the fields on this document, see “Document Layout” under [Purchase Order](#).

Notes and Attachments Tab

When you click the **remove hold** button to initiate the document, the system automatically inserts note text in the **Notes and Attachments** tab of both the original PO document and the PORH document.

Notes and Attachments (2) hide			
Notes and Attachments			
	<u>Posted Timestamp</u>	<u>Author</u>	* <u>Note Text</u>
add:			<input type="text"/>
1	09/30/2007 11:46 AM	POTTER,PATTI V	Note entered while putting a Purchase Order on payment hold : Hold for confirmation of receipt
2	09/30/2007 11:52 AM	POTTER,PATTI V	Note entered while removing a Purchase Order from payment hold : Goods received. Okay to pay.

Process Overview

Routing

- The document becomes 'FINAL' when the PORH document is submitted.
- Notification may be sent to a user or role defined in the Notification Route level.

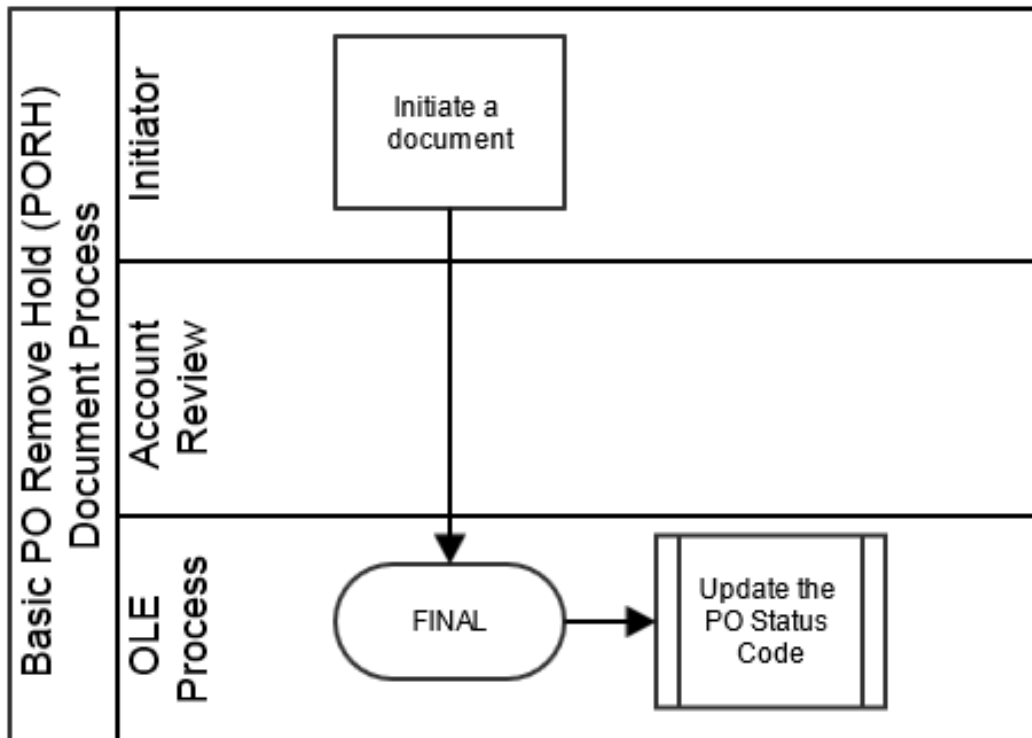

Initiating a PO Remove Hold Document

56. Search for a PO from the PO search screen and open the PO.

Tip

You may search for a PO with a payment held by selecting the 'Payment Hold' in the **Purchase Order Status** option on the PO search screen.

57. Click  to remove the hold from the document.

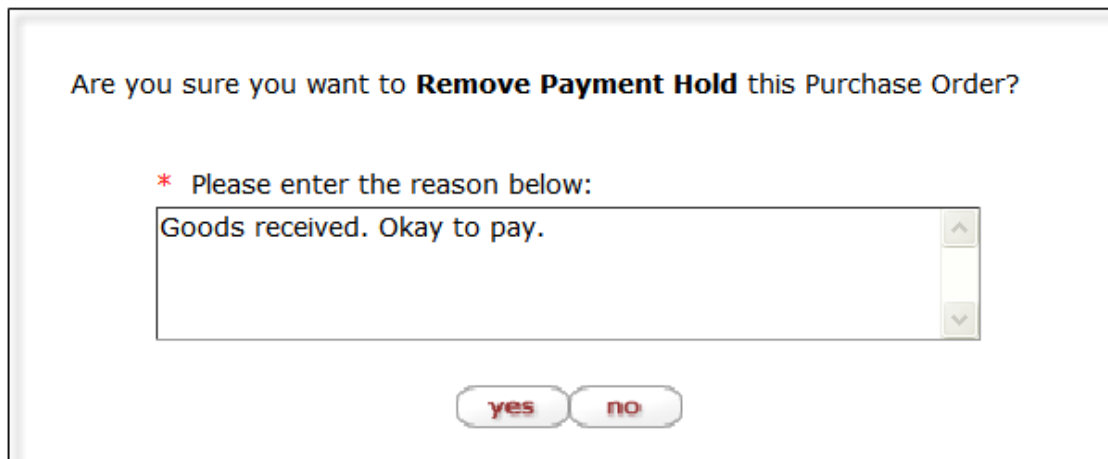

58. Enter the reason for removing the payment hold.



Are you sure you want to **Remove Payment Hold** this Purchase Order?

* Please enter the reason below:

Goods received. Okay to pay.

59. Click .

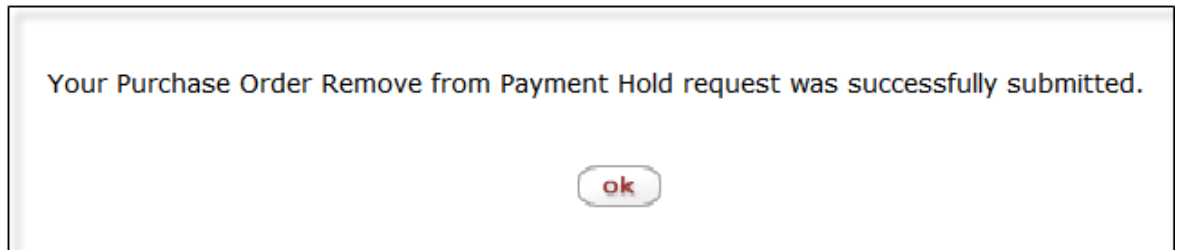

Your Purchase Order Remove from Payment Hold request was successfully submitted.



You are back on the main menu.

Purchase Order Void

If a PO has been fully approved and transmitted to the vendor and no payments have been processed, the Void Order (POV) document allows you to cancel the PO and disencumber all related items. You must enter a reason when initiating the PO void.

Note

The **void order** button is displayed on a PO only if no payments have been processed against it.

Document Layout

When a PO is voided, the system creates a PO Void (POV) document based on the existing PO. The document layout of the POV document is identical to that of the original PO, with an additional notation regarding the status in the Document Header. A notation also displays at the top of the PO document, such as 'Warning: There is a pending action on this Purchase Order.'

Note

For information about the fields on this document, see “Document Layout” under [Purchase Order](#).

General Ledger Pending Entries Tab

When the POV document is successfully submitted, the **General Ledger Pending Entries** tab displays the transactions that will disencumber the total funds associated with this PO. This document reverses the encumbrances that were created by the purchase order.

General Ledger Pending Entries									
Seq #	Fiscal Year	Chart	Account Number	Sub-Account	Object	Sub-Object	Project	Doc Type	Balance Type
1	2010	BA	1031400	----	4000	---	-----	PQ	EX
2	2010	BA	1031400	----	9892	---	-----	PQ	EX

Note

For information about the fields on this tab, see “Document Layout” under [Purchase Order](#).

Notes and Attachments Tab

When you click the **void order** button to initiate the document, the system automatically inserts a note text in the **Notes and Attachment** tab of the original PO document and the POV document.

Notes and Attachments (2)			
	Posted Timestamp	Author	* Note Text
add:			<input type="text"/>
1	09/27/2007 05:52 PM	PHILIPS,KRISTIN U	Note entered while amending a Purchase Order : Cancel a line item (Previous Document Id is 317378)
2	09/28/2007 02:53 PM	PHILIPS,KRISTIN U	Note entered while voiding a Purchase Order : Voiding the PO per department

Process Overview

Business Rules

- The void option is available only if no payments have been issued against this PO.

Routing

- The document becomes 'FINAL' when the POV document is submitted.

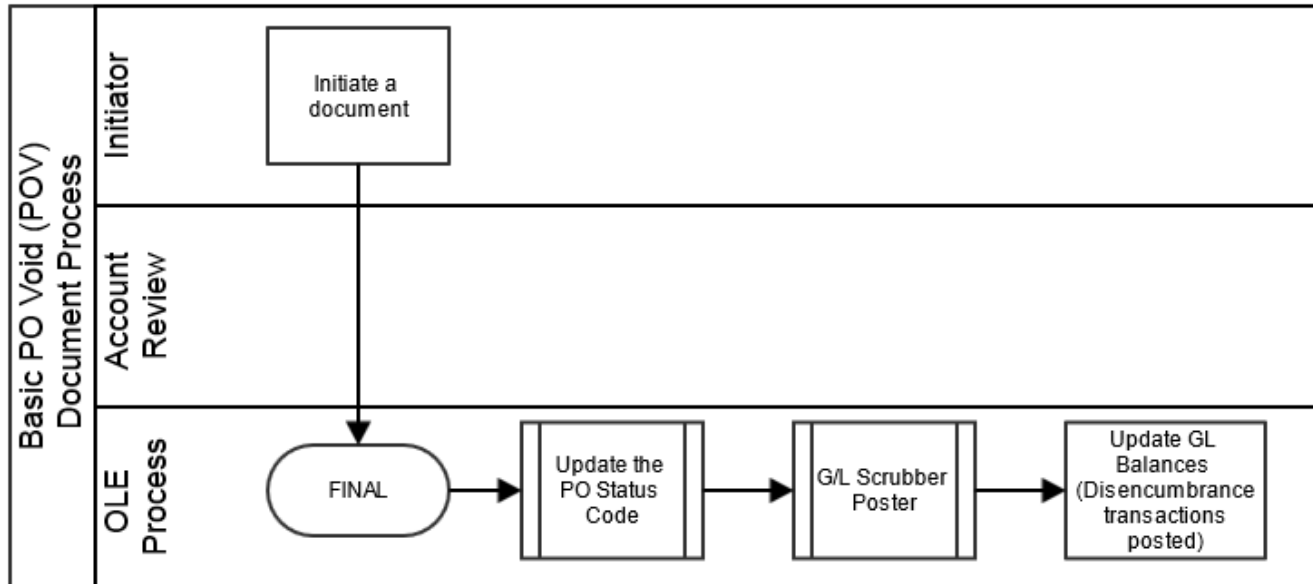

Initiating a PO Void Document

- Search for the PO you want to void from the PO search screen and open the PO.
- Click **void order** to cancel the PO.
- Enter the reason for voiding the PO.

Are you sure you want to **Void** this Purchase Order?

* Please enter the reason below:

Voiding the PO per department

yes **no**

- Click **yes**.

The system displays this window.

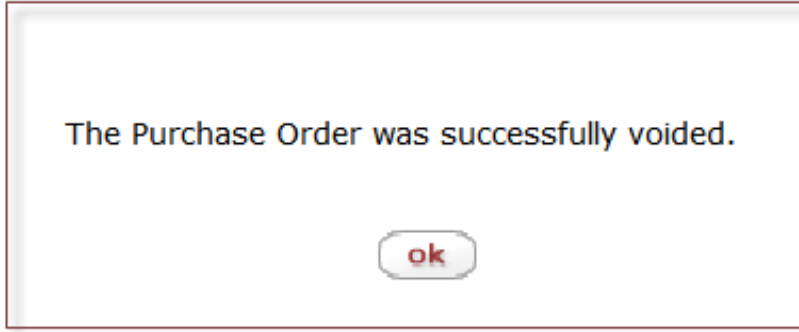

5. Click .

The system displays the OLE main menu.

Purchase Order Close

The Close Order (POC) document closes an open PO. When you close an order, all encumbrances associated with the remaining items are disencumbered. Items already paid are unaffected. This option should be used only when there are payment requests against the PO. You must enter a reason when initiating the PO close action.

Note

To close a PO without outstanding payment requests, use the **Void Order** option.

Document Layout

The document layout of the POC document is identical to that of the original PO, with an additional notation regarding the status in the Document Header. A notation also displays at the top of the PO document, such as 'Warning: There is a pending action on this Purchase Order.'

General Ledger Pending Entries Tab

When the POC document is successfully submitted, the **General Ledger Pending Entries** tab shows the transactions to disencumber remaining encumbrances on this PO.

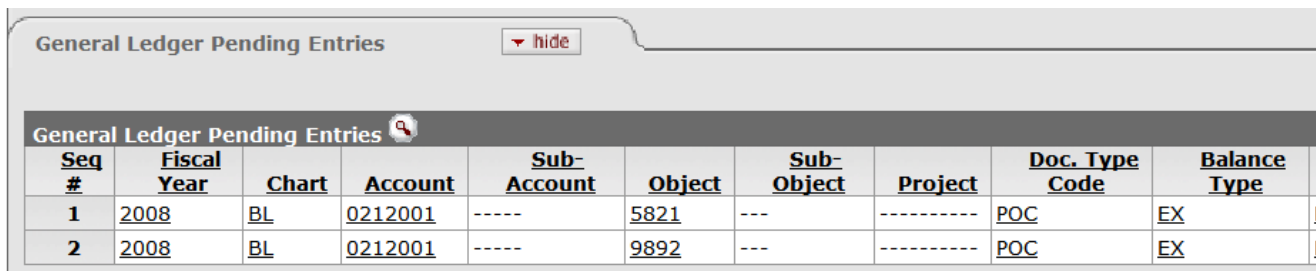

Seq #	Fiscal Year	Chart	Account	Sub-Account	Object	Sub-Object	Project	Doc. Type Code	Balance Type
1	2008	BL	0212001	-----	5821	---	-----	POC	EX
2	2008	BL	0212001	-----	9892	---	-----	POC	EX

Note

For information about the fields on this document, see “Document Layout” under [Purchase Order](#).

Notes and Attachments Tab

When you click the **close order** button, the system automatically inserts a note text into the **Notes and Attachments** tab of the original PO and the POC document.

Notes and Attachments (1) hide			
Notes and Attachments			
	<u>Posted Timestamp</u>	<u>Author</u>	<u>* Note Text</u>
add:			<input type="text"/>
1	09/26/2007 10:52 AM	HUNTLEY,KEISHA Y	Note entered while closing a Purchase Order : test

Process Overview

Business Rules

- There must be at least one outstanding payment request against to close the PO.
- The POC document generates General Ledger Pending Entries to disencumber remaining encumbrances on the PO.

Routing

- The document becomes 'FINAL' when the POC document is submitted.

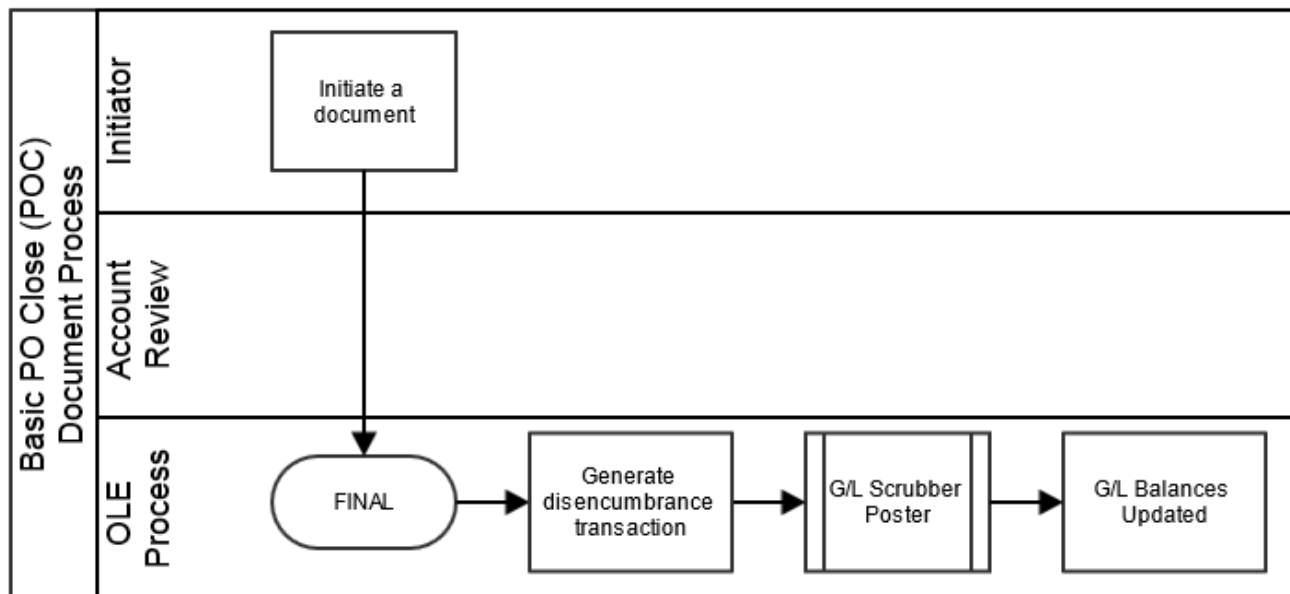

Initiating a PO Close Document

6. Search for a PO from the PO search screen and open the PO document you want to close.
7. Click  to close out any remaining items on the PO.

The system displays the OLE main menu.

Purchase Order Reopen

The Purchase Order Reopen (POR) document reopens the PO and re-encumbers any lines that were disencumbered when the PO was originally closed. You must enter a reason when initiating the PO reopen action.

Note

The **open order** button is available only on a closed PO.

Document Layout

The document layout of the POR document is identical to that of the original PO, with an additional notation regarding the status in the Document Header. A notation also displays at the top of the PO document, such as 'Warning: There is a pending action on this Purchase Order.'

General Ledger Pending Entries Tab

When the POR document is successfully submitted, the **General Ledger Pending Entries** tab shows the transactions and re-encumbers the PO amount that was originally disencumbered by the POC document.

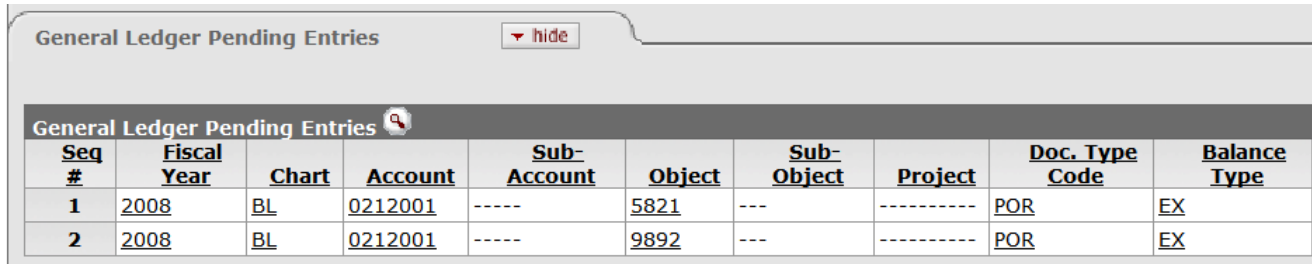

Seq #	Fiscal Year	Chart	Account	Sub-Account	Object	Sub-Object	Project	Doc. Type Code	Balance Type
1	2008	BL	0212001	----	5821	---	-----	POR	EX
2	2008	BL	0212001	----	9892	---	-----	POR	EX

Tip

Effect on an Account by the Purchase Order Reopen Document:When a POR document is submitted, the amount re-encumbered by the document is not the same as the original PO document. In the above example, the encumbered amount by the original PO was \$1,000. Then, the POC document disencumbered \$900. Finally, the POR document re-encumbered the amount disencumbered by the POC document. You may see the effect on the account from the General Ledger Pending Entries inquiry screen by

listing the transactions by the Reference Document Number that stores the PO number.

Fiscal Year	Chart Code	Account Number	Sub-Account Number	Object Code	Sub-Object Code	Balance Type Code	Object Type Code	Fiscal Period	Document Type Code	Origin Code	Document Number	Transaction Ledger Entry Description	Transaction Ledger Entry Amount	Debit Credit Code	Transaction Date
2008	BL	0212001	-----	5821	---	EX	EX	03	PO	EP			900.00	D	09/26/2007
2008	BL	0212001	-----	9892	---	EX	FB	03	PO	EP			900.00	C	09/26/2007
2008	BL	0212001	-----	5821	---	EX	EX	03	POC	EP			900.00	C	09/26/2007
2008	BL	0212001	-----	9892	---	EX	FB	03	POC	EP	316856	TP Generated Offset	900.00	D	09/26/2007
2008	BL	0212001	-----	5821	---	EX	EX	03	POR	EP			900.00	D	09/28/2007
2008	BL	0212001	-----	9892	---	EX	FB	03	POR	EP	317447	Generated Offset	900.00	C	09/28/2007

PO encumbers the original PO amount

POC disencumbers remaining encumbrances

POR reencumbers the disencumbered amount

Notes and Attachments Tab

When you click the **open order** button on the PO, the system automatically inserts note text into the **Notes and Attachment** tab of the original PO document and the POR document.

Notes and Attachments (2) hide

Warning: This includes all notes on the PO, not just up to this document.

Notes and Attachments			
	Posted Timestamp	Author	* Note Text
add:			
1	09/26/2007 10:52 AM	HUNTLEY,KEISHA Y	Note entered while closing a Purchase Order : test
2	09/28/2007 12:09 PM	PHILIPS,KRISTIN U	Note entered while reopening a Purchase Order : Service order still pending - reopen PO per Biology Department

Process Overview

Business Rules

- The POR may be initiated only from the closed PO.
- The POR document generates General Ledger Pending Entries to re-establish encumbrance to match the amount disencumbered by the POC document.

Routing

- The document becomes 'FINAL' when the POR document is submitted.

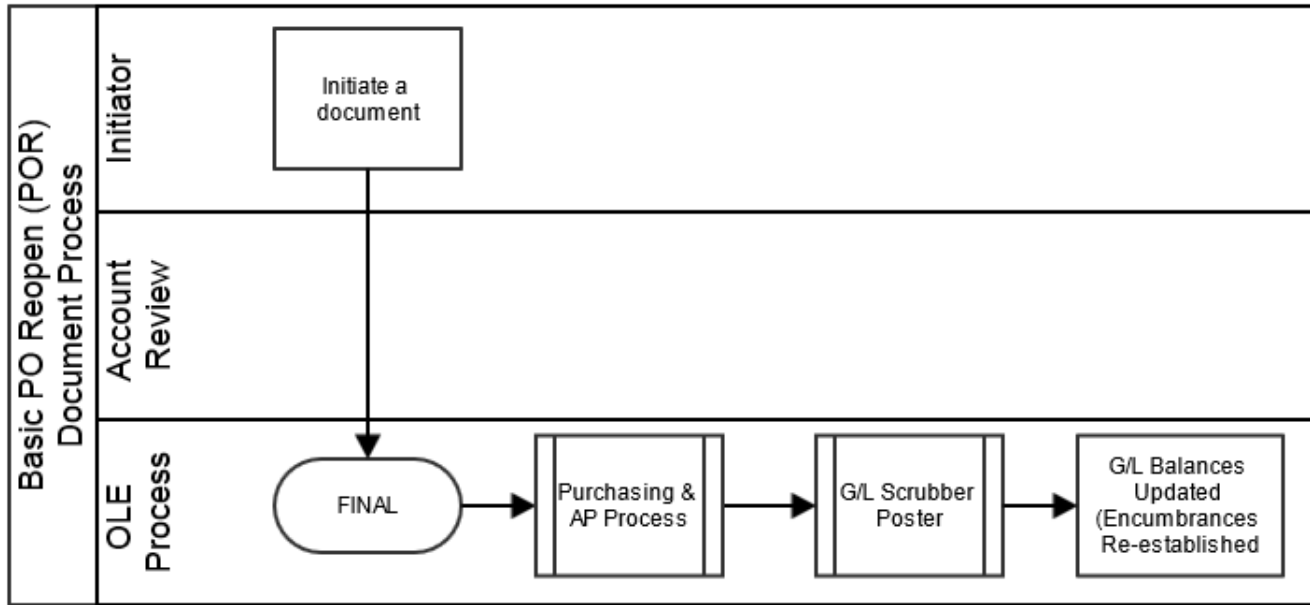

Initiating a Purchase Order Reopen Document

8. Search for the PO that you want to reopen from the PO search and open the PO.
9. Click to reopen the PO and re-encumber any lines that were disencumbered when the PO was originally closed.
10. Enter the reason for reopening the PO.

Are you sure you want to **Reopen** this Purchase Order?

* Please enter the reason below:

Service order still pending - reopen PO per Biology Department

11. Click .

The system displays this window.

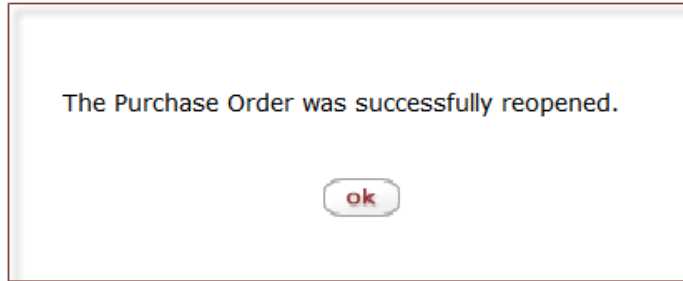

12. Click  .

The system displays the OLE main menu.

Order Holding Queue



The Order Holding Queue was designed to allow users a quick search interface that allowed some global actions:

- filter requisitions search - open or in process (not yet APO)
- **assign** requisitions to other selection or acquisitions staff
- use a **totals** tool to do simple pricing calculations on a group of selected requisitions
- **approve** a group of requisitions into the next workflow step (subject to user permissions and requisition business rules)
- **cancel requisitions** (or archive) that the user no longer wishes to purchase/convert to approved and transmitted purchase order (permissions based).

To view open or in-process Requisitions, click on the **Order Holdings Queue** link on the **Main Menu**.

You may **select** items on the left column of the search results. Continue to scroll to the bottom of the screen to **approve, cancel, assign** or **total**:

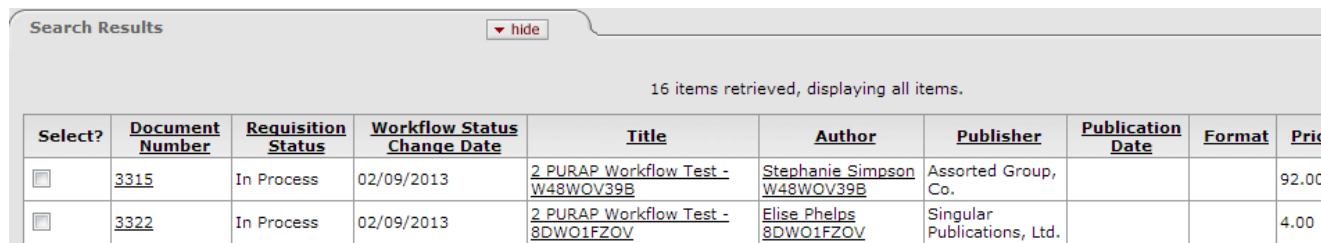

Search Results hide

16 items retrieved, displaying all items.

Select?	Document Number	Requisition Status	Workflow Status Change Date	Title	Author	Publisher	Publication Date	Format	Price
<input type="checkbox"/>	3315	In Process	02/09/2013	2 PURAP Workflow Test - W48WOV39B	Stephanie Simpson W48WOV39B	Assorted Group, Co.			92.00
<input type="checkbox"/>	3322	In Process	02/09/2013	2 PURAP Workflow Test - 8DWO1FZOV	Elise Phelos 8DWO1FZOV	Singular Publications, Ltd.			4.00

Ordering Materials: Standard
Transactional E-Docs

	4068	In Process	02/19/2013	The First Duke in Milan E3QY81BQQ	Elise Carmichael E3QY81BQQ	Singular Group Ltd.	1924	Book	94.00
--	------	------------	------------	------------------------------------------------------	-----------------------------------------------	---------------------	------	------	-------

[select all from all pages](#) [deselect all from all pages](#) [select all from this page](#) [deselect all from this page](#)

Assign To [hide](#)

Assign To

User Id

Actions [hide](#)

[approve](#) [cancel requisition](#) [assign](#) [total selected items](#)

The Order Holding Queue is simply a portal or view of open requisitions. These open requisitions will route according to requisitions business rules and workflow.

Note

For information about performing a search for one or more requisitions, see [Performing Acquisition Searches](#) on the *OLE E-Doc Fundamentals* wiki page.

Ordering Materials: Standard
Transactional E-Docs

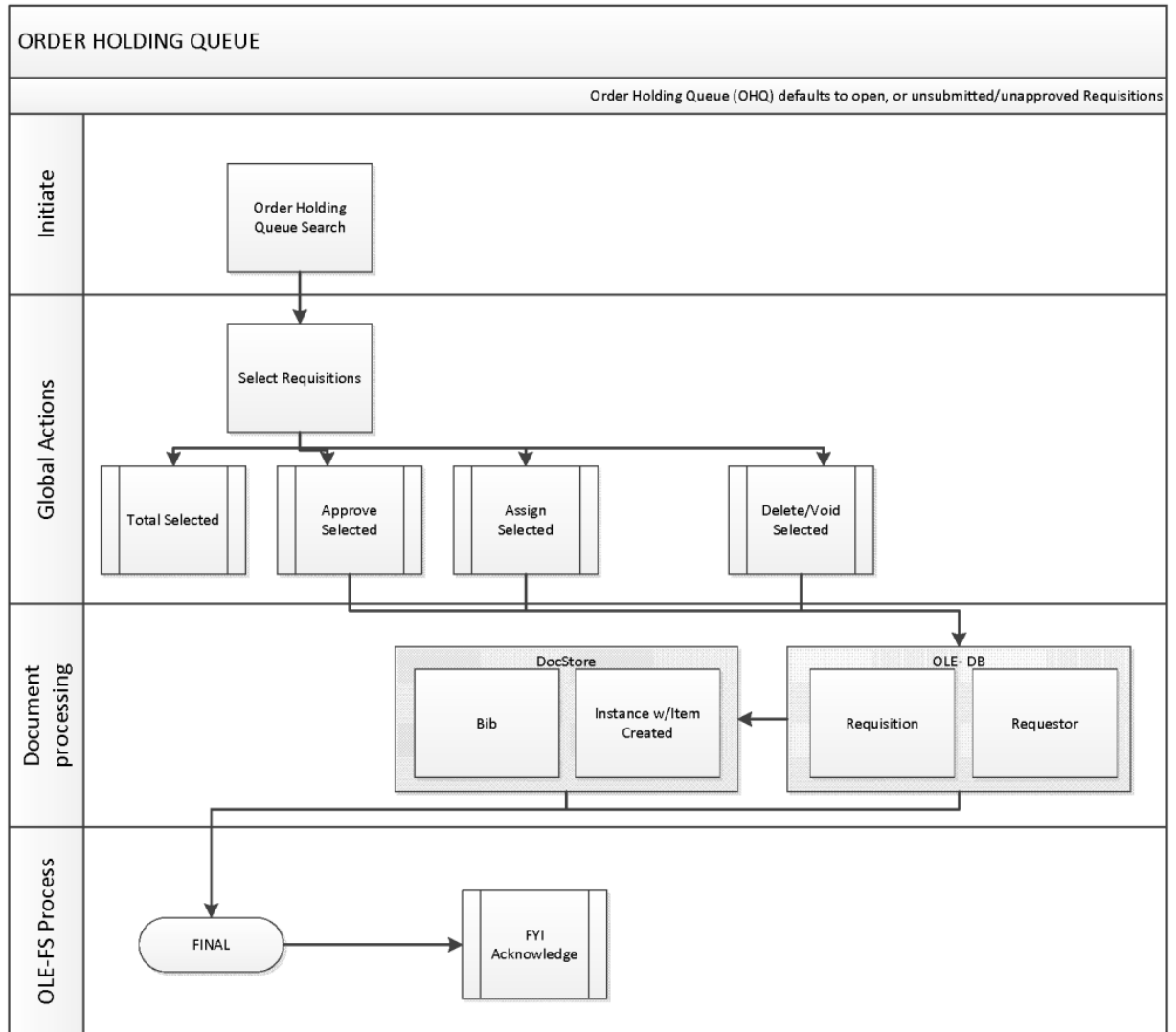

Chapter 4. Paying for Materials: Standard Transactional E-Docs

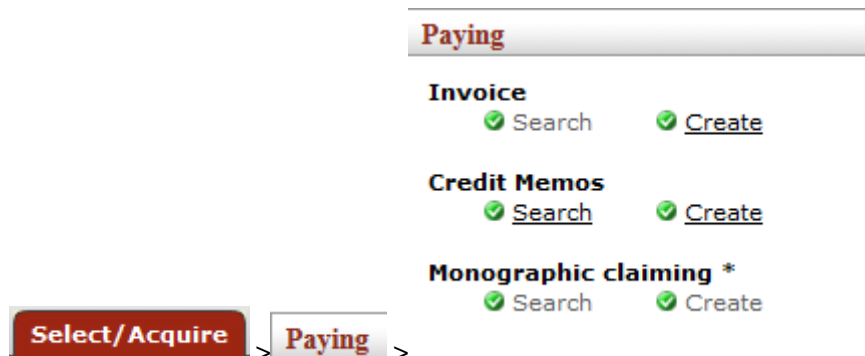

On the Select/Acquire tab, the Paying submenu provides access to invoices, credit memos and claiming e-documents.

Invoice Search



Warning

NOT YET AVAILABLE

OLE offers a customized document search related to invoices. The search screen contains the standard search fields along with special fields that are unique to this type of e-doc.

Note

For information about performing a search for one or more payment requests, see [Performing Acquisition Searches](#) on the *OLE E-Doc Fundamentals* wiki page.

Note

For information about Document lookup fields that are specific to payment requests, see “Document Layout” under [Invoice](#).

Invoice

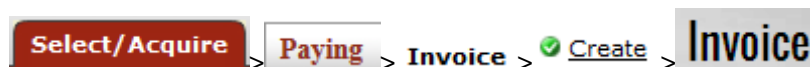

Getting Started

OLE 1.0 contains several roles for vendor invoicing.

Paying for Materials:
Standard Transactional E-Docs

To create unapproved invoicing and payment requests, please sign into OLE as:

Role	Login
Receiving-AQ3,	ole-durbin
Receiving-AQ4	ole-cstan; ole-earley
Accounting-AQ2, -AQ3, -AQ4	ole-cphovis; ole-durbin; ole-earley
Super user	ole-khuntley (can do all)

Note

For OLE 1.0, we have not yet coded full university financial integrations. To “stub” this functionality at present, and to simulate how general ledger, fund/account updates, and expenses might be approved and processed through the university financial system, all payment requests stop at the relevant Fiscal/Accounts staff for final routing/export/batch processing.

Role	Login
Fiscal officer	ole-rorenfro
Fiscal manager	ole-jaraujo

[hide](#)

Document Overview

* **Description:** PO: 1031 Vendor: YBP Library Services

Organization Document Number:

[hide](#)

Financial Document Detail

* **Year:** 2013

[hide](#)

Payment Request Detail

Receiving Required: No

Order Type: Firm, Fixed

Proforma:

[show](#)

Vendor

[hide](#)

Invoice Info

* **Invoice Number:** ABC123

Pay Date: 04/29/2013 (Immediate Pay)

* **Invoice Date:** 04/01/2013

PO End Date:

Payment Attachment Indicator:

Extract Date:

Invoice Type:

* **Bank Code:** TEST
FIRST NATIONAL TEST BANK OF KUALI

[hide](#)

Process Items

Purchase Order Line Item Totals

Encumbrance excluding freight & s/h	Total Encumbrance Amount Relieved
39.95	0.00

Process Titles

Add Item

Item Line #	Open Qty	PO Unit/Ext Price	Format	Vendor Item Identifier	* No of Copies Ordered	* No. of Parts	* List Price	* Discount	Dis
		<input type="text"/>	<input type="text"/>	<input type="text"/>	<input type="text"/>	<input type="text"/>	<input type="text"/>	<input type="text"/>	<input type="text"/>
Bib Info:	Bib Editor	<input type="button" value="create new"/>	Receipt Status	<input type="text"/>					

Current Items

Item Line #	Open Qty	PO Unit/Ext Price	Format	Vendor Item Identifier	* No of Copies Ordered	* No. of Parts	List Price	Discount	Dis
1	1	39.9500			<input type="text"/>	<input type="text"/>	<input type="text"/>	<input type="text"/>	<input type="text"/>
1	Bib Info:	Bib Editor	<input type="button" value="edit"/>	Receipt Status	<input type="text"/>				

Invoice Notes

Accounting Lines

Invoice Total Prior to Additional Charges:	39.95
Additional Charges <input type="button" value="show"/>	
Grand Total:	39.95 <input type="checkbox"/> Close PO

Account Summary

View Related Documents

View Payment History

General Ledger Pending Entries

Notes and Attachments (0)

Ad Hoc Recipients

Route Log

This screen includes unique **Document Overview**, **Vendor**, **Invoice Info**, **Process Items**, **Account Summary** tabs in addition to the standard tabs that display at the bottom of a financial transaction document.

Note

For more information about the standard tabs, see [Standard Tabs](#) on the *OLE E-Docs fundamentals* wiki page.

Document Overview Tab

The screenshot shows a software interface with a dark header bar containing a dropdown arrow and the text 'Document Overview'. Below this is a light gray bar with the text 'Document Overview'. The main area contains a table with three columns. The first column has two rows: '* Description:' with a text input field containing 'New Invoice Document', and 'Organization Document Number:' with an empty text input field. The second column is empty. The third column has a header 'Explanation:' and an empty text input field. Below this table is another dark header bar with the text 'Financial Document Detail'. Underneath, there is a row with 'University Fiscal Year:' followed by a text input field containing '2014'.

Note

For information about the standard Document Overview tab, see [Standard Tabs](#) on the *OLE E-Docs fundamentals* wiki page.

Financial Document Detail Section

Financial Document Detail section definition

Title	Description
Year	Display-only. The fiscal year of the purchase order referenced by the Payment Request document.
Total Amount	Display-only. The total amount of the payment request after the request has been submitted.

Vendor Tab

▼ Vendor Info		
Vendor Address		
* Suggested Vendor:	<input type="text"/>	City:
Vendor #:	<input type="text"/>	State:
Address 1:	<input type="text"/>	Province:
Address 2:	<input type="text"/>	Postal Code:
Attention:	<input type="text"/>	Country:
Vendor Info		
Acquisition Unit's Vendor account / Vendor Info Customer # :	<input type="text"/>	Payment Terms:
	<input type="text"/>	Shipping Title :
Check Stub Notes:	<input type="text"/>	Shipping Payment Terms :
	<input type="text"/>	
Special Handling Instructions:	<input type="text"/>	
	<input type="text"/>	

The **Vendor** tab has two sections: **Vendor Address** and **Vendor Info**.

Vendor Address Section

Vendor Address section definition

Title	Description
Suggested Vendor	Select a vendor from the dropdown list, this will autopopulate the vendor address and some of the details in the vendor info tab.
Vendor Number	Display-only. Populates when the vendor is selected from the Suggested Vendor dropdown. The vendor number followed by a hyphen and the division number.
Address 1	Display-only. Populates when the vendor is selected from the Suggested Vendor dropdown.
Address 2	Display-only. Populates as necessary when the vendor is selected from the Suggested Vendor dropdown.
Attention	Display-only. Populates as necessary when the vendor is selected from the Suggested Vendor dropdown.
City	Display-only. Populates when the vendor is selected from the Suggested Vendor dropdown.
State	Display-only. Populates when the vendor is selected from the Suggested Vendor dropdown.
Province	Display-only. Populates as necessary when the vendor is selected from the Suggested Vendor dropdown.
Postal Code	Display-only. Populates when the vendor is selected from the Suggested Vendor dropdown.
Country	Display-only. Populates when the vendor is selected from the Suggested Vendor dropdown.

Vendor Info Section

Vendor Info section definition

Title	Description
-------	-------------



Paying for Materials:
Standard Transational E-Docs

Acquisition Unit's Vendor Account/ Vendor Info Customer #	Optional. Populated from the PO. Override it by entering the customer number directly.
Check Stub Notes	Optional. Enter text to be printed on the check stub. This three line field allows for special notes to be printed on the check stub for the payment. Please note that entering a value into this field will force the system to create a physical check rather than an ACH transfer.
Special Handling Instructions	Optional. Enter the handling instructions to be printed on the check. These handling instructions relate to the delivery of the check to the vendor. Please note that entering a value into this field will force the system to create a physical check rather than an ACH transfer.
Payment Terms	Populates when the vendor is selected from the Suggested Vendor dropdown. Override it by selecting a different payment term from the dropdown list.
Shipping Title	Display-only. Populates when the vendor is selected from the Suggested Vendor dropdown.
Shipping Payment Terms	Display-only. Populates as needed when the vendor is selected from the Suggested Vendor dropdown.

Invoice Info Tab

Invoice Info	
Invoice Number:	<input type="text"/>
Payment Classification:	<input type="text"/>
* Vendor Invoice Amount:	<input type="text"/>
Extract Date:	<input type="text"/>
Invoice Type:	<input type="text" value=""/>
Bank Code:	<input type="text"/>
Pay Date:	<input type="text"/>
* Invoice Date:	<input type="text"/>
Payment Attachment Indicator?:	<input type="checkbox"/>
Processed Date:	<input type="text"/>
Invoice Sub-Type:	<input type="text" value=""/>
* Payment Method:	<input type="text"/>

Invoice Info tab definition

Title	Description
Invoice Number	
Payment Classification	Display-only. Not currently used. In Kuali OLE the field will always be null. In a future enhancement, when wire transfer and foreign drafts are processed on Payment Request documents, this field will be populated.
Vendor Invoice Amount	Display-only. The vendor total invoice amount as entered on the Payment Request Initiation tab. This field is displayed only on an 'In Process' PREQ document. When the document is submitted, the system no longer carries the field and the value forward.
Extract Date	Display-only. The date the Payment record is extracted to the Pre-Disbursement Processor.
Invoice Type	Optional. Select the type of invoice. Sample data values are Proforma/ prepay, Regular.
Bank Code	Required. The bank code will be displayed only if the Bank_Code_Document_Types includes 'PREQ' and Enable_Bank_Specification_Ind='Y'. The default bank is determined by the Default_Bank_By_Document_Type parameter. You may override this value by entering another bank code or selecting it from the Bank lookup  .
Pay Date	Defaults to the date automatically calculated by the system. If payment terms are edited, the system repopulates this field only if it is blank. Override the automatic entry by entering a pay date or selecting it from the calendar  .
	<p>Note</p> <p>Pay Date Calculations: The pay date is calculated automatically as follows. The payment terms specified</p>

Paying for Materials:
Standard Transational E-Docs

	are applied to the invoice date to generate a pay date. The payment terms parameters are in the Payment Terms Type table. Additionally, ten days (or another institutionally defined default number of days) are added to the current date to generate a pay date. KUALI OLE selects the later of these two dates and uses it as the default pay date for this Payment Request document.
	The pay date may be entered manually, but it must not be a past date. If the date is more than 60 days from the current date, the system displays a warning message.
(Immediate Payment Indicator)	Optional. Select the Immediate Pay check box if a check is needed on the same day (overrides the pay date – subject to the rules of your accounts-payable system). This indicator allows for an approved payment request to be extracted for payment during the day.
Invoice Date	Enter an invoice date or select it from the calendar 
Payment Attachment Indicator	Optional. Select the check box if an attachment (such as a copy of the invoice) must be returned to the Vendor with this payment.
Processed Date	
Invoice Sub Type	Select the invoice sub type from the drop down menu.
Payment Method	Select the method of payment from the drop down menu.

Process Items Tab

Process Items

Purchase Order : 

Process Titles

Purchase Order Documents

Invoice Total Prior to Additional Charges:

Additional Charges

Item Type	Extended Cost
Freight	<input type="text"/>
Accounting Lines	
Shipping and Handling	<input type="text"/>
Accounting Lines	
Minimum Order	<input type="text"/>
Accounting Lines	
Miscellaneous or Overhead	<input type="text"/>
Accounting Lines	

Grand Total: \$0.00

The **Process Items** tab includes a **Purchase Order** field and two additional sections: **Process Titles**, and **Additional Charges**.

Purchase Order

Process Titles

Additional Charges

The Additional Charges tab allows lines for predetermined charges to be included on the payment request. This tab is divided into four charge lines, each representing a different type of charge, each with its own accounting lines, and a series of options through which the amounts added in this section can be prorated to the existing line items in the Current Items sub tab. The four Additional Charges lines are **Freight**, **Shipping and Handling**, **Minimum Order**, and **Miscellaneous or Overhead**.

Additional Charges	
Item Type	Extended Cost
Freight	<input type="text"/>
Accounting Lines	
Shipping and Handling	<input type="text"/>
Accounting Lines	
Minimum Order	<input type="text"/>
Accounting Lines	
Miscellaneous or Overhead	<input type="text"/>
Accounting Lines	

Additional Charges section definition

Title	Description
Item Type	Display-only. The type of item to be charged.
Foreign Currency Extended Cost	Displays the extended amount charged on the invoice for this additional charge item.
Currency Type	Display only. Identifies the associated vendor's currency as identified on the vendor record that is identified in the Link to Vendor/Supplier
Extended Cost	Displays the extended amount charged on the invoice for this additional charge item.
Description	Required for miscellaneous charges. A description is optional for freight charges, shipping and handling, and minimum order charges. <p style="text-align: center;">Note</p> <p>The ITEM_TYPES_REQUIRING_USER_ENTERED_DESCRIPTION parameter controls whether the description is required or optional.</p>

If you choose, you may also prorate the additional charges to the invoiced titles.

Enter the amount of the additional charge, select to prorate by **Quantity**, **Dollar**, or **Manual Prorate**. If Manual prorate is selected, enter the amount you would like prorated to each title.

Modifying the Process Items Tab

Account Summary Tab

The Account Summary tab will summarize all accounts attached to the payment request and their respective charges after calculation. Information in the account summary is divided first by account, then by line item or additional charges line. Charges prorated to multiple accounts will be represented separately. Any changes made to accounting line items will not be updated until the PREQ has been calculated and the "Refresh Account Summary" button at the top of the tab has been clicked.

Click **refresh account summary** to reload the page and view all the fiscal years, accounting lines and dollar amounts for this requisition.

Process Overview

Business Rules

.

Routing

Vendor Credit Memo Search

Select/Acquire > **Paying** > **Credit Memos** >  [Search](#)

OLE offers a customized document search related to credit memos. The search screen contains the standard search fields along with special fields that are unique to this type of e-doc.

Note

For information about performing a search for one or more credit memos, see [Performing Acquisition Searches](#) on the *OLE E-Doc Fundamentals* wiki page.

Note

For information about Document lookup fields that are specific to credit memos, see “Document Layout” under [Vendor Credit Memo](#).

Vendor Credit Memo

Select/Acquire > **Paying** > **Credit Memos** >  [Create](#) > **Vendor Credit Memo**

The Vendor Credit Memo (CM) document allows you to process vendor refunds for goods or services related to invoices processed on POs. You may process a vendor credit memo against a specific payment request, a purchase order, or a vendor ID.

Note

You must be a member of the role OLE-SELECT Accounting-AQ2, -AQ3 or -AQ4 to initiate the Vendor Credit Memo document.

Document Layout

Two screens are associated with this e-doc—an initiation screen with a single folder, followed by a main screen with multiple folder tabs.

Credit Memo Initiation Tab

When you select **Vendor Credit Memo** from the main menu, the system displays the **Credit Memo Initiation** tab.

Credit Memo Initiation		
* Credit Memo # from Vendor:	1200-BN-1090-1	**Payment Request
* Credit Memo Date:	07/22/2009	**Purchase Order
* Vendor Credit Memo Amount:	14	**Vendor

** You must enter one and only one of these fields: Payment R

This tab is used to specify the vendor credit memo number, date, and amount for the credit memo along with the number for a payment request, a purchase order, or a vendor in order to initiate the Vendor Credit Memo document.

Credit Memo Initiation tab definition

Title	Description
Credit Memo # from Vendor	Required. Enter the number found on the vendor's credit memo.
Credit Memo Date	Required. Enter the date found on the credit memo itself or select the date from the calendar .
Vendor Credit Memo Amount	Required. Enter the net amount of the credit.
Payment Request #	Specify a payment request number in this field <i>only</i> if the vendor credit memo is processed against a specific payment request. See note below.
Purchase Order #	Specify a PO number in this field <i>only</i> if the vendor credit memo is processed against a specific PO. See note below.
Vendor #	Specify a vendor number in this field <i>only</i> if the vendor credit memo is general in nature (not applicable to a specific payment request or a specific PO). See note below.

Note

An entry in one and only one of these three fields is required: **Payment Request #**, **Purchase Order #**, or **Vendor #**.

Click  to begin initiation of this vendor credit memo.

The Vendor Credit Memo document continues from the initiation screen to the main document screen that displays the unique **Vendor**, **Credit Memo Info**, and **Process Items** tabs in addition to the standard e-doc tabs.

Paying for Materials:
Standard Transational E-Docs

Vendor Credit Memo ?	Doc Nbr: 3343	S
	Initiator: ole-khuntlev	Cre
	Vendor Credit Memo #: 1003	Vendor Credit Memo Doc S

Document Overview ▼ hide

Document Overview

* Description: PO: 1007 Vendor: D.K. Agencies (P) Ltd. Explanation:

Organization Document Number:

Financial Document Detail

* Year: 2013 Total Amount: 0

Vendor Credit Memo Document Detail

Order Type: Firm, Fixed ▼

Vendor ▶ show

Credit Memo Info ▼ hide

Credit Memo Info

* Credit Memo # from Vendor:	12345	Credit Memo Type:	PO
* Credit Memo Date:	05/27/2013	Vendor #:	1009-0
* Vendor Credit Memo Amount:	25.00	Purchase Order #:	1007
PO End Date:		Payment Request #:	
PO Notes:	No	AP Processed Date:	
Extract Date:		Credit SubType:	
Credit Type:	<input type="text"/>	* Payment Method:	<input type="text"/>
* Bank Code:	TEST FIRST NATIONAL TEST BANK OF KUALI		

Process Items ▼ hide

Process Titles

Add Item



#	PO Qty	PO Unit Price	Total Invoice Cost	CM Qty	CM Unit Price	Prorated Surcharge	Credit Processed	Catalog #	Description
	<input type="text" value="1.00"/>	<input type="text" value="0"/>		<input type="text" value="1.00"/>			<input type="text"/>		
Foreign Currency Conversion									
	Currency Type		* Foreign List Price	Foreign Discount	Discount Type		Foreign Discount Amt	Foreign Unit Cost	Exchange
	Indian Rupee		<input type="text"/>	<input type="text" value="0.00"/>	<input style="border: 1px solid black;" type="text" value="%"/>				
Bib Info:	Bib Editor	<input type="button" value="create new"/>							
Current Items									
#	PO Qty	PO Unit Price	Total Invoice Cost	CM Qty	CM Unit Price	Prorated Surcharge	Credit Processed	Catalog #	Description
	1.00	50.72	50.72	<input type="text" value="1.00"/>	50.72	0	<input type="text"/>		Oh, the Places Yo Go!
Foreign Currency Conversion									
	Currency Type		* Foreign List Price	Foreign Discount	Discount Type		Foreign Discount Amt	Foreign Unit Cost	Exchange
	Indian Rupee		<input type="text" value="2,500.00"/>	<input type="text" value="0.00"/>	<input style="border: 1px solid black;" type="text" value="%"/>		0.00	2,500.00	49.29
Bib Info:	Bib Editor	<input type="button" value="edit"/>							
▶ show Accounting Lines									
Total credit processed prior to restocking fee: 0.00									
Additional Charges ▶ show									
Grand Total:									

Note

For information about the standard tabs, see [Standard Tabs](#) on the *OLE E-Doc Fundamentals* wiki page.



Vendor Tab

The **Vendor** tab allows you to modify the vendor address information via address lookup if the credit memo has been processed against a PO or a vendor. You may also add check stub notes on this tab.

Vendor	
hide	
Vendor Address	
* Vendor:	YBP Library Services
Vendor #:	12106-0
* Address 1:	P.O. BOX 277991 
Address 2:	
Attention:	
* City:	Atlanta
State:	GA
Province:	
Postal Code:	30384-7991
* Country:	United States
Vendor Info	
Acquisition Unit's Vendor account / Vendor Info Customer # :	
Check Stub Notes:	<input type="text"/> <input type="text"/> <input type="text"/>

This tab contains two sections, **Vendor Address** and **Vendor Info**.

Vendor Address section definition

Title	Description
Vendor	Display-only. The name of the vendor.
Vendor #	Display-only. The number that uniquely identifies the particular vendor.
Address 1	Required. The first line of the vendor's address. A change of address is possible via lookup  for credits processed referencing the PO or referencing the vendor. Note The lookup is not provided if a payment request number was entered in the Credit Memo Initiation tab Leave as is or search for the address from the Address lookup  .
Address 2	Display-only. The second line of the vendor address.
Attention	Display-only. If the credit memo is against a payment request and the payment request had an attention line completed, the name in the attention line on the payment request populates this field.
City	Display-only. The city of the vendor's address.
State	Display-only. The state of the vendor's address.
Province	Display-only. The province of the vendor's address (foreign addresses).
Postal Code	Display-only. The postal code of the vendor's address.
Country	Display-only. The country of the vendor's address.

Vendor Info Section

Vendor Info section definition

Title	Description
-------	-------------



Paying for Materials:
Standard Transational E-Docs

Acquisition Unit's Vendor account / Vendor Info Customer #	Display-only. The ID number for the customer. The system displays this value if a customer number exists on the referenced document. A change of customer number is possible via lookup  for credits processed referencing the PO or the vendor. <p style="text-align: center;">Note</p> The lookup is not provided if a payment request number was entered in the Credit Memo Initiation tab.
Check Stub Notes	Optional. Enter text to be printed on the check stub.



Credit Memo Info Tab

The **Credit Memo Info** tab displays information pertinent to the current credit memo. In the examples below, the first credit memo is against a payment request and the second is against a vendor.

Credit Memo Info ▼ hide

Credit Memo Info	
* Credit Memo # from Vendor:	12321
* Credit Memo Date:	05/06/2013
* Vendor Credit Memo Amount:	91.00
PO End Date:	
PO Notes:	No
Extract Date:	
Credit Type:	<input type="text"/> 
* Bank Code	TEST  FIRST NATIONAL TEST BANK OF KUALI

Credit Memo Info tab definition

Title	Description
Credit Memo # from Vendor	Display-only. The credit memo number as entered on the Credit Memo Initiation tab.
Credit Memo Date	Display-only. The credit memo date as entered on the Credit Memo Initiation tab.
Vendor Credit Memo Amount	Display-only. The amount of the credit as entered on the Credit Memo Initiation tab. This field is displayed only on an in-process Vendor Credit Memo document. After the document has been submitted, the field no longer carries forward.
PO End Date	Display-only. The end date automatically populated from PO information.
PO Notes	Display-only. 'Yes' if the PO contains notes.
Extract Date	Display-only. The date the credit record was extracted to the Pre-Disbursement Processor.
Credit Type	Corresponds to the Invoice Type on Payment Requests. Enter a value or search from the lookup  .
Bank Code	Required. The bank code will be displayed only if the Bank_Code_Document_Types includes 'CM' and Enable_Bank_Specification_Ind='Y.' The default bank is determined by the Default_Bank_By_Document_Type parameter. You may override this value by entering another bank code or selecting it from the Bank lookup  .
Credit Memo Type	Display-only. Indicates whether this credit memo references a payment request, PO, or vendor.
Vendor #	Display-only. Automatically populated based on the entry in the Credit Memo Initiation tab that references either the payment request, the

Paying for Materials:
Standard Transactional E-Docs

	purchase order or the vendor number. The vendor number is followed by a hyphen and the division number.
Purchase Order #	Display-only. The referenced purchase order number or the purchase order number associated with the referenced payment request.
Payment Request #	Display-only. If processing a credit against a payment request, this field is populated based on the entry in the Credit Memo Initiation tab.
AP Processed Date	Display-only. The date the vendor credit memo was submitted by Accounts Payable.
Credit Sub Type	Corresponds to the Invoice Sub Type of the payment request. Example values may include "regular" and "supplemental". Enter a value or search from the lookup  .
Payment Method	Select the method of payment from the drop down menu.

Process Items Tab

The **Process Items** tab identifies the lines of a specified purchase order or payment request that this credit relates to. It also indicates the dollar amounts to be credited to individual lines and allows you to edit the accounting information associated with these lines. It also allows you to enter additional credits pertaining to items such as restocking fees or miscellaneous credits.

The tab includes two sections: **Items** and **Additional Charges**. In the example below, the credit references a purchase order.

▼ hide

Process Items

Process Titles

Add Item

#	PO Qty	PO Unit Price	Total Invoice Cost	CM Qty	CM Unit Price	Prorated Surcharge	Credit Processed	Catalog #
	<input type="text" value="1.00"/>	<input type="text" value="0"/>		<input type="text" value="1.00"/>	<input type="text"/>		<input type="text" value="0.00"/>	

Bib Info: **Bib Editor**

Current Items

#	PO Qty	PO Unit Price	Total Invoice Cost	CM Qty	CM Unit Price	Prorated Surcharge	Credit Processed	Catalog #	
1	1.00	44.00	44.00	<input type="text"/>	<input type="text" value="44.00"/>		<input type="text"/>		
Bib Info:		Bib Editor	<input type="button" value="edit"/>						
<input type="button" value="show"/>		Accounting Lines							
2	1.00	47.00	47.00	<input type="text"/>	<input type="text" value="47.00"/>		<input type="text"/>		
Bib Info:		Bib Editor	<input type="button" value="edit"/>						
<input type="button" value="show"/>		Accounting Lines							

Total credit processed prior to restocking fee:							0.00	
Additional Charges		<input type="button" value="show"/>						
Grand Total:							0.00	

Items Section

The makeup of the **Items** section varies based on whether the credit is being applied to a purchase order, payment request or vendor. If crediting by vendor, the **Items** section contains no fields. See below for the section definition when the CM is based on a vendor number or a payment request.

Process Items tab definition (credit references a purchase order)

Title	Description
-------	-------------

Paying for Materials:
Standard Transational E-Docs

#	Display-only. The item line number from the PO.
PO Qty	Display-only. The quantity of items available for credit.
PO Unit Price	Display-only. The unit price copied from the PO for this line item.
Total Invoice Cost	Display-only. The total amount already invoiced and available to credit for this line item.
CM Qty	Optional. Enter the number of items for this line that are to be credited. This entry increases the Open Qty value for this line item on the PO.
CM Unit Price	Optional. The unit price for this line item to be processed as a credit. This field is automatically populated using the price from the PO, but it may be edited to match the credit memo unit price.
Prorated Surcharge	Additional charge applied to the line item based on the proportional distribution.
Credit Processed	If blank and if the credit memo quantity invoiced is populated, the system calculates the credit processed for this line item when you click the calculate button. Note If the field already contains a value, you must delete the value in order to populate a new value by clicking calculate . Override the amount as needed.
Total Amount	Display-only. The sum of credit processed, if applicable.
Catalog #	Display-only. The catalog number for this item on the PO.
Description	Display-only. The description for this item on the PO.

In this next example, the credit references a payment request.

Process Items ▼ hide							
Process Titles							
Items							
#	PREQ Qty Invoiced	PREQ Unit Price	Total Invoice Cost	CM Qty	CM Unit Price	Prorated Surcharge	Credit Processed
1	1.00	80.00	80.00	<input type="text"/>	<input type="text" value="80.00"/>		<input type="text"/>
▶ show Accounting Lines							
2	1.00	71.00	71.00	<input type="text"/>	<input type="text" value="71.00"/>		<input type="text"/>
▶ show Accounting Lines							
Total credit processed prior to restocking fee:							0.00
Additional Charges ▶ show							
Grand Total:							0.00

Process Items tab definition (credit references a payment request)

Title	Description
#	Display-only. The item line number from the payment request.
PREQ Qty Invoiced	Display-only. The quantity of items available to be credited on the specified Payment Request document.

Paying for Materials:
Standard Transactional E-Docs

PREQ Unit Price	Display-only. The unit price copied from the payment request for this line item.
Total Invoice Cost	Display-only. The total amount available to be credited for this line item on the specified Payment Request document.
CM Qty	Optional. Enter the number of items for this line that are to be credited. This increases the Open Qty value for this line item on the PO.
CM Unit Price	Optional. The unit price for this line item to be processed as a credit. This field is automatically populated using the price from the payment request, but the unit price may be edited if the credit reflects a different price.
Prorated Surcharge	Additional charge applied to the line item based on the proportional distribution.
Credit Processed	If blank and if the credit memo quantity invoiced is populated, the system calculates the credit processed for this line item when you click the calculate button. Note If the field already contains a value, you must delete the value in order to populate a new value upon next calculate. Override the amount as needed.
Total Amount	Display-only. The sum of credit processed.
Catalog #	Display-only. The catalog number for this item on the PO.
Description	Display-only. The description for this item on the PO.

Additional Charges Section

Additional Charges section definition (credit references a payment request)

Title	Description
Item Type	Display-only. The type of item to be charged. Note An entry of 'Less Restocking Fee' reduces the amount of any credit entered for other item types.
Credit Processed	Optional. Enter the amount that corresponds to this item type. Note A 'Miscellaneous Credit' entry can be entered as a positive or negative amount if the parameter allows this choice. A positive amount increases the credit total.
Total Amount	Display-only. The sum of credit processed.
Description	Parameters control whether descriptions are required.

You may also prorate the additional charges to the invoiced titles. Enter the amount of the additional charge, select to prorate by **Quantity**, **Dollar**, or **Manual Prorate**. If Manual prorate is selected, enter the amount you would like prorated to each title.

For a vendor credit memo referencing a vendor ID, additional charges are the only types of information displayed in the **Process Items** tab. Dollar amounts are not prefilled, so you must enter accounting information.

In the example below, the credit references a vendor number.

Paying for Materials:
Standard Transactional E-Docs

Process Items ▼ hide

Total credit processed prior to restocking fee:		0.00
Additional Charges ▼ hide		
* Item Type	Credit Processed	
Less Restocking Fee		
	Less Restocking Fee :	<input type="text"/>
▶ show Accounting Lines		
Miscellaneous Credit		
	Miscellaneous Credit :	<input type="text"/>
▶ show Accounting Lines		
Grand Total:		0.00

This section presents information about restocking fees and miscellaneous credits that apply to the credit memo.

Additional Charges section definition (credit references a vendor number)

Title	Description
Credit Processed	The dollar amount to be applied to this vendor credit memo.
Total Amount	Display-only. The sum of credit processed, if applicable.
Description	Required by default for miscellaneous credit only.

Note

The Item_Types_Requiring_User_Entered_Description parameter controls whether the description is required or optional.

Note

Click **show/hide** to display or hide item accounting lines for each line item or additional item.

Item Accounting Lines ▼ hide

Accounting Lines hide detail									
Source									
	* Chart	* Account	Sub-Account	* Object	Sub-Object	Project	Org Ref Id	* Percent	Actions
add:	<input type="text"/>	<input type="text"/>	<input type="text"/>	<input type="text"/>	<input type="text"/>	<input type="text"/>	<input type="text"/>	<input type="text"/>	<input type="button" value="add"/>
1:	BL BLOOMINGTON	1031400 PSYCHOLOGY		5000 SUPPLIES AND EXPENSE				100	<input type="button" value="delete"/> <input type="button" value="bal inquiry"/>

View Related Documents Tab

The **View Related Documents** tab collects information about Purchasing/AP documents related to this Vendor Credit Memo document. For example, it displays identifying information and any pertinent notes for the requisition, purchase order, receiving documents, payment requests, or other vendor credit memos associated with the purchase order.

Paying for Materials:
Standard Transational E-Docs

View Related Documents	
hide	
Related Documents	
Requisition - 1059	No Notes
Purchase Order - 1063	No Notes
Payment Request - 1068	No Notes
Payment Request - 1067	No Notes

This tab lists related documents.

View Related Documents tab definition

Title	Description
Date	Display-only. The date the related document was created.
User	Display-only. The user who created the related document. Entry of 'Kuali System User' means the document was automatically created by the system.
Note	Display-only. A note describing the document.

To access one of these related documents, click its document number. The system displays the document in a separate window.

View Payment History Tab

The **View Payment History** tab tracks payment information related to the purchase order associated with this Vendor Credit Memo document. It shows pending payment information and updates indicating when a payment was processed through the Pre-Disbursement Processor (PDP). This tab also shows any other vendor credit memos that have been processed against the related purchase order and any associated payment requests.

View Payment History										
hide										
Payment History - Payment Requests										
PREQ #	Invoice #	PO #	PREQ Status	Hold	Request Cancel	Vendor Name	Customer #	Amount	Pay Date	
1068	I-2	1063	Auto-Approved	No	No	DIVISION 1 OF PO BASIC		221.00	10/26/2009	2009-10-26
1067	I-1	1063	Department-Approved	No	No	DIVISION 1 OF PO BASIC		294.00	10/26/2009	2009-10-26
Payment History - Credit Memos										
CM #	Vendor CM #	PREQ #	PO #	Credit Memo Status	Hold	Vendor Name	Customer #	Amount	APAD Date	
1003	I-C-1	1067	1063	Complete	No	DIVISION 1 OF PO BASIC		100.00	10/26/2009	2009-10-26

Payment Requests section definition

Title	Description
PREQ#	Display-only. The payment request number.
Invoice #	Display-only. The invoice number.
PO#	Display-only. The purchase order number.
PREQ Status	Display-only. The payment request status.
Hold	Display-only. Displays 'yes' if the payment request in on hold. Displays 'no' if the payment request is not on hold.

Paying for Materials:
Standard Transational E-Docs

Req Canc	Display-only. Displays 'yes' if the payment request has been requested to be canceled. Displays 'no' if the payment request has not been requested to be canceled or if the 'request cancel' has been removed.
Vendor Name	Display-only. The vendor name associated with this payment request.
Customer #	Display-only. The customer number associated with this payment request.
Amount	Display-only. The payment request amount.
Pay Date	Display-only. The date the payment is scheduled to extract to PDP.
PDP Extract Date	Display-only. The date the payment request was extracted to the Pre-Disbursement Processor for disbursement processing.
Paid?	Display-only. Displays 'yes' if the payment has been disbursed. Displays 'no' if the payment has not been disbursed.

Credit Memos section definition

Title	Description
CM#	Display-only. The credit memo number assigned by OLE.
Vendor CM#	Display-only. The credit memo number assigned by the vendor.
PREQ#	Display-only. The payment request number, if a payment request was referenced in processing the credit memo.
PO#	Display-only. The purchase order number associated with this credit memo.
Credit Memo Status	Display-only. The credit memo status.
Hold	Display-only. Displays 'yes' if the credit memo is on hold. Displays 'no' if it is not on hold.
Vendor Name	Display-only. The vendor name associated with this credit memo.
Customer #	Display-only. The customer number associated with this credit memo.
Amount	Display-only. The dollar amount associated with this credit memo.
APAD Date	Display-only. The Accounts Payable approved date (that is, the date the Accounts Payable User submitted the credit memo).
PDP Extract Date	Display-only. The date the credit memo was extracted to the Pre-Disbursement Processor for disbursement processing.
Paid?	Display-only. Displays 'yes' if the credit has been disbursed. Displays 'no' if it has not been disbursed.

Process Overview

Business Rules

- If the vendor number and credit memo number match those of a CM previously processed, a warning notifies you of the potential duplicate. You may override the warning and continue.
- If the credit memo amount and credit memo date match those of a CM previously processed, a warning notifies you of the potential duplicate. You may override the warning and continue.
- A credit memo may be processed against a payment request, a purchase order, or a vendor, but only one of the three.
- A credit memo processed at the vendor level requires processing on the **Miscellaneous** line. Accounting must be added to the **Miscellaneous** line during processing
- When a credit memo is processed at the level of payment request or purchase order and the purchase order has been closed, you may reopen the purchase order.
- Modification of remit addresses is permitted for a credit memo referencing a PO or a vendor. The address lookup functionality is used to modify the remit address.

- After being approved by AP, accounts cannot be changed on a credit memo.
- The system re-encumbers amounts associated with each line item on a credit memo. The Amount encumbered follows the rules of PO encumbrance (CM Quantity x PO Unit Cost), which is similar to the payment request disencumbrance that utilizes the PO unit cost rather than the PREQ unit cost if the two unit costs are different.
- Accounts encumbered are the accounts on the original PO, with the account distribution in proportion to the distribution on the PO if more than one account is involved per line item. PO open quantities are incremented by the line item quantity on a credit memo.
 - Credit entry: The accounts (full accounting string) on the vendor credit memo are credited in the G/L at the time of AP submit. The G/L entry is made in summary for each accounting string. (So, for example, if three line items on a CM use the same accounting string, only one expense credit entry—not three—is created in the G/L for that accounting string.)
 - Debit entry: Create one offset to object code 9041 for each account and sub-account combination on a CM.
- After being canceled, the G/L entries of the credit memo are reversed, any encumbrance created from AP approval of the credit memo are reversed, and any PO open quantities that were incremented from the creation of the credit memo are decreased.
- FYI notification on a credit memo routes to the fiscal officer or CM delegate per the account number(s) on the credit memo.
- A credit memo may be canceled or placed on hold at any time prior to extraction.
- When a credit memo is in 'AP-Processed' status, it is eligible to be extracted to PDP for disbursement.
- The system groups all PREQs and CMs eligible for extract for disbursement as a positive payment based on vendor and processing campus.
- Credit memo searches are available to all users.

Routing

The Vendor Credit Memo document is initiated by a member of the Accounting-AQ2, -AQ3, -AQ4 roles. Routing is dependent on whether an image attachment is part of an institution's configuration.

- An Accounting-AQ2, -AQ3, or -AQ4 clicks the **submit** button to complete the processing of a Vendor Credit Memo document. The document goes into 'Awaiting AP Review' status if `Require_attachment_ind='Y'`. The AP Review status may be satisfied by an image attachment or in another fashion (configurable at your institution). After AP review, the document routes to the fiscal officer or fiscal officer delegate as an FYI. At the AP Review routing level, approvers are not permitted to change content on the document. They may only add notes and attachments and approve or cancel.
- The document routes an FYI copy to the fiscal officer associated with each account number that appears on the vendor credit memo.

Note

The Timing of G/L Update: After a CM document has been created and submitted, it updates the G/L the next time a batch process runs. Note that this is different from most OLE docs, which do not update the G/L until the document receives all approvals. If accounting entries on the document change before it reaches 'FINAL' status, the G/L entries are updated accordingly the next time a batch process runs.

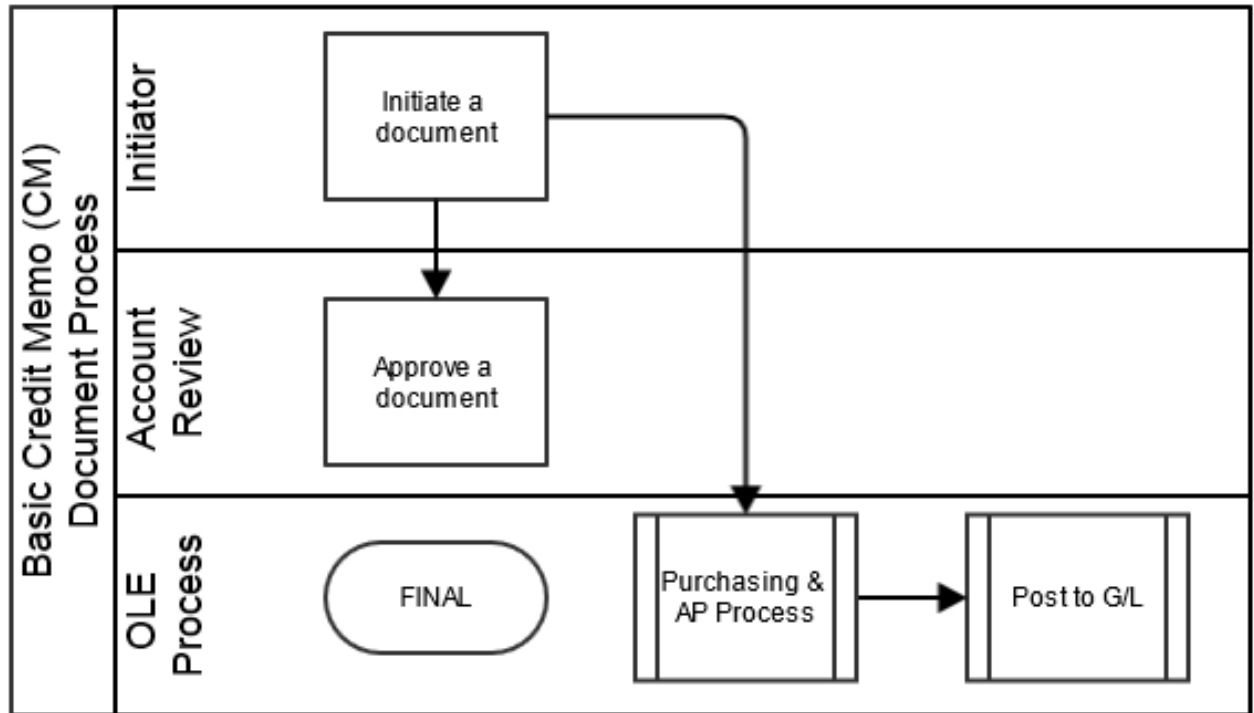

Initiating a Vendor Credit Memo Document

13. Select **Vendor Credit Memo** from the **Purchasing/Accounts Payable** submenu group on the **Transactions** menu group on the **Main Menu** tab.

14. Log into OLE as necessary.

The system displays a blank **Vendor Credit Memo Initiation** tab with a new document ID.

15. Complete the **Credit Memo Initiation** tab as follows:

a) Enter values for **Credit Memo # from Vendor**, **Credit Memo Date**, and **Vendor Credit Memo Amount**.

b) Enter a value for one and only one of these: **Payment Request #**, **Purchase Order #**, or **Vendor #**.

16.

Click



17. Complete the **Vendor** tab as follows:

a) Verify the vendor address.

b) Add check stub notes if requested.

18. Review the **Credit Memo Info** tab and update the bank code, if necessary.

19. Complete the **Process Items** tab as follows:

a) For quantity-based line items, enter the credit memo quantity from the vendor credit.

b) For non-quantity-based line items, enter the credit processed amount using the vendor credit amount.

c) Enter a credit processed amount for additional charges, if needed. Miscellaneous charges require a description, depending on parameter setup.

20. Complete the standard tabs as necessary: **Document Overview**, **Notes and Attachments**, **Ad Hoc Recipients**, and **Route Log**.

Note

For information about the standard tabs, see [Standard Tabs](#) on the *OLE E-Doc Fundamentals* wiki page.

21. Click the  button.

22. Click .

23. AP reviewers approve the document if the parameter `Require_attachment_ind='Y'`.

Note

For more information about how to approve a document, see [Workflow Action Buttons](#) on the *OLE Workflow Overview and Key Concepts* wiki page.

Placing a Credit Memo On Hold

An AP user may choose to place the credit memo on hold or remove the hold when it is no longer necessary. The hold flag prevents a vendor credit memo from being extracted and applied. When a document is taken off hold, it retains the status it had when the hold flag was set.

A credit memo in the 'AP-REVIEW' or 'COMPLETE' status may be placed on hold from the time of AP Submit until the time the credit extracts it to the Pre-Disbursement Processor.

To place a credit memo on hold, you must attach a note to the document explaining why it has been put on hold. To put a credit memo on hold:

24. After displaying the credit memo, click .

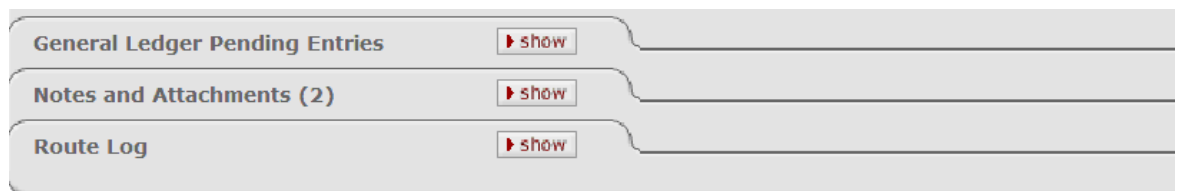

25. Enter a reason for putting the CM on hold and click .

A note is required to place a Credit Memo on hold.

* Please enter the reason below:

Per department, credit already received. Must research.

The system marks the vendor credit memo as being in 'HOLD' status. It also displays a large header on the document indicating who placed the order on hold.

Credit Memo	Doc Nbr:	315517	Status:	FINAL
	Initiator:	appleton	Created:	06:49 PM 09/22/2008
	* CM Nbr:	1002	* CM Status:	COMPLETE

This Credit Memo has been Held by APPLETON,NEAL K

Document Overview			
* Description:	Vendor: ABC CLEANING SERVICES	Explanation:	
* Year:	2008	Org. Doc. #:	
Total Amount:	100.00		

Removing a Vendor Credit Memo Hold

Either the person who placed the credit memo on hold or an AP supervisor may take a vendor credit memo off hold. To take a credit memo off hold:

26. Display the CM and click .

Paying for Materials:
Standard Transactional E-Docs

General Ledger Pending Entries

Notes and Attachments (1)

Route Log

* required field

27. Enter the reason for removing the hold and click .

A note is required to remove hold on a Credit Memo.

* Please enter the reason below:

Confirmed valid credit. Remove Hold to allow extract.

In the **Notes and Attachments** tab, the system displays the history of this action.

Notes and Attachments (2) <input type="button" value="hide"/>				
Notes and Attachments				
	<u>Posted Timestamp</u>	<u>Author</u>	* <u>Note Text</u>	<u>Attached File</u>
add:			<input type="text"/>	<input type="button" value="CANCEL"/>
1	09/22/2007 07:01 PM	APPLETON,NEAL K	Hold Pre department, credit already received. Must research.	
2	09/22/2007 07:10 PM	APPLETON,NEAL K	Remove Hold Confirmed valid credit. Remove Hold to allow extract.	

Example

A vendor issues a \$30.00 credit for two items that were returned after payment was made. An AP user creates a credit memo referencing the payment request document that issued a payment for these two items.

The initiator, a user with the role of Accounting-AQ2, -AQ3, or -AQ4, creates a new credit memo document by entering the vendor credit memo number, amount and date; and one of the following: the payment request number, the PO number, or the Vendor number. When the initiator clicks **continue**, the system generates the Vendor Credit Memo document. In the **Process Items** tab, the initiator enters the quantity being credited and clicks **calculate**. At this point, the document is ready for submission and routing.

Chapter 5. Receiving Materials: Standard Transactional E-docs

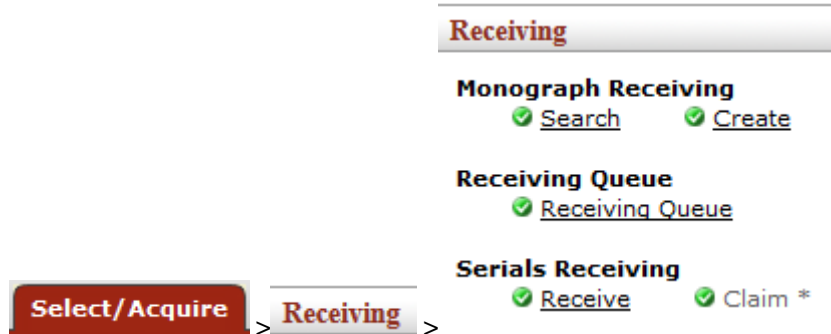

On the Select/Acquire tab, the Receiving submenu provides access to receiving e-documents.

Monograph Receiving Search

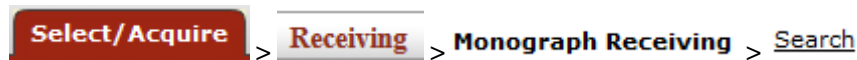

OLE offers a customized document search related to receiving. The search screen contains the standard search fields along with special fields that are unique to this type of e-doc.

Note

For information about performing a search for one or more receiving e-docs, see [Performing Acquisition Searches](#) on the *OLE E-Doc Fundamentals* wiki page.

Note

For information about Document lookup fields that are specific to receiving, see “Document Layout” under [Receiving \(Line Item Receiving\)](#).

Monograph Receiving (Line Item Receiving)

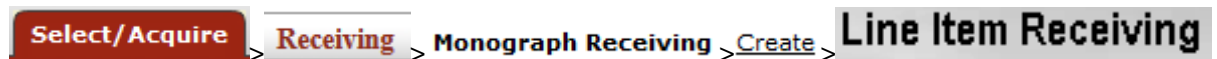

The Line Item Receiving (RCV) document is used to acknowledge the receipt of goods or services on purchase order line items for which a quantity is given. Line item receiving is used to record the quantities of items received, damaged, returned or unordered on a purchase order.

When the purchase order routing is completed and the PO becomes fully approved, if the **Receiving Required** flag is not 'Yes,' the attributes of the purchase order are compared to the Receiving Thresholds table. If one of the attributes on the purchase order matches the Thresholds table, then the **Receiving Required** flag is set to 'Yes'. Amendments are also evaluated to determine whether the flag should be set if payment requests have not yet been processed against the purchase order.

When receiving is required, the Receiving document is processed against a purchase order to satisfy confirmation of satisfactory receipt of the goods.

Note

When receiving is satisfied, the payment request is eligible for auto approval for payment without regard to dollar amount limits. For this reason, it is important that the fiscal officer (or delegate) understand that the receiving document does not replace the fiscal officer (or delegate's) responsibility to confirm that accounts are properly charged and the proper amount is paid. The receiving document satisfies the receipt of goods only. The fiscal officer or delegate is responsible for ensuring that the amounts to be paid are correct and the correct accounts are charged.

Note

When receiving required is 'Yes', the payment request document does not route for fiscal officer approval until sufficient quantity has been documented as received.

Note

The auto approval process is designed to push payments through so that vendors are paid on time. The fiscal officer is permitted to approve all payments, not just those that require positive approval.

Getting Started

In order to receive an item in OLE, you need a corresponding open purchase order that has not been completely received. You should be logged in as a staff member with receiving permissions.

Anyone in the Receiving staff roles can create/complete Receiving documents via Blanket Approve permissions, with no further approvals required. In addition, these staff can create unapproved vendor invoices/payment requests.

Role	Login
Receiving-AQ2	ole-cphovis
Receiving-AQ3	ole-durbin
Receiving-AQ4	ole-cstan; ole-earley
Super user	ole-khuntley (can do all)

Document Layout

Line Item Receiving documents may be created in several ways—by selecting the Search or Create link on the **Select/Acquire** menu or by viewing the purchase order and then clicking the **receiving** button. OLE also contains a [Receiving Queue](#) for quick, straightforward receiving.

Line Item Receiving Initiation Tab

When you first access the Line Item Receiving document, the system displays the **Line Item Receiving Initiation** tab. The fields on the initiation screen are used to detect duplicate entries. Initiating the Line Item Receiving document in this manner allows the system to provide feedback to you regarding potential duplicate entries.

Receiving Materials: Standard Transactional E-docs

Line Item Receiving Initiation

Line Item Receiving Initiation

* Purchase Order #:

* Date Received:

Packing Slip #:

Bill Of Lading #:

Carrier:

continue clear

Here you enter information to create a new Line Item Receiving document.

Line Item Receiving Initiation tab definition

Title	Description
Purchase Order #	Required. Enter the PO number associated with the goods for which line item receiving is being processed.
Date Received	Required. Enter the date of the vendor's receiving document.
Packing Slip #	Enter the packing slip number if included on the receiving document.
Bill of Lading #	Enter the bill of lading number if included on the receiving document.
Carrier	Select from the list to specify the freight carrier used by the Purchasing Department.

Click the  button to display tabs of the main Line Item Receiving document.

Line Item Receiving Document

This main screen for the Line Item Receiving document includes unique **Vendor**, **Titles**, and **Delivery** tabs in addition to the standard tabs that display at the bottom of a financial transaction document.

Note

For more information about the standard tabs, see [Standard Tabs](#) on the *OLE E-Docs fundamentals* wiki page.

Receiving Materials: Standard
Transactional E-docs

Line Item Receiving Doc
Init

Document Overview ▼ hide

Document Overview

* **Description:** PO: 1016 Vendor: YBP Library Services

Organization Document Number:

Explanation:

Vendor ▼ hide

Vendor Address

* **Vendor:** YBP Library Services

Vendor #: 12106-0

* **Address 1:** 999 Maple Street

Address 2:

* **Date Received:** 10/07/2013

Packing Slip #:

Bill Of Lading #:

Titles ▼ hide

Receiving Line Items

Line #	Vendor Item Identifier	Description	Format	Qty Ordered	No Parts Ordered	Prior Qty Rcd	Prior Parts Rcd	Qty to be Rcd	Parts to be Rcd	Item Received Total Quantity	Item Received Total Parts	Item Returned Total Quantity	R
1		LOVE POEMS, LETTERS, AND REMEDIES OF OVID; TRANS. BY DAVID R. SLAVITT., OVID, 43 B.C.-17 OR 18 A.D., HARVARD UNIV PRESS, 9780674059047		1	1	0	0	1	1	0	0	0	0

▼ hide

Bib Info: **Bib Editor** **Action:**

Exception Notes

Receipt Notes

Special Processing Instructions

Delivery

View Related Documents

Notes and Attachments (0)

Route Log

Document Overview Tab

The **Document Overview** tab is standard except that the **Description** field defaults to the purchase order number and vendor's name.

Document Overview ▼ hide

Document Overview

* **Description:** PO: 1016 Vendor: YBP Library Services

Organization Document Number:

Explanation:

Receiving Materials: Standard
Transactional E-docs

Document Overview tab definition

Title	Description
Description	Defaults to the purchase order number and vendor's name
Org. Doc. #	The organization document number. If the organization does not use an internal referencing system, this field is left blank.
Explanation	Allows you to include additional information about the document that does not fit into the Description field (which is limited to 40 characters).

Vendor Tab

The **Vendor** tab contains vendor details related to the items being received.

Vendor			
Vendor Address			
* Vendor:	YBP Library Services	* City:	Contoocook
Vendor #:	12106-0	State:	NH
* Address 1:	999 Maple Street	*required for US Postal Code:	03229
Address 2:		*required for US Country:	United States
* Date Received:	08/03/2012	Reference #:	
Packing Slip #:		Carrier:	
Bill Of Lading #:			

Vendor tab definition

Title	Description
Vendor	Display-only. The vendor name from the Purchase Order document.
Vendor #	Display-only. The OLE-generated identifying number assigned to this vendor.
Address 1	Display-only. The first line of the address for the selected vendor.
Address 2	Display-only. The second line of the address for the selected vendor.
Date Received	Required. Defaults from the initiation tab but can be changed.
Packing Slip #	Defaults from the Line Item Receiving Initiation tab but can be edited.
Bill of Lading #	Defaults from the Line Item Receiving Initiation tab but can be edited.
City	Display-only. The city associated with this vendor. This entry is required under certain circumstances (such as, for a U.S. address).
State	Display-only. The state associated with this vendor.
Postal Code	Display-only. The postal code for this vendor address. Postal codes are required under certain circumstances (such as, for a U.S. address).
Country	Display-only. The country associated with this vendor.
Reference #	Allows you to add additional information that will assist with document searching.
Carrier	Defaults from the Line Item Receiving Initiation tab but can be edited.

Title Tab

The **Title** tab displays the lines of the PO that this receiving document relates to. On this tab the quantity received for each line item number is recorded. If known at this time, quantity returned and quantity damaged are also recorded; otherwise, this information can be added later by using the Receiving Correction document. Click to receive the title, click **edit** to access the Bibliographic Editor and modify the record.

Receiving Materials: Standard
Transactional E-docs

Titles												
Receiving Line Items												
Line #	Vendor Item Identifier	Description	Format	Qty Ordered	No Parts Ordered	Prior Qty Rcd	Prior Parts Rcd	Qty to be Rcd	Parts to be Rcd	Item Received Total Quantity	Item Received Total Parts	Item Returned Total Quantity
▼ hide												
1		LOVE POEMS, LETTERS, AND REMEDIES OF OVID; TRANS. BY DAVID R. SLAVITT., OVID, 43 B.C.-17 OR 18 A.D., HARVARD UNIV PRESS, 9780674059047		1	1	0	0	1	1	0	0	0
Bib Info:		Bib Editor	<input type="button" value="edit"/>	Action:		<input type="button" value="receive"/>						
<input type="button" value="show"/>		Exception Notes										
<input type="button" value="show"/>		Receipt Notes										
<input type="button" value="show"/>		Special Processing Instructions										

Receiving Titles section

Titles tab definition

Title	Description
Line #	Display-only. The line number on the receiving document. The line number corresponds to the line number on the purchase order.
Vendor Item Identifier	Display-only (optional for new line items) Identifies a vendor item identifier if one has been provided by a vendor.
Description	Concatenated data values from the related bibliographic description.
Format	Display-only (optional for new line items). Identifies the Format for this line item.
Qty Ordered	Display-only. Indicates the original quantity ordered from the purchase order.
No. of Parts Ordered	Display-only. Indicates the original number of individual pieces ordered from the purchase order.
Prior Qty Received	Display-only. Indicates the sum of total quantity received minus total quantity returned from all previously submitted Line Item Receiving documents.
Prior Parts Rcd	Display-only. Indicates the sum of total of parts received minus total parts returned from all previously submitted Line Item Receiving documents.
Qty to be Received	Display-only. The Quantity Ordered minus the Prior Quantity Received .
Parts to be Rcd	Display-only. The No. Parts Ordered minus the Prior Parts Received .
Item Received Total Quantity	The quantity of this item received in this shipment. Note If you receive additional copies of an item, you will need to fill in the Copies section.
Item Received Total Parts	The parts of this item received in this shipment.
Item Returned Total Quantity	The quantity to be returned to the vendor.
Item Returned Total Parts	The parts to be returned to the vendor.
Item Damaged Total Quantity	The quantity received that was damaged.
Item Damaged Total Parts	The part(s) received that was (were) damaged.
Addition Reason	Required. When adding items, indicates the reason this line item is being added (i.e., 'substitution' or 'not on order').
Available to the Public	Optional. Indicates whether or not a bibliographic description shall be exposed to users prior to purchase/receipt. Default is checked for yes.

Bib Info

To modify the bibliographic record, click **edit**. Click **receive** to receive the item.

Note

In prior versions of OLE, users could add additional line items from the Receiving Document. In 1.0, users must access the open Purchase Order and amend it to add additional items.

Notes and Instructions

OLE provides three forms of receiving line item notes that are specific to receiving activities:

- **Exception Notes:** to note damaged, unusual, or other exceptions for the line item. Future workflow rules will be tied into exception notes.
- **Receipt Notes:** general notes for recording receipt statements on the item in hand
- **Special processing instructions:** users cannot input these instructions during receiving, but are required to check-off, or acknowledge any special instructions transferred from the Purchase Order for this line item- this must be completed prior to submitting the document.

	PERSIANS, SEVEN AGAINST THEBES, AND SUPPLIANTS; TRANS. BY AARON POOCHIGIAN.,AESCHYLUS,JOHNS HOPKINS UNIV PRESS,9781421400648		1	1	1	1	0	0	0	0	0	0
	Bib Info:	Bib Editor	<input type="button" value="edit"/>	Receipt Status:	Received							
1	▼ hide Exception Notes											
	Exception Type:						Note:					
	Received-damaged ▼						<input type="text"/>					
1	▼ hide Receipt Notes											
	Note Type:						Note:					
	Miscellaneous/Other Note ▼						<input type="text"/>					
1	▼ hide Special Processing Instructions											
	Special Processing Instructions											

Multiple Copies

If there are multiple copies ordered, you will need to receive each one individually from the **Copies** section.

In the **Copies** section, click the button.

Receiving Materials: Standard
Transactional E-docs

Item 2										
2	Bib Info:	The Lorax					Item Type			
	* No of Copies Ordered	2	* No of Parts Ordered	2	* List Price	19.00	Extended Cost	38.00		
	Receipt Status		No Of Copies Received	0	No of Parts Received	0	Item Price Source	Publisher		
	Format		Category		Vendor Item Identifier	100550239	Requestor	HUNTLEY, KEISHA Y		
	Unit Cost	19.0000	Discount	0.00	Discount Type	%				
<input type="button" value="show"/> Notes <input type="button" value="show"/> Accounting Lines <input type="button" value="show"/> Copies  <input type="button" value="show"/> Payment History										
Additional Charges <input type="button" value="show"/>										

The expanded section appears:

Line #	Vendor Item Identifier	Description	Format	Qty Ordered	No Parts Ordered	Prior Qty Rcd	Prior Parts Rcd	Qty to be Rcd	Parts to be Rcd	Item Received Total Quantity	Item Received Total Parts	Item Returned Total Quantity	Item Returned Total Parts
1		RIGHTS OF MY PEOPLE : LILLIUKALANI'S ENDURING BATTLE WITH THE UNITED STATES, 1893-1917.,PROTO, NEIL THOMAS,ALGORA PUBLISHING,9780875867205		2	1	0	0	2	1	0	0	0	0
Bib Info:		Bib Editor	<input type="button" value="edit"/>										
<input type="button" value="show"/> Exception Notes													
<input type="button" value="show"/> Receipt Notes													
<input type="button" value="show"/> Special Processing Instructions													
<input type="button" value="hide"/> Copies													
Enumeration:				Location:				Copy Number:					
Copies 1													
1				B-WELLS/BWE-RCSTACKS				1					
Copies 2													
1				B-WELLS/BWE-RCSTACKS				2					

Copies section definition

Title	Description
Enumeration	Descriptive information for the numbering scheme of the item.
Location	The home location of the title being requested.
Copy Number	Identifies the number of copies a library location has of the same item.
Receipt Status	Display only. Identifies the receiving status of the item.
Action	Click <input type="button" value="receive"/> to receive the item and update the receipt status.

Delivery Tab

The **Delivery** tab contains information about where goods ordered on this order should be delivered. It also displays delivery contact information and any special delivery instructions. All fields in this tab come from the purchase order's **Delivery** tab.

Final Delivery		* Delivery To:	RENFWOW, R
* Delivery Campus:	BL	Phone Number:	
Building:		Email:	
* Address 1:	400 E 7th St	Date Required:	
Address 2:	Poplars Bldg	Date Required Reason:	
* Room:	402	Delivery Instructions:	LEAVE ON D
* City:	Bloomington		
* State:	IA		
* Postal Code:	47405		
Country:	UNITED STATES		

Delivery tab definition

Title	Description
Delivery Campus	The campus code where the goods were delivered.
Building	The building where the goods were delivered.
Address 1	Address line 1 where the goods were delivered.
Address 2	Address line 2 where the goods were delivered.
Room	The room number where the goods were delivered.
City	The city where the goods were delivered.
State	The state where the goods were delivered.
Postal Code	The postal code where the goods were delivered.
Country	The country where the goods were delivered.
Delivery To	The person to whom the delivery was made.
Phone Number	The phone number of the delivery-to person. (Formatted: xxx-xxx-xxxx)
Email	The email address of the delivery-to person.
Date Required	The date the delivery was required.
Date Required Reason	If a date required was entered the date required reason is displayed here.
Delivery Instructions	Displays any special delivery instructions for the items.

Process Overview

To receive the item in hand:

1. Open the **Line Item Receiving** edoc.
2. In the **Titles** tab, click **receive** under the **Action** column.
3. Once you have received all the items you want from this Purchase Order, click the **blanket approve** button at the bottom of the screen. This changes the status of the Receiving e-Doc to "Complete", and prevents any further receiving on it.

Tip

Tip: The **blanket approve** option will only appear if you are logged in as a member of the OLE_RCV or OLE-Receive-Mgr groups. Otherwise (if you are a member of OLE-

Invoicing), you must click on the  button, review the route log by opening the **Route Log** tab and click  next to **Future Action Requests**.

To receive a partial shipment, only receive the items that are in hand.

To return items, enter quantities in the **Item Returned** fields or **Item Damaged** fields and add an exception note. The Purchase Order will reflect the return.

Receiving Damaged Items or Exceptions

To receive damaged items or exceptions, on the **Titles** tab of the **Receiving** e-document:

1. Open the **exception notes** subtab.

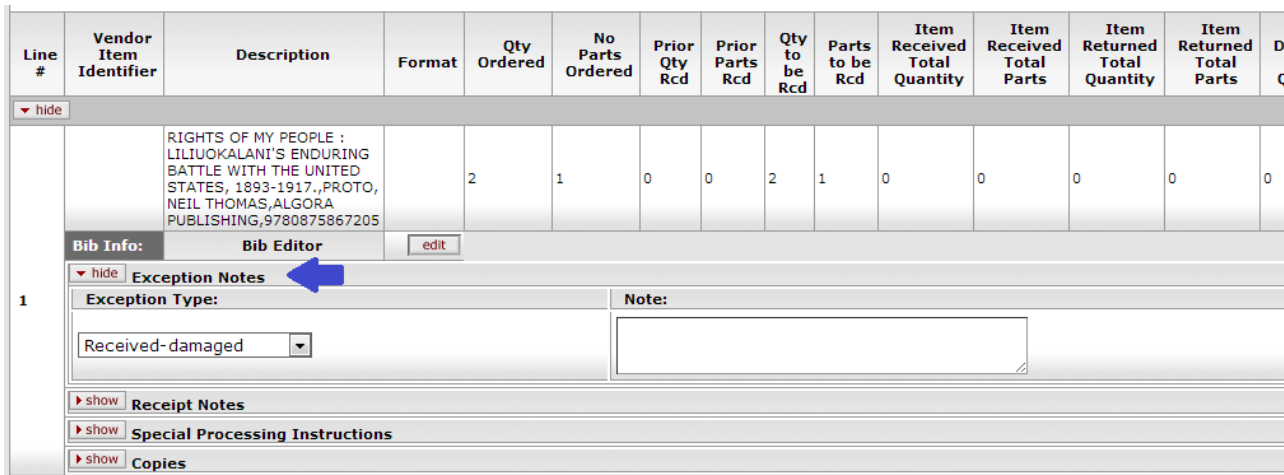

Line #	Vendor Item Identifier	Description	Format	Qty Ordered	No Parts Ordered	Prior Qty Rcd	Prior Parts Rcd	Qty to be Rcd	Parts to be Rcd	Item Received Total Quantity	Item Received Total Parts	Item Returned Total Quantity	Item Returned Total Parts	D
1		RIGHTS OF MY PEOPLE : LILUOKALANI'S ENDURING BATTLE WITH THE UNITED STATES, 1893-1917.,PROTO, NEIL THOMAS,ALGORA PUBLISHING,9780875867205		2	1	0	0	2	1	0	0	0	0	0

Bib Info: **Bib Editor**

Exception Notes

Exception Type:

Note:

Receipt Notes

Special Processing Instructions

Copies

2. Select the **Exception Type** from the dropdown list.
3. Add an exception note as needed.
4. Click .

Receiving Correction

Receiving corrections are a version of receiving for use after receiving has been completed and approved. While authorized users may continue to initiate multiple receiving documents on a single Purchase Order (subject to quantities ordered), corrections to a single document are accomplished via Receiving Correction.

Search for and open the correct receiving document. At the bottom of the screen click **correction**.

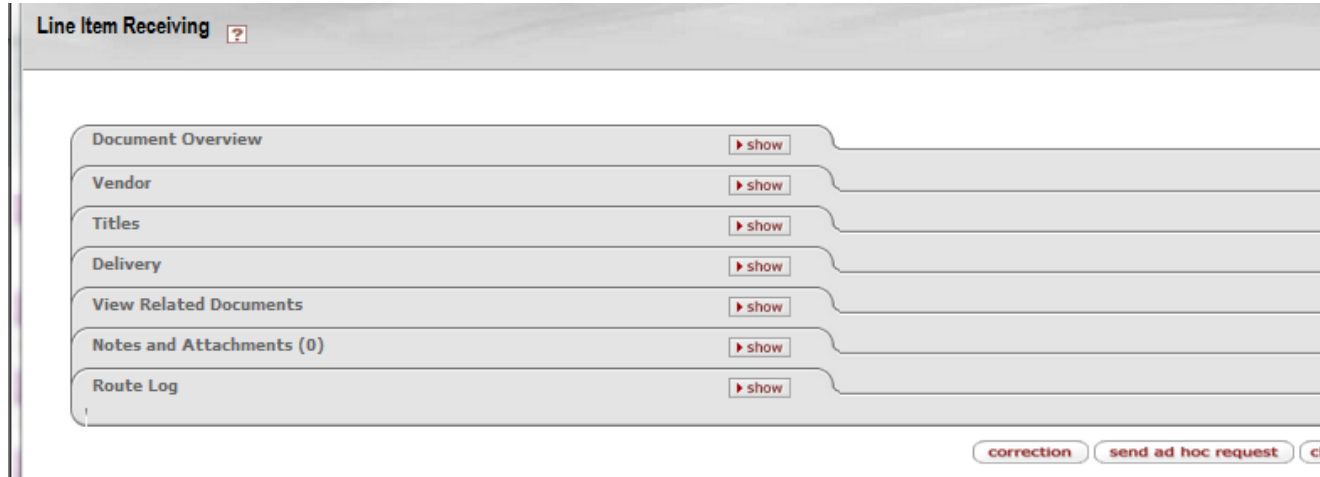

A popup window will appear allowing users to enter a note. This note is required to correct the receiving document. Click **yes** to proceed to the Receiving screen and make modifications or unreceive items.

Business Rules

- When the Receiving document is submitted, the **No Of Copies Received** and **No Of Parts Received** fields are updated on the purchase order with the **Receipt Status** reflecting the item's Receiving status.
- Notes in the **Notes and Attachments** tab are used to record any additional detail about damaged goods.
- After the document has been submitted, a correction document needs to be processed to reduce or increase the quantity received, returned, and/or damaged if the original entered amounts are determined to be in error.

Routing

If other receiving or payment actions are in progress against this Purchase Order and receiving document (i.e., and not yet approved), you may be prohibited from processing additional receiving until completed.

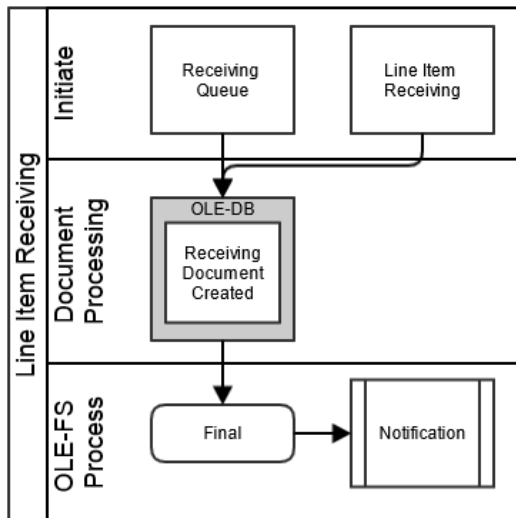

Receiving Queue: Express Receiving

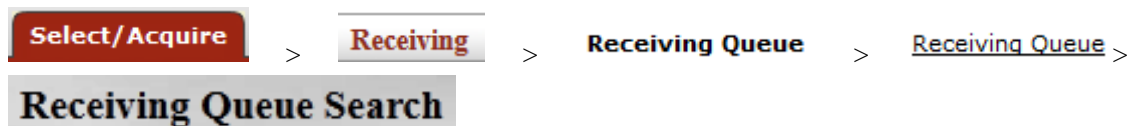

The Receiving Queue is intended to be a quicker way to do straightforward receiving, when you have in hand the title and quantity that were originally ordered, with no changes needed. The Receiving Queue screen also allows users to search by bibliographic data.

Purchase orders with special processing instructions are filtered out of Receiving Queue searches, and must be received via the standard Line Item Receiving document. Additionally, items that have been damaged, returned, or are only part of an order must also be received through the Line Item Receiving document.

Note

For information about Line Item Receiving, see [Receiving \(Line Item Receiving\)](#).

To successfully complete receiving with this method you must be logged in as a member of one of the following groups:

Role	Login
OLE_SELECT Acquisitions-AQ2	ole-cphovis
OLE_SELECT Acquisitions-AQ3	ole-cstan, ole-durbin
OLE_SELECT Acquisitions-AQ4	ole-earley
OLE_SELECT Acquisitions-AQ5	ole-ejacob; ole-fermat

If you are not logged in as a member of OLE_RCV or OLE-Receive-Mgr, the receiving document will be routed to a member of OLE_RCV for final approval.

Click on the **Receiving Queue** link from the **Main Menu**.

It will bring you to this screen:

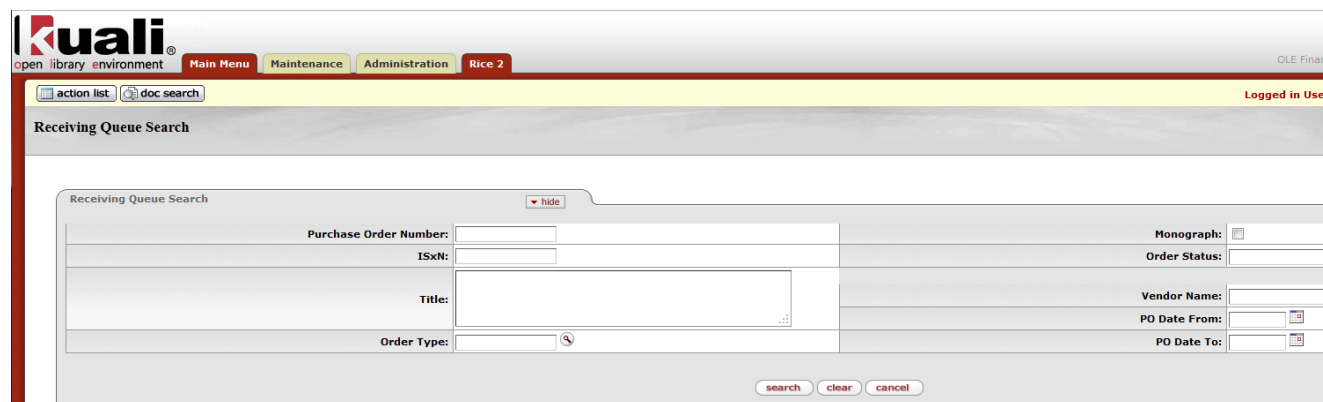

The screenshot shows the 'Receiving Queue Search' interface. At the top, there is a navigation bar with 'Main Menu', 'Maintenance', 'Administration', and 'Rice 2'. Below this is a search bar with 'action list' and 'doc search' buttons. The main content area is titled 'Receiving Queue Search' and contains a form with the following fields: 'Purchase Order Number:', 'ISxN:', 'Title:', 'Order Type:', 'Monograph:', 'Order Status:', 'Vendor Name:', 'PO Date From:', and 'PO Date To:'. There are 'search', 'clear', and 'cancel' buttons at the bottom right of the form.

In the left-hand fields, you can search by Purchase Order number or certain bibliographic fields. The right-hand column allows you to limit your searches to monograph only, order status, by vendor, or purchase order dates.

This search filters for all Purchase Orders with Open statuses that have no Special Processing Instruction Notes that may have been entered on the original Requisition. (Special Processing Instruction Notes require acknowledgement during receiving. Titles with special processing instruction notes therefore cannot be received via the Receiving Queue.)

Note

To learn more about searching, see [Searching OLE](#) on the *OLE E-Docs fundamentals* wiki page.

Click .

The PO search results are retrieved and the user can choose to **Receive**, **Create Receiving**, **Pay**, or **Receive and Pay**.

Receive

This choice will allow the PO to be received without creating a payment or a general ledger entry and the PO document will move to fully received.

Click the **check box** to the left of the title(s) you want to receive, and then click the **receive** button at the bottom of the page:



<input checked="" type="checkbox"/>	1059	ALEPH-BET BOOKS	Fat Willy's.				1	1
<input type="checkbox"/>	1048	YBP Library Services	How to Install Carpet				1	1
<input checked="" type="checkbox"/>	1060	YBP Library Services	Title of Book				1	1

select all from all pages deselect all from all pages select all from this page deselect all from this page

Actions ▼ hide

receive create receiving pay receive and pay

If this action completes the receiving expected for a given Purchase Order, the system replies in the **Actions** tab:

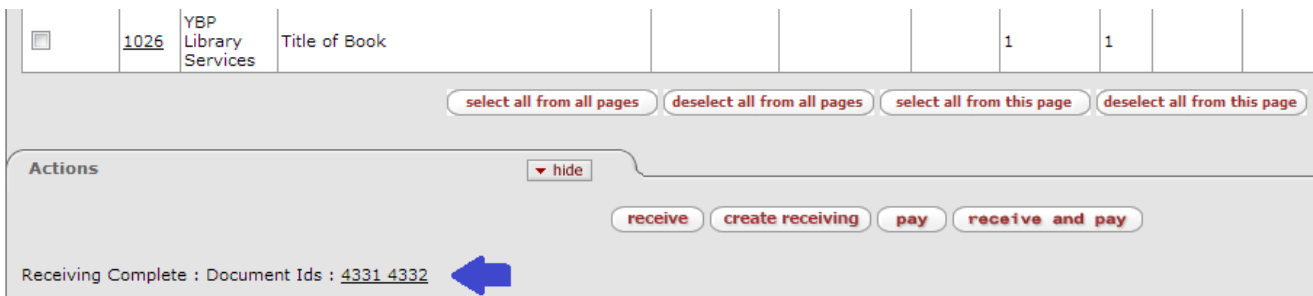

<input type="checkbox"/>	1026	YBP Library Services	Title of Book				1	1
--------------------------	------	----------------------	---------------	--	--	--	---	---

select all from all pages deselect all from all pages select all from this page deselect all from this page

Actions ▼ hide

receive create receiving pay receive and pay

Receiving Complete : Document Ids : [4331 4332](#) 

Create Receiving

This choice will allow for the Line Item Receiving of the PO document. It allows for changes to be made to the receiving information and the PO to move to the status or received.

Click the **check box** to the left of the title you want to create a receiving document for, and then click the **create receiving** button at the bottom of the page:

<input checked="" type="checkbox"/>	<u>1025</u>	YBP Library Services	Title of Book				1	1		
<input type="checkbox"/>	<u>1026</u>	YBP Library Services	Title of Book				1	1		

[select all from all pages](#) [deselect all from all pages](#) [select all from this page](#) [deselect all from this page](#)

Actions ▼ hide

[receive](#) [create receiving](#) [pay](#) [receive and pay](#)

This will bring up the Line item Receiving e-document.

Note

For information about Line Item Receiving see [Receiving \(Line Item Receiving\)](#)

Pay

This choice will allow open and received PO documents with no payments to be paid. These payments are made by creating a new invoice or adding PO to an existing invoice.

Click the **check box** to the left of the title(s) you want to receive, and then click the **pay** button at the bottom of the page:

<input checked="" type="checkbox"/>	<u>1025</u>	YBP Library Services	Title of Book				1	1		
<input type="checkbox"/>	<u>1026</u>	YBP Library Services	Title of Book				1	1		

[select all from all pages](#) [deselect all from all pages](#) [select all from this page](#) [deselect all from this page](#)

Actions ▼ hide

[receive](#) [create receiving](#) [pay](#) [receive and pay](#)

This will bring up the **Add Pay and Receiving Pay** screen.

Add pay and Receiving Pay

Titles

Show entries

<input type="checkbox"/>	PurchaseOrder Id#	Vendor Name	Item Description	Item Title	Item Author	No of Copy Received	No of Part Received
<input checked="" type="checkbox"/>	1025	YBP Library Services	Title of Book				

Showing 1 to 1 of 1 entries

Add Titles To New Invoice

Invoice Date:  Vendor Invoice amount: Vendor Invoice Number:

Payment Method:

Add Titles To Existing invoice

Invoice Document Number: 

Users may choose to add titles to a new invoice or to an existing invoice.

Add Titles to New Invoice

To add titles to a new invoice, enter the **Invoice Date** or search for it from the calendar icon .

Check the **Vendor Invoice Amount**

Enter a **Vendor Invoice Number** and select the **Payment Method** from the dropdown list.

Click

The invoice is created. A success message is provided below the **Add pay and Receiving Pay** title containing the invoice document ID. Click the hyperlinked document ID to access the invoice.

Add Titles to Existing Invoice

To add titles to an existing invoice, enter the invoice number in the **Invoice Document Number** or search for it from the lookup .

Click

The existing invoice is updated. A success message is provided below the **Add pay and Receiving Pay** title containing the invoice document ID. Click the hyperlinked document ID to access the invoice.

Receive and Pay

This option will allow payment of PO documents while receiving line items. This can be used for prepayments of purchase orders or used to expend a fund.

Click the **check box** to the left of the title(s) you want to receive and pay for, and then click the **receive and pay** button at the bottom of the page:

<input checked="" type="checkbox"/>	1025	YBP Library Services	Title of Book				1	1		
<input type="checkbox"/>	1026	YBP Library Services	Title of Book				1	1		

select all from all pages deselect all from all pages select all from this page deselect all from this page

Actions ▼ hide

receive create receiving pay **receive and pay**

This will bring up the **Add Pay and Receiving Pay** screen.

Add Titles to New Invoice

To add titles to a new invoice, enter the **Invoice Date** or search for it from the calendar icon .

Check the **Vendor Invoice Amount**

Enter a **Vendor Invoice Number** and select the **Payment Method** from the dropdown list.

Click .

The invoice and the receiving document are created. A success message is provided below the **Add pay and Receiving Pay** title containing the document IDs. Click the hyperlinked document IDs to access the documents.

Note

Receiving is not complete until the document is submitted. If the process is cancelled, the items will not be received within OLE.

Add Titles to Existing Invoice

To add titles to an existing invoice, enter the invoice number in the **Invoice Document Number** or search for it from the lookup .

Click .

The existing invoice is updated and a receiving document is created. A success message is provided below the **Add pay and Receiving Pay** title containing the invoice document ID. Click the hyperlinked document IDs to access the documents.

Note

Receiving is not complete until the document is submitted. If the process is cancelled, the items will not be received within OLE.

Serials Receiving Transaction

[Select/Acquire](#) > [Receiving](#) > [Serials Receiving](#) > [Receive](#) >

[Serials Receiving Record Search](#) >

[Serial Receiving Transaction](#)

Getting Started

Serials Receiving Record Search

▼ Search Conditions:

Search By: <input type="text" value="Title"/>	Search Type: <input type="text" value="All of these"/>	Search For: <input type="text"/>	Operator: <input type="text" value="AND"/>
Search By: <input type="text" value="ISSN"/>	Search Type: <input type="text" value="All of these"/>	Search For: <input type="text"/>	Operator: <input type="text" value="AND"/>
Search By: <input type="text" value="Serials Receiving Record No"/>	Search Type: <input type="text" value="All of these"/>	Search For: <input type="text"/>	Operator: <input type="text" value="AND"/>
Search By: <input type="text" value="Bibliographic Record No"/>	Search Type: <input type="text" value="All of these"/>	Search For: <input type="text"/>	Operator: <input type="text" value="AND"/>
Search By: <input type="text" value="Purchase Order No"/>	Search Type: <input type="text" value="All of these"/>	Search For: <input type="text"/>	Operator: <input type="text" value="AND"/>

▼ Search Results:

Document Overview

Receiving Materials: Standard
Transactional E-docs

Webpage Screenshot

Serial Receiving record

Title:	BIAC journal.
Author:	
PO ID:	
Vendor Alias Name:	<input type="text"/> select vendor
Instance Record:	wno-18 relink
Bound Location:	B-FINEARTS/BH-WRIGHT/I-DENTS
* Subscription Status:	<input type="text"/>
Print Label:	<input type="checkbox"/>
Claim:	<input type="checkbox"/>
Copy Number:	<input type="text"/>
General Receiving Note:	<input type="text"/>
* Receiving Record Type:	Main <input type="text"/>

Receive Enum/Chron Captions

Action Interval(* for claim):	<input type="text"/>	Action Date(*
-------------------------------	----------------------	---------------

Enumeration						Chronology					
L1	<input type="text"/>	L2	<input type="text"/>	L3	<input type="text"/>	L1	<input type="text"/>	L2	<input type="text"/>	L3	<input type="text"/>
	<input type="text"/>		<input type="text"/>		<input type="text"/>		<input type="text"/>		<input type="text"/>		<input type="text"/>

[receive](#) [special issue](#) [claim](#)

Route Log

[save](#) [return to search](#) [delete](#)

http://tst.ole.kuali.org/ole-kr-krad/serialReceiving?viewId=OLESerialReceivingView&methodToCall=docHandler&command=initiate&bibId=wbm-10000017&instanceId=wno-18

This main screen for the Serials Receiving Transaction document includes unique **Serials Receiving Record**, and **Receive Enum/Chron Captions** tabs in addition to the standard Route Log tab that display at the bottom of a document.

Note

For more information about the route log, see [Route Log](#) on the *OLE Workflow Overview and Key Concepts* wiki page.

Serials Receiving Record Tab

Serial Receiving record	
Title:	BIAC journal.
Author:	
PO ID:	
Vendor Alias Name:	<input type="text"/> <input type="button" value="select vendor"/>
Instance Record:	wno-18 <input type="button" value="relink"/>
Bound Location:	B-FINEARTS/BH-WRIGHT/I-DENTSTR
* Subscription Status:	<input type="text"/> ▼
Print Label:	<input type="checkbox"/>
Claim:	<input type="checkbox"/>
Copy Number:	<input type="text"/>
General Receiving Note:	<input type="text"/>
* Receiving Record Type:	Main ▼

Serials Receiving Record tab definition

Title	Description
Title	
Author	
PO ID	
Vendor Alias Name	
Instance Record	
Bound Location	
Subscription Status	
Print Label	
Claim	
Copy Number	
General Receiving Note	
Receiving Record Type	
ISSN	
Publisher	
Bib Record ID	
Vendor Name (*for a claim)	

Receiving Materials: Standard
Transactional E-docs

Call Number
Unbound Location
Serials Receipt Work Unit
Public Display
Create Item
Urgent Note
Treatment Instruction Note
Claim Information

Receive Enum/Chron Captions Tab

▼ Receive Enum/Chron Captions

Action Interval(* for claim):

Action Date

Enumeration

L1
L2
L3
L4
L5
L6

Chronology

L1
L2
L3

receive
special issue
claim

Receive Enum/Chron Captions tab definition

Title	Description
Action Interval (* for claim)	
Action Date (* for claim)	
Enumeration L1-L6	
Chronology L1-L4	

Chapter 6. Fund

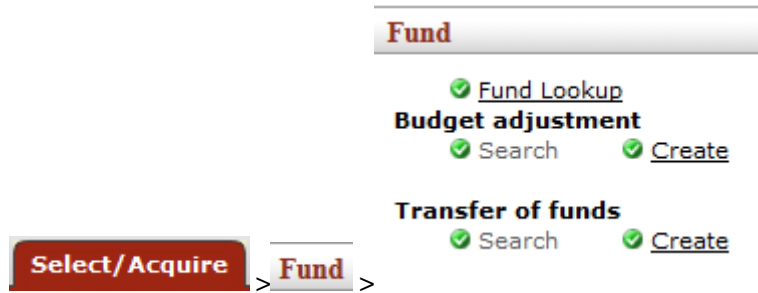

On the Select/Acquire tab, the Fund submenu provides access for users to import manage library funds.

General Ledger

The General Ledger (GL) contains numerous processes that ensure that OLE runs correctly. For users processing e-doc transactions, the most apparent of these processes are the generation of offsets and the posting of transactions to the balance tables. Other important General Ledger processes are less apparent to users. These processes ensure that transaction data are valid, that capitalization entries are created, and that indirect cost recovery and cost share transfers occur. OLE also offers related features such as sufficient funds checking and flexible offsets for institutions that want to utilize this functionality.

OLE will apply encumbrances and expenses to the General Ledger as a result of OLE implemented functionality for encumbrances, expenses, budget adjustments and transfers of funds. Real-time GL posting is made available, with certain GL entries updating their status through nightly “batch jobs”.

In OLE 1.0 and 1.5, we will be reconciling university financial integrations and OLE’s use of Budget vs. Actual (cash) balances.

Requisition

- No GL entries for this form of “pre-order”

Purchase Order, Purchase Order Amendment, other forms of PO

- A final, “approved” Purchase Order will apply an encumbrance to the General Ledger as “pending”. During nightly batch jobs, the pending entry goes to “final”. Pending GL entries will be visible on the PO’s General Ledger Pending Entries tab, and be reflected in balance inquiries when “pending” or “all” transactions included.
- Sample: pending GL entry from approved PO with default (OLE Sample Data/object code 9892- RESV OUTSTANDING ORDR EXTRNL ENCUMBRNCES, Credit offset to the purchase order Debit) Offset- not yet processed through nightly batch job

General Ledger Pending Entries ▼ hide

General Ledger Pending Entries						
Seq #	Fiscal Year	Chart	Account Number	Sub-Account	Object	Sub-Object
1	2012	BL	2947482	----	7112	---
2	2012	BL	2947482	----	9892	---

Notes and Attachments (0) ▶ show

Ad Hoc Recipients ▶ show

Route Log ▶ show

sensitive data print send ad hoc

- Sample: PO that has processed to nightly batch job- no pending GL entries

General Ledger Pending Entries ▼ hide

General Ledger Pending Entries

There are currently no General Ledger Pending Entries associated with this T

Notes and Attachments (1) ▶ show

Ad Hoc Recipients ▶ show

Route Log ▶ show

sensitive data open order receiving print send ad hoc

Payment Request

- As PREQ's are payments to vendors, any PREQ created with accounting lines will post to the GL as "pending" whether it has completed workflow or not (unlike PO which must be final/approved).
- PREQ will reverse the encumbrance, as noted on the e-Doc, and apply the expense immediately.
- Nightly batch jobs will take approved PREQ's to final status, and also apply liabilities to the balance sheet.
- Sample, PREQ with relieved encumbrance:

Process Items ▼ hide

Purchase Order Line Item Totals	
Encumbrance excluding freight & s/h	Total Encumbrance Amount Relieved
179.00	179.00

- Sample: General Ledger Pending entries on approved PREQ (encumbrance and initial offset from PO are reversed. Expense applied with offset to Acct Payable/liability object code 9041):

General Ledger Pending Entries					
Seq #	Fiscal Year	Chart	Account Number	Sub-Account	
1	2012	BL	2947482	----	71
2	2012	BL	2947482	----	98
3	2012	BL	2947482	----	71
4	2012	BL	2947482	----	90

Notes and Attachments (0) [▶ show](#)

Ad Hoc Recipients [▶ show](#)

Route Log [▶ show](#)

Fund Lookup

Tip

OLE is cloud-based, allowing users to have multiple browser windows open. If a user wants to query multiple Account-Objects for available balances, while having a transaction open in another window- that user could jump through multiple queries or details in one window, then just copy/paste preferred Chart, Account, Object codes into the Accounting lines of an open transactional document in another window- Requisition, Purchase Order, Payment Request, Transfer of Funds etc.

[Select/Acquire](#) > [Fund](#) > [Fund Lookup](#)

Sufficient Funds Checking is commonly used with the understanding that (a) some orders are never filled, and therefore their commitments will never become expenditures, and (b) at the end of the fiscal year, not all accounts are fully spent and there will be money left over to cover the overcommitments or overexpenditures assigned to accounts fully spent. The budget administrator must keep in mind that all accounts cannot be overcommitted or overspent and that the total expenditure for all accounts cannot be greater than the total allocation for all accounts, dependent upon fund attributes.

SFC checks would operate differently on encumbrances vs. expenditures

- encumbrances would check against Free Balances (Budget - invoices (liabilities) [pending included] - expenditures [pending included] - encumbrances [pending included]), occurs when encumbrances is pending (when requisition created/accts and costs assigned)
- expenditures would check against Cash Balance (Budget - expenditures [pending included]) - when Payment Request created (pending).

Fund Lookup allows operators to check the account balance at the time of assigning accounts to line items on requisitions, purchase orders, payment requests, disbursement vouchers, etc. The lookup also allows operators to check balances in advance, rather than waiting until the document is submitted to find out whether the account has enough money.

Query Available Account Balances: Requisition (Purchase Order, Payment Request) Line Item

Available Balance details can also be accessed from the Requisitions page by clicking on the **bal inquiry** button *after you have added an accounting line:*

The screenshot displays a requisition line item form. The 'Current Items' section includes a table with columns for Item Line #, Item Type, Quantity, No. of Parts, and UOM. Item 1 is shown with a quantity of 1.00 and UOM of EACH. Below this, there are fields for Bib Info (Bib Editor, Title: Frank Lloyd Wright) and Options (Format, Category). A 'show Notes' button is visible. The 'Accounting Lines' section is expanded, showing a table with columns for * Chart, * Account Number, and Sub-Account. The first row shows 'BL' (BLOOMINGTON) and '2947489' (FRENCH & ITALIAN). To the right, a partial view of another table shows columns for Extended Cost (0.00) and Tax Amount (0.00).

From the **Balance Inquiry Report Menu**, select **Available Balances**:

Balance Inquiry Report Menu

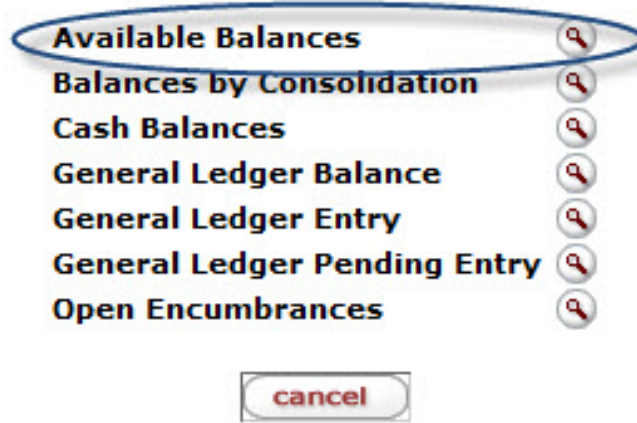

To return to the requisition, click the button on each screen.

Lookup Criteria

Fill in at least **Chart Code**, **Account Number** and **Object Code**. Use the **lookup**  as necessary to select the criteria. The lookup criteria defaults to the current fiscal year.

Click .

Ole Fund Lookup

Ole Fund Lookup ▼ hide

	Keyword : <input style="width: 90%;" type="text"/>
	* Chart Code: <input style="width: 80%;" type="text"/> <input type="button" value="🔍"/>
	Organization Code: <input style="width: 80%;" type="text"/> <input type="button" value="🔍"/>
	* Account Number: <input style="width: 80%;" type="text"/> <input type="button" value="🔍"/>
	* Object Code: <input style="width: 80%;" type="text"/> <input type="button" value="🔍"/>
	Fiscal Year: <input style="width: 80%;" type="text" value="2013"/> <input type="button" value="🔍"/>
	Active Indicator: <input type="checkbox"/>

Search Results

The system returns a list of funds with balance, encumbrance and expense information. There is no drilldown available from this inquiry. Below is only a small sampling of results.

<u>Chart Code</u>	<u>Account Number</u>	<u>Account Name</u>	<u>Organization Code</u>	<u>Object Code</u>	<u>Cash balance</u>	<u>Free Balance</u>	<u>Initial Budget Allocation</u>	<u>Net Allocation</u>	<u>Encumbrances</u>	<u>Sum Paid Invoices</u>	<u>Sum In</u>
BL	PBRDAFE	Brodie African Studies E-books	LACQ	EBOK	0.00	0.00	0.00	0.00	0.00	0.00	0.00
BL	PBRDAFE	Brodie African Studies E-books	LACQ	EBOK	0.00	0.00	0.00	0.00	0.00	0.00	0.00
BL	PBRDAFE	Brodie African Studies E-books	LACQ	EBOK	0.00	0.00	0.00	0.00	0.00	0.00	0.00
BL	PBRDAFE	Brodie African Studies E-books	LACQ	EBOK	0.00	0.00	0.00	0.00	0.00	0.00	0.00
BL	PBRDAFE	Brodie African Studies E-books	LACQ	EBOK	0.00	0.00	0.00	0.00	0.00	0.00	0.00
BL	PBRDAFE	Brodie African Studies E-books	LACQ	EBOK	0.00	0.00	0.00	0.00	0.00	0.00	0.00

Flexible Offset Options

OLE uses the Offset Generation table inherited from KFS to generate appropriate offsets for transactions. This table indicates the object code used in offset generation, based on the transaction's chart, fiscal year, document type, and the balance type it affects. Offsets are generated automatically by a OLE e-doc or in 'Scrubber' during GL processing (i.e. batch jobs).

Normally, offsets are applied to the same account as the transaction that generated the offset. But OLE has a flexible offset feature that allows institutions to have offset entries applied to different accounts. This OLE feature includes two functions:

- Flexible banking offset
- Flexible offsets by account

Note

Offsets and full General Ledger functions in OLE will continue to be reviewed with Select & Acquire teams as we continue to build queries and budget functionality.

Flexible Banking Offsets

Document types that require a user to specify a bank account number (such as the Advance Deposit or Credit Card Receipt documents) can apply offset entries to a special account associated with this bank account number. If the `ENABLE_BANK_SPECIFICATION_IND` parameter is set to 'Y,' an additional set of cash entries is created to a designated accounting string (chart, account, sub-account, object code, and sub-object code) defined in the Bank document. These entries occur in addition to the normally generated cash offsets created to balance a set of transactions. In effect, they reclassify the generic cash entry to a bank-specific cash entry for reconciliation and tracking purposes. If the `ENABLE_BANK_SPECIFICATION_IND` parameter is set to 'N,' the normal balancing cash entries are created but the reclassification of cash to a bank-specific entry is not performed.

This option allows the user to specify the document types on which a bank code should appear. This information, which is specified in the `BANK_CODE_DOCUMENT_TYPES` parameter, allows you to specify bank information on additional document types that create disbursements or record revenue. A default Bank Code value should be established for each document type by using the `DEFAULT_BANK_BY_DOCUMENT_TYPE` parameter.

Flexible Offsets by Account

This option allows OLE to redirect offset entries for an account to another specified account. It allows OLE to accommodate tracking offsets such as cash or liabilities in central designated accounts as opposed to tracking such offset entries in every account. The Offset Account document identifies the offset account for an object code and account number combination.

If the offsets by account option is enabled within the parameter `USE_FLEXIBLE_OFFSET_IND`, OLE goes through a special process in e-docs and in 'Scrubber' during GL processing to determine the account that the offsets should be made to for a given transaction.

When the flexible offsets function is enabled, generation of offsets on e-docs occurs as follows:

5. The offset object code is defined in the Offset Definition table.
6. The object code and account number are searched from the Offset Account table.
7. If a match is found in the Offset Account table, the offset is made in the offset account defined there.
8. If no match is found, the offset is made in the same account on which the original transaction occurred.

Generation of offsets in 'Scrubber' when the flexible offsets function is enabled occurs as follows:

9. 'Scrubber' looks up the document type for a transaction in the Document Type table.
10. 'Scrubber' checks the document type of the entry against the document types defined in the parameter.
 - `OFFSET_GENERATION_DOCUMENT_TYPES`: If the document type is found in this parameter, 'Scrubber' does not generate offsets for this entry. This ensures that document types that should not generate offset entries (like journal voucher) do not have offsets generated during 'Scrubber' processing.
 - `DOCUMENT_TYPES_REQUIRING_FLEXIBLE_OFFSET_BALANCING_ENTRIES`: If the document type is found in this parameter, 'Scrubber' generates offsets even if the document type

appears to be balanced. This allows 'Scrubber' to generate the proper flexible offsets for transactions that originate outside of OLE.

- 11.If you are using flexible offsets (parameter USE_FLEXIBLE_OFFSET_IND is set to 'Y'), 'Scrubber' checks the document type against those found in the parameter.
- 12.If 'Scrubber' determines in the previous steps that an offset is to be generated, it determines the transaction's offset object code using the Offset Definition table.
- 13.If you are using flexible offsets (parameter USE_FLEXIBLE_OFFSET_IND is set to 'Y'), 'Scrubber' searches for the object code and account number in the Offset Account table.
- 14.If a match is found in the Offset Account table, the offset is made in the offset account defined there. If no match is found, the offset is made in the same account on which the original transaction occurred.

Budget Adjustment Search

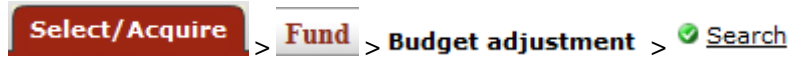

OLE offers a customized document search related to budget adjustments. The search screen contains the standard search fields along with special fields that are unique to this type of e-doc.

Note

For information about performing a search for one or more requisitions, see [Performing Acquisition Searches](#) on the *OLE E-Doc Fundamentals* wiki page.

Note

For information about Document lookup fields that are specific to requisitions, see “Document Layout” under [Requisition](#).

Budget Adjustment

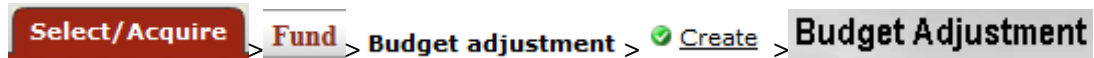

The Budget Adjustment (BA) document is used to record income and expense transactions not processed through other e-docs, against an existing budget. It can be used to modify a base budget, a current budget or both. It is a financial planning tool that allows an organization to adjust the current and base budget figures for a given account as circumstances may change throughout the fiscal year. It may be used to create a budget for a new account established after the beginning of a new fiscal year.

- Base budgets are established during the budget construction process, and designate an ongoing fiscal commitment.
- Current budgets designate budgetary authority for the current fiscal year.
- A BA document is normally used to:
 - reallocate current budget as necessary throughout the fiscal year
 - transfer funds from one general fund account to another
 - establish budget lines in new accounts created after the fiscal year begins

- make long-term adjustments to the base budget
- The document allows for the establishment of monthly budgeted amounts for users that wish to maintain budget information at this level.

Note

Budget Adjustments continue to be reviewed for OLE use.

Document Layout

The BA document only has the standard financial transaction document tabs and does not have any unique tabs. Two field exceptions are the **Year** field in the **Document Overview** tab and the **Monthly Lines** section in the **Accounting Lines** tab, which are explained later in this section.

Note

For more information about the standard tabs, see [Standard Tabs](#) on the *OLE E-Doc Fundamentals* wiki page.

Budget Adjustment ?

Doc Nbr: 3
Initiator: k

Document Overview
▼ hide

Document Overview

* Description:

Org. Doc. #:

Explanation:

Financial Document Detail

* Year: 2009 refresh

Accounting Lines
▼ hide

Accounting Lines ?

From/Decrease		* Chart Code		* Account Number	Sub-Account Code	* Object Code	Sub-Object Code	Project Code	Organization Reference Id	Current Amt
add:	▼	<input type="text"/>	<input type="text"/>	<input type="text"/>	<input type="text"/>	<input type="text"/>	<input type="text"/>	<input type="text"/>	<input type="text"/>	0.00
Monthly Lines ▶ show										

To/Increase		* Chart Code		* Account Number	Sub-Account Code	* Object Code	Sub-Object Code	Project Code	Organization Reference Id	Current Amt
add:	▼	<input type="text"/>	<input type="text"/>	<input type="text"/>	<input type="text"/>	<input type="text"/>	<input type="text"/>	<input type="text"/>	<input type="text"/>	0.00
Monthly Lines ▶ show										

General Ledger Pending Entries ▶ show

Notes and Attachments (0) ▶ show

Ad Hoc Recipients ▶ show

Route Log ▶ show

submit save blanket approve close cancel copy

Document Overview Tab

The **Document Overview** tab includes one unique field called **Year**.

BA Document Overview tab definition

Title	Description
Year	Required. Select the fiscal year this adjustment should apply to from the Fiscal Year list. Most budget adjustments are made to the current fiscal year but in some cases you may be able to choose a fiscal year that has not yet begun.

If you change the fiscal year, click  to make sure that all the fields on the document are available for that fiscal year. For example, you might not be able to do base budget changes to a particular fiscal year. Clicking **refresh** assures that the system disables fields that aren't valid for that year.

Accounting Lines Tab

The **Accounting Lines** tab in the BA document is also different from the other financial transaction documents in that it has the **Monthly Lines** section that can be expanded by clicking **show**.

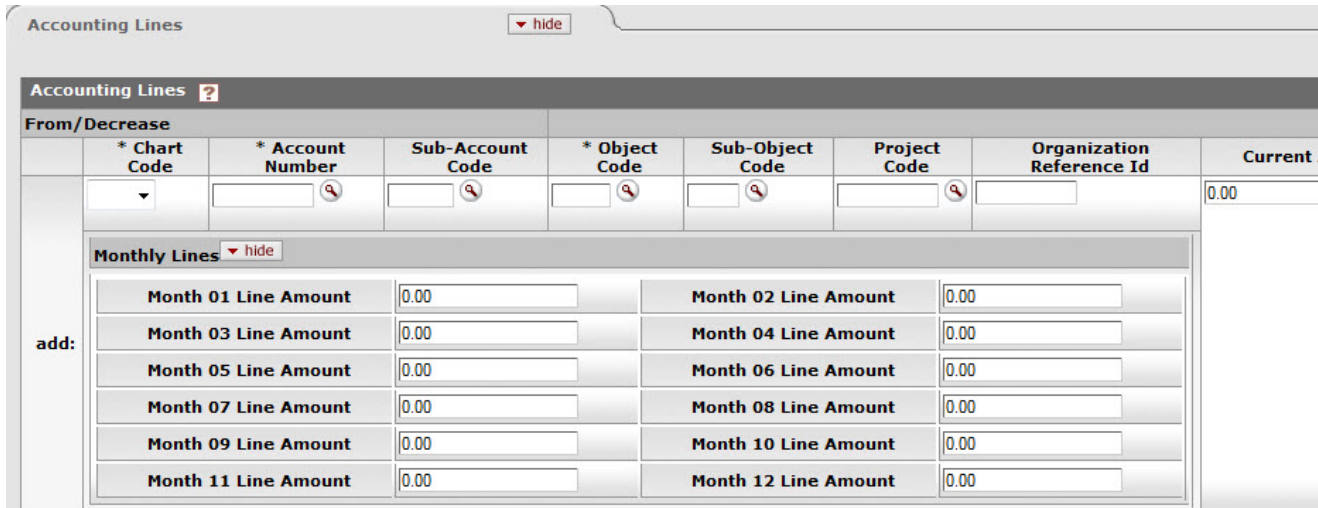

The screenshot shows the 'Accounting Lines' tab with a 'hide' button. Below the tab title is a 'From/Decrease' section with fields for * Chart Code, * Account Number, Sub-Account Code, * Object Code, Sub-Object Code, Project Code, and Organization Reference Id. A 'Current' field shows 0.00. Below this is a 'Monthly Lines' section with a 'hide' button and a table for monthly line amounts:

Monthly Lines	
Month 01 Line Amount	0.00
Month 02 Line Amount	0.00
Month 03 Line Amount	0.00
Month 04 Line Amount	0.00
Month 05 Line Amount	0.00
Month 06 Line Amount	0.00
Month 07 Line Amount	0.00
Month 08 Line Amount	0.00
Month 09 Line Amount	0.00
Month 10 Line Amount	0.00
Month 11 Line Amount	0.00
Month 12 Line Amount	0.00

To distribute an accounting lines current budget amount into monthly periods, click  on the **Monthly Lines** section.

This opens a series of twelve monthly periods where you can specify how much of the current amount for this account line should be distributed to each month. The total of all monthly distributions must equal the total current amount for this accounting line.

Use of the **From/Decrease** section automatically decreases the budget associated with the account, sub-account, and object code combination entered. The current budget, base budget, or both may be affected.

Use of the **To/Increase** section automatically increases the budget associated with the account, sub-account, and object code combination entered. The current budget, base budget, or both may be affected.

Note

The **From/Decrease** and **To/Increase** sections do not contain totals. Increases and decreases must balance in the document with relation to object code types in order to route the document.

This rule applies to the **From** and **To** sections affecting the current changed amount(s) and the **From** and **To** sections affecting the base changed amount(s).

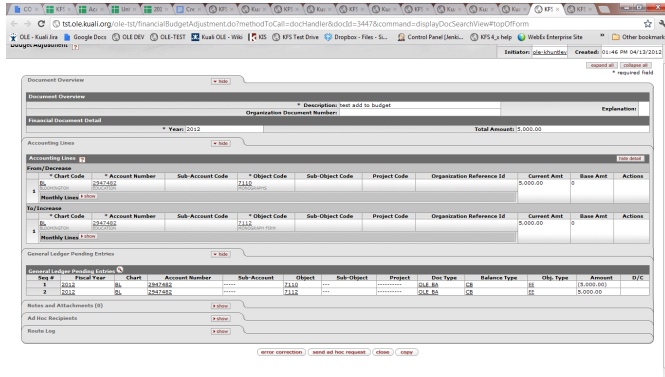

Tip

Try This Budget Setup:

1. Instead of typing in many accounting detail lines, users can use the BA spreadsheet template via the “Import Lines” option.
2. Simply fill in all accounting lines with required Chart, Account, Object, and Amounts
3. Import into the BA (or Transfer) documents in lieu of manual typing.

[BA-YEBA Import](#) template

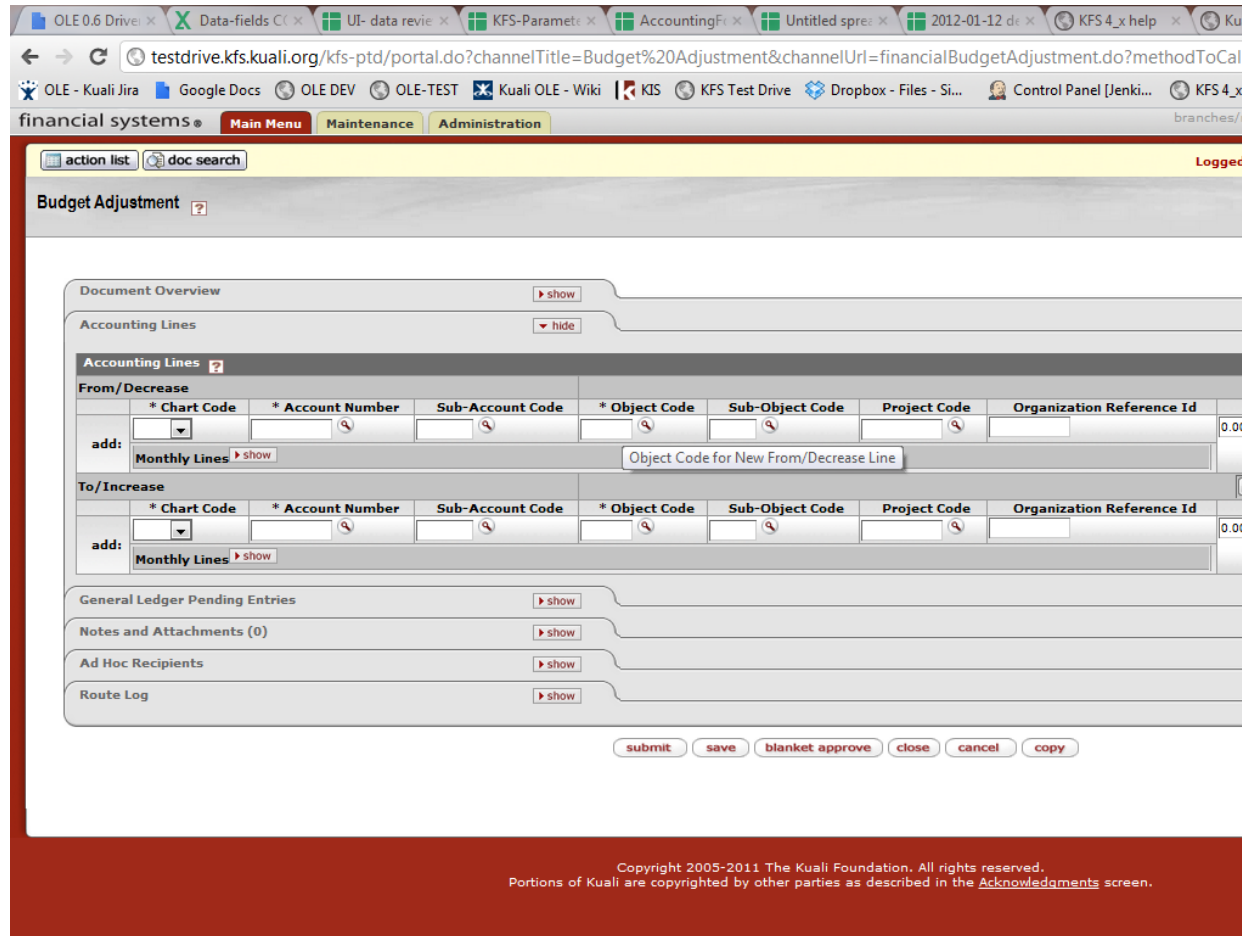

4. Click **submit** or **blanket approve**.

5. Review the **General Ledger Pending Entries** tab.

Document Overview

Document Overview

* Description: test add to budget

Organization Document Number:

Financial Document Detail

* Year: 2012

Accounting Lines

Accounting Lines

From/Decrease

	* Chart Code	* Account Number	Sub-Account Code	* Object Code	Sub-Object Code	Project Code	Organization Refer
1	BL BLOOMINGTON	2947482 EDUCATION		7110 MONOGRAPHS			

Monthly Lines [show](#)

To/Increase

	* Chart Code	* Account Number	Sub-Account Code	* Object Code	Sub-Object Code	Project Code	Organization Refer
1	BL BLOOMINGTON	2947482 EDUCATION		7112 MONOGRAPH FIRM			

Monthly Lines [show](#)

General Ledger Pending Entries

General Ledger Pending Entries

Seq #	Fiscal Year	Chart	Account Number	Sub-Account	Object	Sub-Object	Project	Doc Type	B
1	2012	BL	2947482	-----	7110	---	-----	OLE BA	CB
2	2012	BL	2947482	-----	7112	---	-----	OLE BA	CB

Notes and Attachments (0) [show](#)

Ad Hoc Recipients [show](#)

Route Log [show](#)

[error correction](#) [send ad hoc request](#) [close](#) [copy](#)

6. Review the **Route Log** tab.
7. The document is routed to the fiscal officer for each account used in the Accounting Lines. The Route Status shows 'ENROUTE'.
8. Appropriate fiscal officers and organization reviewers approve the document.

Income Stream Adjustments

If a Budget Adjustment involves two or more accounts with different Income Stream Accounts, OLE can be configured to create an automated Transfer of Funds transaction to properly adjust cash between those Income Stream accounts. This Transfer of Funds is generated by OLE after the Budget Adjustment is approved and does not route for approval itself.

Process Overview

Business Rules

- Only accounts that have the recording level attribute of 'Budget' accept budget adjustment transactions. The budget adjustment document cannot be used on a cash control (non-budgeted) account.

- Negative amounts are not allowed except when using the **Error Correction** option.

Note

For information about the error correction, see [Correcting Errors after Approval](#) on the *OLE Workflow Overview and Key Concepts* wiki page.

- Increases and decreases must balance in the document with relation to object code types. Increases in income may be balanced by decreases in other income lines or by increases in expenditures. Decreases in income may be balanced by increases in other income lines or by decreases in expenditures. Similar logic applies to changes in expenditures
- If Base Adjustments have not been enabled for the selected Fiscal Year on the document then base changes are not allowed.
- The fund group and sub-fund group attributes on an account contain an attribute (Budget Adjustment Restriction Code – BARC) for determining how budget adjustments within that group can be made. These attributes limit the mixing of accounts on the same BA documents.
- BARC values for fund group are: **C** (Chart), **O** (Organization), **A** (Account), or **F** (Fund).
- BARC values for sub-fund group are: **C** (Chart), **O** (Organization), **A** (Account), **S** (Sub-Fund), or **N** (None).
- If the BARC value of the sub-fund group is none, the BARC value of the sub-fund group's parent fund group applies to the account.
- The budget adjustment applies the following rules using these values:
 - If an account on the BA has an effective BARC of Account, then no other account can be used on that Budget Adjustment document, i.e. all adjustments (increases/decreases) must be to the same account.
 - If an account on the BA has an effective BARC of Organization, then the only other accounts on that Budget Adjustment document must belong to the same Organization, i.e. allowing adjustments among accounts in the same organization.
 - If an account on the BA has an effective BARC of Chart, then the only other accounts on that Budget Adjustment document must belong to the same Chart, i.e. allowing adjustments across accounts belonging to different Organizations but within the same Chart.
 - If an account on the BA has an effective BARC of Sub-Fund, then the only accounts on that Budget Adjustment document must belong to the same Sub-Fund Group, i.e. allowing adjustments across accounts belonging to different Organizations and Charts but with the same Sub-Fund Group Code.
 - If an account on the BA has an effective BARC of Fund, then the only accounts on that Budget Adjustment document must belong to the same Fund Group, i.e. allowing adjustments across accounts belonging to different Organizations and Charts and Sub-Fund Groups but with the same Fund Group Code.

The use of certain balance sheet object codes and certain object sub-types may be prohibited according to your institution's business rules.

Routing

The BA document is approved as final by the initiator if the following conditions are met:

- The document only adjusts a single account

- The document only adjusts current budget amount
- The Initiator is the fiscal officer for the account
- The total decrease amount is not greater than the current budget balance for the object code being decreased
- If previous conditions are not met, the document continues with standard financial document routing, based on the account numbers used on the document as follows:
 - The fiscal officer for each account must approve.
 - Organization review routing occurs for the organization that owns each account.
 - Sub-fund routing occurs based on the sub-fund of each account.

The document status becomes 'FINAL' when the required approvals are obtained and the transaction is posted to the G/L during the next G/L batch process.

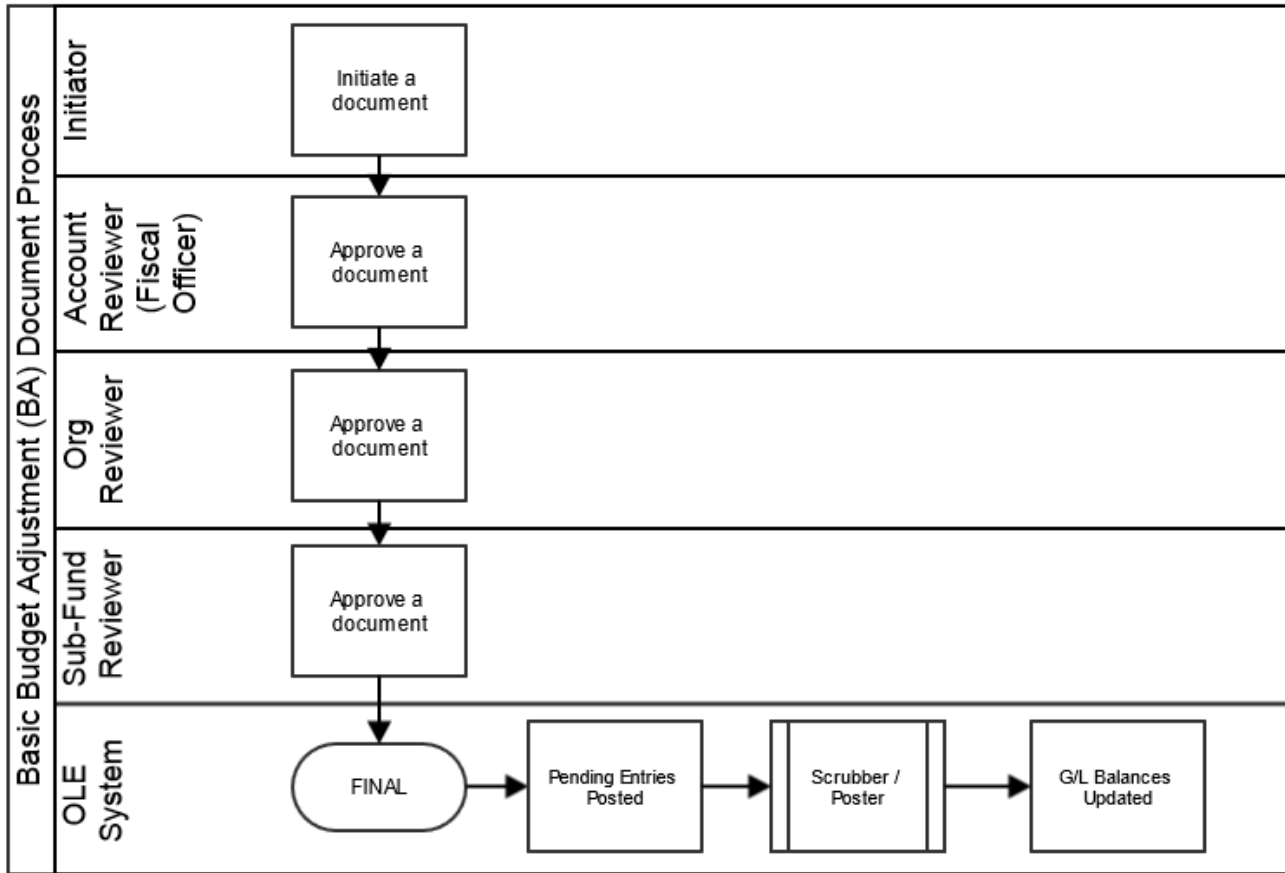

Initiating a Budget Adjustment Document

9. Select **Budget Adjustment** from the **Financial Transactions** menu.

A blank BA document with a new document ID appears.

10. Complete the standard tabs.

Note

For information about the standard tabs such as **Document Overview**, **Notes and Attachments**, **Ad Hoc Recipients**, **Route Log**, and **Accounting Lines** tabs, see [Standard Tabs](#) on the *OLE E-Doc Fundamentals* wiki page.

11. Click .

The document is routed to the fiscal officers of the accounts as well as any approvers in the Organizational Review hierarchy.

12. Review the **General Ledger Pending Entries** tab.

13. Review the **Route Log** tab.

Note

For information about the Route Log tab, see [Route Log](#) on the *OLE Workflow Overview and Key Concepts* wiki page.

14. Appropriate fiscal officers and organization reviewers approve the document.

Note

For more information about how to approve a document, see [Workflow Action Buttons](#) on the *OLE Workflow Overview and Key Concepts* wiki page.

Transfer of Funds Search

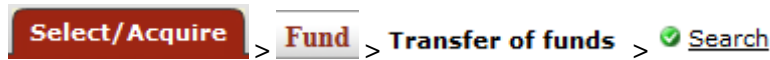

OLE offers a customized document search related to transfer of funds. The search screen contains the standard search fields along with special fields that are unique to this type of e-doc.

Note

For information about performing a search for one or more requisitions, see [Performing Acquisition Searches](#) on the *OLE E-Doc Fundamentals* wiki page.

Note

For information about Document lookup fields that are specific to requisitions, see “Document Layout” under [Requisition](#).

Transfer of Funds



Cash: In Libraries, we often think of cash/actuals as a summary of available balances, however in OLE/KFS, we have the options to manage both sides of accounting- expenses/liabilities and Cash. While General

Ledger and Transfer of Funds functions are noted here, we may/may not use Transfer of Funds or other GL correction documents inherited from KFS in adoptable OLE 1.0. The reason for this is simple (and complex): Libraries don't really operate from 'cash' but from budgets, as the university financial systems manage the actuals/cash and report back to libraries.

In OLE 1.0 and 1.5, we will be reconciling university financial integrations and OLE's use of Budget vs. Actual (cash) balances.

The Transfer of Funds (TF) document is used to transfer funds (cash) between accounts. The TF could be used to cover an overdraft, reimburse an account for an expense, or to fulfill a funding commitment.

Document Layout

The TF document has only the standard financial transaction document tabs and does not have any unique tabs of its own.

Note

For information about the standard tabs such as **Document Overview**, **Notes and Attachments**, **Ad Hoc Recipients**, **Route Log**, and **Accounting Lines** tabs, see [Standard Tabs](#) on the *OLE E-Doc Fundamentals* wiki page.

The screenshot displays the 'Transfer Of Funds' document interface. At the top, there is a header bar with the title 'Transfer Of Funds' and a help icon. To the right, there are fields for 'Doc Nbr:' and 'Initiator:'. Below this, the 'Document Overview' tab is active, showing fields for '* Description:', 'Org. Doc. #:', and 'Explanation:'. The 'Financial Document Detail' tab is also visible. The 'Accounting Lines' tab is expanded, showing a table with columns for 'From' and 'To' sections, including fields for '* Chart', '* Account Number', 'Sub-Account', '* Object', 'Sub-Object', 'Project', and 'Org Ref Id'. Below the accounting lines, there are tabs for 'General Ledger Pending Entries', 'Notes and Attachments (0)', 'Ad Hoc Recipients', and 'Route Log', each with a 'show' button. At the bottom, there are buttons for 'submit', 'save', 'close', 'cancel', and 'copy'.

Process Overview

Business Rules

- There must be at least one accounting line in the **From** section and one accounting line in the **To** section.

- The total in the **From** section must equal the total in the **To** section in the **Accounting Lines** tab.
- \$0 accounting line amounts are not allowed.
- Negative amounts are not allowed (unless it is an Error Correction TF).
- OLE automatically generates cash object code offset entries as defined by the information entered into the document.
- Object codes representing assets, liabilities, and fund balances (as indicated by the object code's object consolidation) may not be used.
- The Object code restrictions are as follows.

Restricted object type code in the Transfer of Funds document

Object Type Codes	Description	Restrictions
ES	Expense Not Expenditure	Unallowable
IC	Income Not Cash	Unallowable

- The object sub-types used must be sub-types of mandatory transfers and non-mandatory transfers.
- **From** accounting lines with an object sub-type of mandatory transfer must balance with **To** accounting lines with an object sub-type of 'Mandatory Transfer'.
- **From** accounting lines with an object sub-type of non-mandatory Transfer must balance with **To** accounting lines with an object sub-type of 'Non-Mandatory Transfer'.

Routing

The document routes based on the account numbers used on the document as follows:

- The fiscal officer for each account must approve.
- Organization review routing occurs for the organization that owns each account.
- Sub-fund routing occurs based on the sub-fund of each account.

The document status becomes 'FINAL' when the required approvals are obtained and the transaction is posted to the G/L during the next G/L batch process.

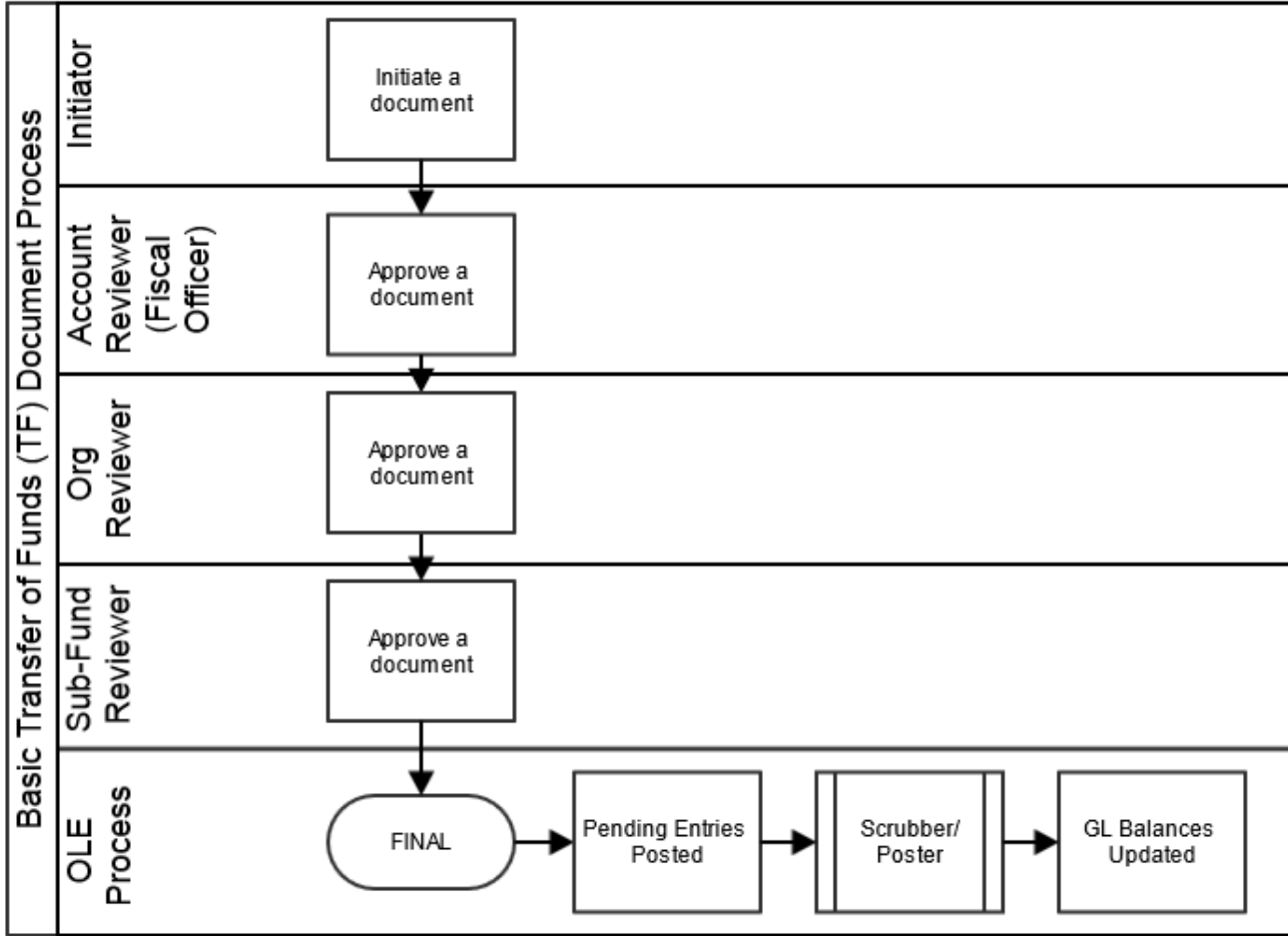

Initiating a Transfer of Funds Document

15. Select **Transfer of Funds** from the **Financial Processing** submenu group in the **Transactions** submenu on the **Main Menu** tab.

A blank TF document with a new document ID appears.

16. Complete the standard tabs.

All accounting lines in the **To** section generate credits and all accounting lines in the **From** section generate debits.

Note

For information about the standard tabs such as **Document Overview**, **Notes and Attachments**, **Ad Hoc Recipients**, **Route Log**, and **Accounting Lines** tabs, see [Standard Tabs](#) on the *OLE E-Doc Fundamentals* wiki page.

- a. Use sample Accounts & Objects in the [Appendix](#), such as moving \$\$ from Account 2947496 to 2947490 (note: using Non-Mandatory Object Sub-Type, TN, with specialized Object Codes for Transfer In and Transfer Out)

Transfer Of Funds ?

Document Overview ▼ hide

Document Overview

* **Description:** test-transfer KG

Organization Document Number:

Financial Document Detail

Total A

Accounting Lines ▼ hide

Accounting Lines ?

From						
	* Chart	* Account Number	Sub-Account	* Object	Sub-Object	Proj
1	BL BLOOMINGTON	2947496 SOCIOLOGY		1699 TRANSFER IN		

To						
	* Chart	* Account Number	Sub-Account	* Object	Sub-Object	Proj
1	BL BLOOMINGTON	2947490 SPEECH AND HEARING		9900 TRANSFER OUT		

General Ledger Pending Entries ▶ show

Notes and Attachments (0) ▶ show

Ad Hoc Recipients ▶ show

Route Log ▶ show

error correction
send ad hoc request
close
copy

b. Or from Accounts 2947486 to 2948482 (both of object code 7112 Monographs, with object sub-type of TN-Non Mandatory Transfer)

17. Click **submit**.

18. Review the **General Ledger Pending Entries** tab.

The pending entries include the offset generation to cash or fund balance object codes.

19. Review the **Route Log** tab.

The document is routed to the fiscal officer for each account used in the Accounting Lines. The Route Status shows 'ENROUTE'.

Note

For more information about the Route Log, see For information about the Route Log tab, see [Route Log](#) on the *OLE Workflow Overview and Key Concepts* wiki page.

20. Appropriate fiscal officers and organization reviewers approve the document.

Note

For more information about how to approve a document, see [Workflow Action Buttons](#) on the *OLE Workflow Overview and Key Concepts* wiki page.

Chapter 7. Acquisitions: Standard Transactional Documents

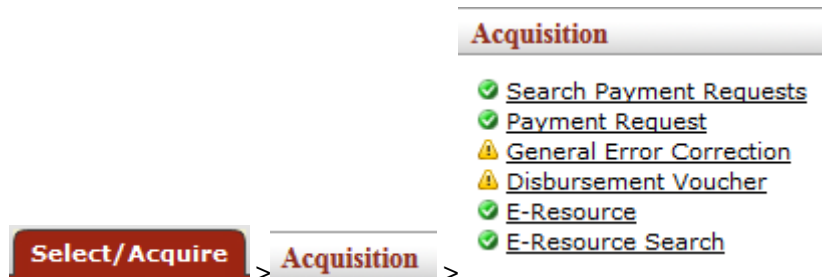

On the Select/Acquire tab, the Acquisition submenu provides access for users to search and edit payment requests, create general error corrections and disbursement vouchers, and search and edit E-Resources.

Payment Request Search



OLE offers a customized document search related to payment requests. The search screen contains the standard search fields along with special fields that are unique to this type of e-doc.

Note

For information about performing a search for one or more payment requests, see [Performing Acquisition Searches](#) on the *OLE E-Doc Fundamentals* wiki page.

Note

For information about Document lookup fields that are specific to payment requests, see “Document Layout” under [Payment Request](#).

Payment Request

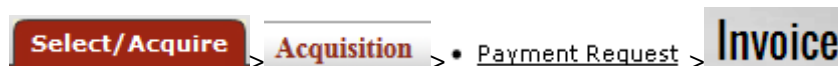

Note

In order for users to submit the Payment Request document, the `ENABLE_BANK_SPECIFICATION_IND` parameter must be set to Y and the `DEFAULT_BANK_BY_DOCUMENT_TYPE` parameter must be completed. Even if your institution is not planning to use the Bank Offset feature in Quali OLE, the `DEFAULT_BANK_BY_DOCUMENT_TYPE` parameter must be completed if your users plan to use the Payment Request document. Bank offsets will not be created if the Bank Offset feature has not been configured.

The Payment Request (PREQ) document is created in response to receiving an invoice for goods or services requested from a vendor on a PO. The system provides two ways of creating a payment request:

- One is automated through the electronic invoicing process. This will be reviewed for 1.0.
- The other approach is to complete the Payment Request document manually using the screen described in this section.

Getting Started

OLE breaks down vendor invoicing permissions into several roles. To create unapproved invoicing and payment requests, please sign into OLE as:

Role	Login
Receiving-AQ3	ole-durbin
Receiving-AQ4	ole-cstan
Accounting-AQ2, -AQ3, -AQ4	ole-cphovis, ole-earley, ole-ejacob
Super user	ole-khuntley (can do all)

Note

For OLE 1.0, we have not yet coded full university financial integrations. To “stub” this functionality at present, and to simulate how general ledger, fund/account updates, and expenses might be approved and processed through the university financial system, all payment requests stop at the relevant Fiscal/Accounts staff for final routing/export/batch processing.

Role	Login
Fiscal officer	ole-rorenfro
Fiscal manager	ole-jaraujo

Search for Purchase Order Numbers

Before initiating a payment request, you’ll need to know the purchase order number for the title(s) on your invoice. This can be found by doing an **Acquisitions Search** or a **Purchase Order Search**.

Note

To learn more about searching, see [Searching OLE](#) on the *OLE E-Docs fundamentals* wiki page.

Once you have the Purchase Ordernumber in hand for the title on your invoice, you can begin the payment process.

Tip

Be sure you have the Purchase Order number and not the system-generated document-identifier to initiate Payment Requests.

Document Layout

Two screens are associated with the Payment Request document—an 'initiation' screen with a single tab followed by a 'main' screen with multiple tabs.

Payment Request Initiation Tab

When you select **Payment Request** from the **Main Menu** tab, the system displays a screen containing the **Payment Request Initiation** tab.

Doc Nbr:	3969	Payment Request #:	Not Available
Initiator:	gle-khuntley	Payment Request S	

* Purchase Order #:	<input type="text"/>	* Invoice Number:	<input type="text"/>
* Invoice Date:	<input type="text"/>	* Vendor Invoice Amount:	<input type="text"/>
Special Handling Instructions:	<input type="text"/> <input type="text"/> <input type="text"/>	Foreign Vendor Invoice Amount:	<input type="text"/>

This tab allows you to specify details about the invoice and the PO to which it applies.

Payment Request Initiation tab definition

Title	Description
Purchase Order Number	Required. Enter the PO number to which the invoice applies.
Invoice Date	Required. Enter the invoice date from the vendor invoice or select the date from the calendar
Special Handling Instructions	Optional. Enter text into any of the special handling fields to indicate a special check delivery requirement for the payment.
Invoice Number	Required. Enter the identifying invoice number from the vendor invoice.
Vendor Invoice Amount	Required if the vendor is not foreign. Enter the net dollar amount of the invoice to be processed.
Foreign Vendor Invoice Amount	Required if the Vendor is foreign. Enter the net amount of the invoice to be processed.

Click to initiate this payment request. The system displays the main screen for the Payment Request document. It imports some information like vendor, line item details, accounting information, etc. from the relevant Purchase Order

Main Screen

Payment Request ?

	Doc Nbr:	3759
	Initiator:	gle-khuntley
	Payment Request #:	1062

Document Overview ▼ hide

Document Overview

* Description: PO: 1031 Vendor: YBP Library Services

Organization Document Number:

Explanation:

Financial Document Detail

* Year: 2013

Payment Request Detail

Receiving Required: No

Order Type: Firm, Fixed

Proforma:

Vendor ▶ show

Invoice Info ▼ hide

Invoice Info

* Invoice Number: ABC123

Pay Date: 04/29/2013 (Immediate Pay)

* Invoice Date: 04/01/2013

PO End Date:

Payment Attachment Indicator:

Extract Date:

Invoice Type:

* Bank Code: TEST
FIRST NATIONAL TEST BANK OF KUALI

* Purchase Order #: 1031

PO Notes: No

Payment Request Cost Source: ESTIMA

Payment Classification:

* Vendor Invoice Amount: 39.95

AP Processed Date:

Invoice SubType:

* Payment Method: Check

Process Items ▼ hide

Purchase Order Line Item Totals

Encumbrance excluding freight & s/h	Total Encumbrance Amount Relieved	Total Paid Amount
39.95	0.00	

Process Titles

Add Item

Item Line #	Open Qty	PO Unit/Ext Price	Format	Vendor Item Identifier	* No of Copies Ordered	* No. of Parts	* List Price	* Discount	Discount Type	Prorated Surcharge	* Unit Cost	Extended Cost	Assign To Tra In
					1	1	0.00	0.00	%				<input type="checkbox"/>

Bib Info: **Bib Editor** ▶ create new **Receipt Status**

Current Items

Item Line #	Open Qty	PO Unit/Ext Price	Format	Vendor Item Identifier	* No of Copies Ordered	* No. of Parts	List Price	Discount	Discount Type	Prorated Surcharge	Unit Cost	Extended Cost	Assign To Tra In
1		39.9500			1	1	39.95	0.00	%	0.0000	39.9500	39.95	No

1 **Bib Info:** **Bib Editor** ▶ edit **Receipt Status**

▶ show **Invoice Notes**

▶ show **Accounting Lines**

Invoice Total Prior to Additional Charges: 39.95

Additional Charges ▶ show

Grand Total: 39.95 Close PO

Account Summary ▶ show

View Related Documents ▶ show

View Payment History ▶ show

General Ledger Pending Entries ▶ show

Notes and Attachments (0) ▶ show

Ad Hoc Recipients ▶ show

Route Log ▶ show

calculate submit save reload blanket approve close

This screen includes unique **Document Overview**, **Vendor**, **Invoice Info**, **Process Items**, **Account Summary**, **View Related Documents**, and **View Payment History** tabs in addition to the standard tabs that display at the bottom of a financial transaction document.

Note

For more information about the standard tabs, see [Standard Tabs](#) on the *OLE E-Docs fundamentals* wiki page.

Document Overview Tab

The **Document Overview** tab for the Payment Request document is different from the standard **Document Overview** tab. The **Description** field defaults to the purchase order number and the vendor name.

On the Payment Request document, this tab is made up of three sections—**Document Overview**, **Financial Document Detail**, and **Payment Request Detail**. The **Document Overview** section is the same as the standard **Document Overview** tab.

Note

For information about the standard Document Overview tab, see [Standard Tabs](#) on the *OLE E-Docs fundamentals* wiki page.

Financial Document Detail Section

Financial Document Detail section definition

Title	Description
Year	Display-only. The fiscal year of the purchase order referenced by the Payment Request document.
Total Amount	Display-only. The total amount of the payment request after the request has been submitted.

Payment Request Detail Section

Payment Request Detail section definition

Title	Description
Receiving Required	Display-only. An indicator showing whether receiving is required.
Order type	Identifies the type of order, possible values could be one-time, standing, subscription. System default data value is "Firm, Fixed".
Proforma	Identifies whether the invoice is pre-paid. Check the box to indicate yes. This will override business rules requiring receiving before the payment request is approved and override payment terms associated with the vendor and set the invoice to "immediate pay" regardless of the invoice date.
Payment Request Positive Approval Required	Display-only. An indicator showing whether positive approval is required.

Vendor Tab

The **Vendor** tab contains information about the vendor associated with the PO and allows you to modify vendor address information.

Vendor Address	
* Vendor:	HARRASSOWITZ
Vendor #:	12111-0
* Address 1:	TAUNUSSTRASSE 5
Address 2:	
Attention:	
* City:	WIESBADEN
State:	
Province:	
Postal Code:	
* Country:	Germany
Vendor Info	
Acquisition Unit's Vendor account / Vendor Info Customer #:	
Check Stub Notes:	
Special Handling Instructions:	
Payment Terms:	Net 30 Day
Shipping Title:	
Shipping Payment Terms:	

The **Vendor** tab has two sections: **Vendor Address** and **Vendor Info**.

Vendor Address Section

Vendor Address section definition

Title	Description
Vendor	Display-only. The name of the vendor is automatically populated based on information in the purchase order.
Vendor Number	Display-only. The vendor number followed by a hyphen and the division number.
Address 1	Required. The default remit-to address is ordinarily populated from the Vendor document. The purchase order address will display here instead if there is not a remit-to address in the Vendor record. Override the default by entering a different address in this field or by searching for it from the Address lookup  .
Address 2	Optional. Override the default or leave it as is.
Attention	Optional. Override the default or leave it as is.
City	Required. Override the default or leave it as is.
State	Required for U.S. addresses. Override the default by selecting the state from the State list or leave it as is.
Province	Optional. Override the default or leave it as is.
Postal Code	Required for U.S. addresses. Override the default or leave it as is.
Country	Required. Override the default by selecting a country from the Country list or leave it as is.

Vendor Info Section

Vendor Info section definition

Title	Description
Acquisition Unit's Vendor Account/ Vendor Info Customer #	Optional. Populated from the PO. Override it by entering the customer number directly or searching for it from the vendor lookup  .
Check Stub Notes	Optional. Enter text to be printed on the check stub. This three line field allows for special notes to be printed on the check stub for the payment. Please note that entering a value into this field will force the system to create a physical check rather than an ACH transfer.

Acquisitions: Standard
Transactional Documents

Special Handling Instructions	Optional. Enter the handling instructions to be printed on the check. These handling instructions relate to the delivery of the check to the vendor. Please note that entering a value into this field will force the system to create a physical check rather than an ACH transfer.
Payment Terms	Optional. Populated from the PO. Override it by selecting the payment terms from the Payment Terms list.
Shipping Title	Display-only. This entry indicates when the items associated with a PO become the property of the ordering institution.
Shipping Payment Terms	Optional. Populated from the PO; identifies the entity that pays for shipping (the vendor or the institution). Override the entry by selecting the terms from the Shipping Payment Terms list.



Invoice Info Tab

The **Invoice Info** tab provides a means for display and modification of invoice information.

Invoice Info tab definition

Title	Description
Invoice Number	Display-only. Populated from the Payment Request Initiation tab.
Pay Date	Defaults to the date automatically calculated by the system. If payment terms are edited, the system repopulates this field only if it is blank. Override the automatic entry by entering a pay date or selecting it from the calendar  . Note Pay Date Calculations: The pay date is calculated automatically as follows. The payment terms specified are applied to the invoice date to generate a pay date. The payment terms parameters are in the Payment Terms Type table. Additionally, ten days (or another institutionally defined default number of days) are added to the current date to generate a pay date. KUALI OLE selects the later of these two dates and uses it as the default pay date for this Payment Request document. The pay date may be entered manually, but it must not be a past date. If the date is more than 60 days from the current date, the system displays a warning message.
(Immediate Pay)	Optional. Select the Immediate Pay check box if a check is needed on the same day (overrides the pay date – subject to the rules of your accounts-payable system). This indicator allows for an approved payment request to be extracted for payment during the day.
Invoice Date	Display-only. Populated from the Payment Request Initiation tab.
PO End Date	Display-only. The purchase order end date, if any, is automatically populated from the PO.
Payment Attachment Indicator	Optional. Select the check box if an attachment (such as a copy of the invoice) must be returned to the Vendor with this payment.
Extract Date	Display-only. The date the Payment record is extracted to the Pre-Disbursement Processor.

Acquisitions: Standard
Transactional Documents

Invoice Type	Optional. Select the type of invoice. Sample data values are Proforma/prepay, Regular.
Bank Code	Required. The bank code will be displayed only if the Bank_Code_Document_Types includes 'PREQ' and Enable_Bank_Specification_Ind='Y'. The default bank is determined by the Default_Bank_By_Document_Type parameter. You may override this value by entering another bank code or selecting it from the Bank  lookup.
Purchase Order Number	Display-only. The PO number associated with this invoice. This is the PO number used on the initiation screen.
PO Notes	Display-only. If notes have been added to the PO, this field contains the value 'Yes'.
Payment Request Cost Source	Display-only. Automatically populated from the PO if it exists.
Payment Classification	Display-only. Not currently used. In Kuali OLE the field will always be null. In a future enhancement, when wire transfer and foreign drafts are processed on Payment Request documents, this field will be populated.
Vendor Invoice Amount	Display-only. The vendor total invoice amount as entered on the Payment Request Initiation tab. This field is displayed only on an 'In Process' PREQ document. When the document is submitted, the system no longer carries the field and the value forward.
Foreign Vendor Invoice Amount	Display-only. The foreign vendor total invoice amount as entered on the Payment Request Initiation tab. This field is displayed only on an 'In Process' PREQ document. When the document is submitted, the system no longer carries the field and the value forward.
AP Processed Date	Display-only. The date the PREQ was submitted by an Accounts Payable processor.
Invoice Sub Type	Optional. Enter the subtype of invoice or select it from the Invoice Sub  Type lookup. Sample data values are Regular, Supplemental.
Payment Method	Select the method of payment from the drop down menu.

Process Items Tab

The **Process Itemstab** indicates the lines of the PO that this invoice relates to and the dollar amounts to be paid on this payment request. If a price was listed on the purchase order, that price is automatically supplied in the **Unit Cost** field. The tab also provides a means to edit accounting information associated with these lines and allows for the entry of additional invoiced items such as freight or shipping and handling. You should change the supplied price to the amount listed on your invoice, and supply the number of copies being invoiced.

Acquisitions: Standard
Transactional Documents

Process Items hide

Purchase Order Line Item Totals

Encumbrance excluding freight & s/h	Total Encumbrance Amount Relieved	Total Paid Amount
39.95	0.00	

Process Titles

Add Item

Item Line #	Open Qty	PO Unit/Ext Price	Format	Vendor Item Identifier	* No of Copies Ordered	* No. of Parts	* List Price	* Discount	Discount Type	Prorated Surcharge	* Unit Cost	Extended Cost
					1	1	0.00	0.00	%			
Bib Info:	Bib Editor	<input type="button" value="create new"/>	Receipt Status									

Current Items

Item Line #	Open Qty	PO Unit/Ext Price	Format	Vendor Item Identifier	* No of Copies Ordered	* No. of Parts	List Price	Discount	Discount Type	Prorated Surcharge	Unit Cost	Extended Cost
1	1	39.9500			1	1	39.95	0.00	%	0.0000	39.9500	39.95
1	Bib Info:	Bib Editor	<input type="button" value="edit"/>	Receipt Status								
	<input type="button" value="show"/>	Invoice Notes										
	<input type="button" value="show"/>	Accounting Lines										

Invoice Total Prior to Additional Charges:	39.95	
Additional Charges <input type="button" value="show"/>		
Grand Total:	39.95	<input type="button" value="Close PO"/>

The **Process Items** tab includes three sections: **Purchase Order Line Item Totals**, **Process Titles**, and **Additional Charges**.

Purchase Order Line Item Totals Section

Purchase Order Line Item Totals section definition

Title	Description
Encumbrance excluding freight & s/h	Display-only. The total dollar amount encumbered for this PO excluding freight, shipping and handling.
Total Encumbrance Amount Relieved	Display-only. The total dollar amount of the encumbrance that has thus far been relieved from this PO, excluding any additional charges processing.
Total Paid Amount	Display-only. The dollar amount total for line item payments excluding freight, shipping and handling, discount and miscellaneous payments made thus far against this purchase order. The difference in amounts between Total Encumbered Amount Relieved and Total Paid Amount is the difference between the PO unit cost and the payment request unit cost.

Process Titles Section

Items section definition

Title	Description
Item Line #	Display-only. The actual Item line number from this PO.
Open Qty	Display-only. The quantity of items that have yet to be invoiced for this line item.
PO Unit/Ext Price	Display-only. The cost per unit from the PO for this line item.
Format	Display-only. Identifies the Format for this line item.
Vendor Item Identifier	Display -only. Identifies a vendor item identifier if one has been provided by a vendor.
No of Copies Ordered	Required. Enter the number of copies of a title being invoiced. This entry reduces the open number of parts for this line item on the PO.

Acquisitions: Standard
Transactional Documents

No. of Parts	Required. Enter the parts of items being invoiced for this line. This entry reduces the open number of parts for this line item on the PO.
List Price	Basic price of an item before any discounts are taken.
Discount	Discount provided by the vendor/customer number/organization combination. Automatically populated from the Vendor customer number table based on the selected vendor and customer number. Can be modified for a specific title. If the vendor record has a Vendor currency noted other than the default system currency (aka US dollar), then the Vendor discount will populate the Foreign Discount field.
Discount Type	Choose # (for Amount) or % (for Percentage).
Prorate Surcharge	Additional charge applied to the line item based on the proportional distribution
Unit Cost	Optional The unit price for this line item as it appears on the invoice. This field is automatically populated using the price from the PO, but it may be changed if the invoice reflects a different price.
Extended Cost	If this field is blank and if the No of Copies Ordered is populated, the system calculates the extended cost for this line item when you click the calculate button. Note If the field already contains a value, you must delete the value in order to populate a new value by clicking calculate . Override the amount as needed.
Assigned To Trade In	Display-only. This 'Yes/No' indicator is based on the PO.
Description	Display-only. The title of the item, retrieved from the PO.
Currency Type	Display only. Identifies the associated vendor's currency as identified on the vendor record that is identified in the Link to Vendor/Supplier
Foreign List Price	Basic foreign price of an item before any discounts are taken.
Foreign Discount	Foreign discount provided by the vendor/customer number/organization combination when the vendor record has a Currency Type different from the system default currency. Should be automatically populated from the Vendor customer number table based on the selected vendor and customer number (PUR_VNDR_CUST_NBR_T: VNDR_CUST_NBR). This data can be changed for the specific title. Must identify the type of discount (amount or %.) If the vendor record does not have a Currency Type noted other than the default system currency (aka US dollar), then the discount should populate the Discount field.
Foreign Discount Type	Choose # (for Amount) or % (for Percentage).
Foreign Discount Amt	Foreign Discount Amount is a calculated value in the foreign currency
Foreign Unit Cost	Calculated foreign cost per unit for the item or service on this line. Calculation is the Foreign List Price less Foreign Discount amount.
Exchange Rate	Currency conversion rate populates from the Currency rate column in the Currency Type maintenance table (which is populated each night into system as Batch from bank files). The rate will populate when user clicks action button "Calculate" on conversion tab. Optionally: when currency tab opens, currency rate may auto-populate. This may be updated up until the Requisition is approved. After that point, it may no longer be modified.
<i>Bib Info</i>	If new item is invoiced, must be entered via the Bib Editor and a PO Amendment
Receipt Status	Select the status from the dropdown menu.
Invoice Total Prior to Additional Charges	Display-only. The calculated sum of the Total Amount fields of all the line items.

Modifying the Process Titles Tab

On a new, unsubmitted payment request, the Process Titles subsection of the Process Items tab will have two divisions. One line will be headed by the label "Add Item", and the next will be headed by the label "Current Items". The "Current Items" section may feature multiple lines, divided by item number, each with its own "Invoice Notes" and "Accounting Lines" sub tab. Both the line items and their accounting lines are automatically carried over from the purchase order preceding the current payment request.

Add New Line Items

It is possible to add additional titles or other miscellaneous line items which are listed on the invoice, even if they were not originally on the purchase order:

Users must complete the line item and linked bib in this sequential order. This will be fixed in future releases.

New line items:

- a. First click **create new** to launch the bib [editor](#) & save your data

Marc Editor

Leader:

001	68524d19-2bf1-4248-8148-93?	<input type="button" value="add tag"/>	<input type="button" value="remove tag"/>
008	Test description	<input type="button" value="add tag"/>	<input type="button" value="remove tag"/>
245		<input type="text" value=" aHistory of Libraries"/>	<input type="button" value="add tag"/> <input type="button" value="remove tag"/>
100		<input type="text" value=" aTimothy McGeary"/>	<input type="button" value="add tag"/> <input type="button" value="remove tag"/>

Note

For more information about the Bibliographic Editor, see Editors in the *Guide to Describe – DocStore and Editors*. This and other OLE user guides are available for download from the [OLE Documentation Portal](#).

- b. Add transactional data to the line (quantity, price, category etc.).
- c. After both are complete, click on **add** to save the line. This should update and link the bib and Description.
- d. Then depending on the document, finish with rest of edits, add accounting lines, **calculate**, **save** etc.
- e. After the **add** button is clicked, the Bibliographic information will show up in the Process Titles section.
To add accounting information to each of the items you have added, click the **show** button next to Accounting Lines:

Item 1									
1	Qty	1.00	EA EACH	1	EMIL NOLDE, EMIL SCHUMACHER : VERWANDTE SEELEN,NOLDE, EMIL, 1867-1956,COLOGNE DUMONT 2011,9783832193515	45.00		45.00	45.00
	Bib	<input type="button" value="view"/>	Requestor		HUNTLEY, KEISHA Y				
	Options	Format	Category			Item Price Source		Request Source	
	<input type="button" value="show"/>	Notes							
	<input type="button" value="show"/>	Accounting Lines							

Editing existing line items

Click on the button to edit the linked bib of the existing line item. When completed, you will be returned to your working purchasing document.

Note

You will not yet see your revised Description from the updated bib, until you complete further actions on the overall purchasing document, such as **save**, **submit**, or **blanket approve**. If you are only saving your doc, and wish to see Description updates, you may need to **save** or **save & reload** the e-Doc AFTER making updates in the bib- in order to update its description with linked bib changes-- prior to **submit** or **blanket approve**

Purchase Order Amendment Created

Above creates a Purchase Order Amendment (POA) document, with the new title added. The POA document is then routed according to the routing rules established in your system for POA approvals.

Note

Routing the Purchase Order Amendment from “unordered” line item during Payment Request is automatic from authorized receiving staff. The resulting POA must be edited by Acquisitions staff or managers, and Submitted. Please note a bug fix to complete the approval process. Olekhuntley can be used to complete the related Purchase Order Amendment and approve it.

Invoice Notes and Accounting Lines Section

Invoice Notes and Accounting lines, for fund accounting, are hidden beneath the Items section; they can be shown by clicking the button next to each:





Acquisitions: Standard
Transactional Documents

Current Items																																													
Item Line #	Open Qty	PO Unit/Ext Price	Format	Vendor Item Identifier	* No of Copies Ordered	* No. of Parts	List Price	Discount	Discount Type	Prorated Surcharge	Unit Cost	Extended Cost	Assigned To Trade In																																
1		39.9500			1	1	39.95	0.00	%	0.0000	39.9500	39.95	No																																
Bib Info:		Bib Editor	edit	Receipt Status																																									
<input type="checkbox"/> hide Invoice Notes																																													
Note: <div style="border: 1px solid gray; height: 30px; width: 100%;"></div>																																													
<input type="checkbox"/> hide Accounting Lines																																													
Accounting Lines ?																																													
<table border="1"> <thead> <tr> <th colspan="8">Source</th> </tr> <tr> <th>* Chart</th> <th>* Account Number</th> <th>Sub-Account</th> <th>* Object</th> <th>Sub-Object</th> <th>Project</th> <th>Org Ref Id</th> <th>* Dollar</th> </tr> </thead> <tbody> <tr> <td>BL</td> <td>2947430</td> <td></td> <td>7112</td> <td></td> <td></td> <td></td> <td>39.95</td> </tr> <tr> <td>BLOOMINGTON</td> <td>GEOLOGY</td> <td></td> <td>MONOGRAPH FIRM</td> <td></td> <td></td> <td></td> <td></td> </tr> </tbody> </table>														Source								* Chart	* Account Number	Sub-Account	* Object	Sub-Object	Project	Org Ref Id	* Dollar	BL	2947430		7112				39.95	BLOOMINGTON	GEOLOGY		MONOGRAPH FIRM				
Source																																													
* Chart	* Account Number	Sub-Account	* Object	Sub-Object	Project	Org Ref Id	* Dollar																																						
BL	2947430		7112				39.95																																						
BLOOMINGTON	GEOLOGY		MONOGRAPH FIRM																																										
Invoice Total Prior to Additional Charges:							39.95																																						
Additional Charges <input type="checkbox"/> show																																													
Grand Total:							39.95	<input type="checkbox"/> Close PO																																					

Invoice Notes section definition

Title	Description
Note	Optional. Free text note to include additional information about the invoiced item.

Accounting Lines section definition

Title	Description
Chart	Required. Select the chart code from the Chart list.
Account Number	Required. Enter the account number or search for it from the Account lookup  .
Sub-Account	Optional. Enter the sub-account number or search for it from the Sub-Account lookup  .
Object	Required. Enter the object code or search for it from the Object Code lookup  .
Sub-Object	Optional. Enter the sub-object code or search for it from the Sub-Object lookup  .
Project	Optional. Enter the project code or search for it from the Project lookup  .
Org Ref Id	Optional. Enter the appropriate data for the transactions.
Dollar \$	Display only. Calculated total dollar amount that will be applied to the Line Account.
Percent	Indicates the Percentage that will be applied to the Line Account. System default data value 100%.
Actions	Add or delete lines as appropriate.

Accounting lines are carried over from the purchase order related to the payment request. A new accounting line will be followed by an **add** action button, and existing accounting lines will be followed by both a **delete** action button and a **bal inquiry** action button.

Tip

If the account chosen has sufficient funds checking and the threshold is reached, you may be blocked from using the account or you may receive a warning (depending on the chosen notification on the account) when the document is saved and the Fiscal Officer will be notified when the document is submitted.

Charges can be shared among multiple funds by percentage. A blank line for adding an additional fund appears for each title, above the line/s already added:

Accounting Lines ?							
Source							
* Chart	* Account Number	Sub-Account	* Object	Sub-Object	Project	Org Ref Id	* Do
<input type="text"/>	<input type="text"/>	<input type="text"/>	<input type="text"/>	<input type="text"/>	<input type="text"/>	<input type="text"/>	<input type="text"/>
<input type="text"/>	<input type="text"/>	<input type="text"/>	<input type="text"/>	<input type="text"/>	<input type="text"/>	<input type="text"/>	<input type="text"/>
BL BLOOMINGTON	2947488 FOLKLORE	<input type="text"/>	0110 BALANCE FORWARD	<input type="text"/>	<input type="text"/>	<input type="text"/>	<input type="text"/>
BL BLOOMINGTON	2947491 HISTORY	<input type="text"/>	0110 BALANCE FORWARD	<input type="text"/>	<input type="text"/>	<input type="text"/>	<input type="text"/>

Additional Charges Section

The Additional Charges tab allows lines for predetermined charges to be included on the payment request. This tab is divided into four charge lines, each representing a different type of charge, each with its own accounting lines, and a series of options through which the amounts added in this section can be prorated to the existing line items in the Current Items sub tab. The four Additional Charges lines are **Freight**, **Shipping and Handling**, **Minimum Order**, and **Miscellaneous or Overhead**.

Additional Charges <input type="button" value="hide"/>				
* Item Type	Original Amount from PO	Outstanding Encumbered Amount	Extended Cost	Description
Freight				
Freight :	<input type="text"/>	<input type="text"/>	<input type="text"/>	<input type="text"/>
<input type="button" value="show"/> Accounting Lines				
Shipping and Handling				
Shipping and Handling :	<input type="text"/>	<input type="text"/>	<input type="text"/>	<input type="text"/>
<input type="button" value="show"/> Accounting Lines				
Minimum Order				
Minimum Order :	<input type="text"/>	<input type="text"/>	<input type="text"/>	<input type="text"/>
<input type="button" value="show"/> Accounting Lines				
Miscellaneous or Overhead				
Miscellaneous or Overhead :	<input type="text"/>	<input type="text"/>	<input type="text"/>	<input type="text"/>
<input type="button" value="show"/> Accounting Lines				
Grand Total:		39.95	<input type="checkbox"/> Close PO	

Each line contains these fields:

Acquisitions: Standard
Transactional Documents

Additional Charges section definition

Title	Description
Item Type	Display-only. The type of item to be charged.
Original Amount from PO	Display-only. The total extended amount of the additional charges for the item type on this PO.
Outstanding Encumbered Amount	Display-only. The outstanding encumbrance amount of the additional charges for the item type on this PO.
Foreign Currency Extended Cost	Displays the extended amount charged on the invoice for this additional charge item.
Currency Type	Display only. Identifies the associated vendor's currency as identified on the vendor record that is identified in the Link to Vendor/Supplier
Exchange Rate	Currency conversion rate populates from the Currency rate column in the Currency Type maintenance table (which is populated each night into system as Batch from bank files). The rate will populate when user clicks action button "Calculate" on conversion tab. Optionally: when currency tab opens, currency rate may auto-populate. This may be updated up until the Requisition is approved. After that point, it may no longer be modified.
Extended Cost	Displays the extended amount charged on the invoice for this additional charge item.
Description	Required for miscellaneous charges. A description is optional for freight charges, shipping and handling, and minimum order charges. Note The ITEM_TYPES_REQUIRING_USER_ENTERED_DESCRIPTION parameter controls whether the description is required or optional.

Additionally, each charge has an accounting line below it, so you can assign charges to your preferred fund:

Miscellaneous or Overhead

Miscellaneous or Overhead :

▼ hide **Accounting Lines**

Accounting Lines ?

Source	* Chart	* Account Number	Sub-Account	* Object	Sub-Object
	BL BLOOMINGTON	2947500 LIBRARY ACQUISITIONS GENERAL		7129 SERIAL SERVICE	

If you choose, you may also prorate the additional charges to the invoiced titles.

Enter the amount of the additional charge, select to prorate by **Quantity**, **Dollar**, or **Manual Prorate**. If Manual prorate is selected, enter the amount you would like prorated to each title.

Account Summary Tab

The Account Summary tab will summarize all accounts attached to the payment request and their respective charges after calculation. Information in the account summary is divided first by account, then by line item or additional charges line. Charges prorated to multiple accounts will be represented separately. Any changes made to accounting line items will not be updated until the PREQ has been calculated and the "Refresh Account Summary" button at the top of the tab has been clicked.

Click [refresh account summary](#) to reload the page and view all the fiscal years, accounting lines and dollar amounts for this requisition.

View Related Documents Tab

The **View Related Documents** tab collects information about Purchasing/AP documents related to this document. For example, it displays identifying information and any pertinent notes for associated requisitions, the purchase order, receiving documents, other payment requests for this PO, and credit memos. Within each document type the documents are listed in order, with the most recent first.



View Payment History Tab

The **View Payment History** tab tracks payment information related to the purchase order associated with this Payment Request document. It shows pending payment information and is updated automatically to show when a payment has been processed through the Pre-Disbursement Processor (PDP). This tab also shows any credit memos that have been processed against the related purchase order, including detail with an associated payment request referenced by the credit memo.

View Payment History										
Payment History - Payment Requests										
PREQ #	Invoice #	PO #	PREQ Status	Hold	Request Cancel	Vendor Name	Customer #	Amount	Pay Date	
1068	I-2	1063	Auto-Approved	No	No	DIVISION 1 OF PO BASIC		221.00	10/26/2009	2009-10-26
1067	I-1	1063	Department-Approved	No	No	DIVISION 1 OF PO BASIC		294.00	10/26/2009	2009-10-26

Payment History - Credit Memos										
CM #	Vendor CM #	PREQ #	PO #	Credit Memo Status	Hold	Vendor Name	Customer #	Amount	APAD Date	
1003	I-C-1	1067	1063	Complete	No	DIVISION 1 OF PO BASIC		100.00	10/26/2009	2009-10-26

Payment Requests Section

Payment Requests section definition

Title	Description
PREQ Number	Display-only. The payment request number.
Invoice Number	Display-only. The invoice number associated with this payment request.
PO Number	Display-only. The PO number associated with this payment request.
PREQ Status	Display-only. The status of the payment request.
Hold	Display-only. Displays 'yes' if the payment request is on hold. Displays 'no' if the payment request is not on hold.
Request Cancel	Display-only. Displays 'yes' if the payment request has been requested canceled. Displays 'no' if the payment request has not been canceled or if 'request cancel' has been removed.
Vendor Name	Display-only. The vendor name associated with this payment request.

Acquisitions: Standard
Transactional Documents

Customer Number	Display-only. The customer number associated with this payment request.
Amount	Display-only. The dollar amount associated with this payment request.
Pay Date	Display-only. The date the payment is scheduled to extract to the Pre-Disbursement Processor.
PDP Extract	Display-only. The date the payment request was extracted to the Pre-Disbursement Processor for disbursement processing.
Paid?	Display-only. Displays 'yes' if the payment has been disbursed. Displays 'no' if the payment has not been disbursed.

Credit Memos Section

Payment History tab, Credit Memos section definition

Title	Description
CM#	Display-only. The credit memo number assigned by the KUALI OLE.
Vendor CM#	Display-only. The credit memo number assigned by the vendor.
PREQ#	Display-only. The payment request number if a payment request was referenced in processing the credit memo.
PO#	Display-only. The purchase order number associated with this credit memo.
Credit Memo Status	Display-only. The status of the credit memo.
Hold	Display-only. Displays 'yes' if the credit memo is on hold. Displays 'no' if it is not on hold.
Vendor Name	Display-only. The vendor name associated with this credit memo.
Customer #	Display-only. The customer number associated with this credit memo.
Amount	Display-only. The dollar amount associated with this credit memo.
APAD Date	Display-only. The Accounts Payable approved date (that is, the date an Accounts Payable processor submitted the credit memo).
PDP Extract Date	Display-only. The date the credit memo was extracted to the Pre-Disbursement Processor for disbursement processing.
Paid?	Display-only. Displays 'yes' if the credit has been disbursed. Displays 'no' if it has not been disbursed.

Process Overview

Business Rules

- Partial payment/short-pay is allowed. Multiple payments against a PO or PO line item are allowed.
- Every payment request must be processed against a specific open PO document. This PO must be specified when the payment request is initiated.

Note

Under review for 1.0: Many to one Purchase Order to Invoice.

- If the vendor number and invoice number match values previously processed, a warning notifies the initiator of the potential duplicate. Even so, the system allows the initiator to override the warning and continue.
- If the invoice amount and invoice date match values previously processed for this vendor, a warning notifies the initiator of the potential duplicate. Even so, the system allows the initiator to override the warning and continue.
- Insufficient funds in the assigned budget will stop a payment from processing.

- Pay Date may not be a past date. If the pay date is more than 60 days in the future, a warning is received.
- Discounts applied from payment terms do not apply to freight or shipping and handling charges.
- Additional charges items that were not specifically funded on the purchase order are allocated to accounting lines in proportion to the item amounts on the purchase order if no allocation noted, else:
 - OLE offers prorating as form of incorporating additional charges within each line item unit cost.
- The **calculate** button must be pressed prior to submitting the payment request.
- Accounts Payable can close the PO during the processing of an invoice if the invoice will complete the order.
- The following G/L entries are created when the payment request is submitted.
 - Debit entry: The expense accounts (full accounting string) on the payment request are debited in the G/L when the initiator submits the document. The G/L entry is made in summary for each accounting string. Consequently, if three line items on a payment request use the same accounting string, only one debit (not three) is created in the G/L for that accounting string.)
 - Credit entry: One offset to object code 9041 is created for each account/sub-account combination on a payment request.
- During fiscal officer approval routing of the PREQ, the fiscal officer/PREQ delegate may edit the accounts/sub-account/object codes and amounts. The existing account string is reversed. The new account string debits the expense and credits object code 9041, the liability offset.
- After being canceled, the G/L entries are reversed, any disencumbrance created from AP submission of the payment request is reversed, and the PO open quantities that were decremented from the creation of the payment request are increased. Only authorized users may cancel a Payment Request document.
- Only authorized users may modify a payment request's pay date, attachment flag, special handling instructions, immediate pay flag, and check stub notes. This action may be taken at any point following AP submit and preceding extract to PDP.
- Payment request searches are available to all users.
- A payment request that is Hold = 'yes' or is Request Cancel = 'yes' does not continue through workflow routing and cannot be paid until the hold or request cancel is removed.
- If payment requests total less than the threshold established by the institution and do not have any accounts requiring positive approval, they may be automatically approved.

Tip

Sites not wishing to use this functionality can circumvent it by setting a very low threshold (as low as \$0.01 to effectively turn the feature off).

- After being extracted, a payment request cannot be put on hold.
- A payment request is extracted for payment if the following conditions are met:
 - The PREQ is department-approved or auto-approved.
 - The Pay Date is today or a prior date or 'immediate pay' is indicated and the payment has departmental approval.

- The payment is not Hold = 'yes'.
- If the payment request includes accounts that are excluded from auto-approval, it must be department-approved.

Routing

- An AP Processor selects the **submit** button to complete the processing of a payment request document. The document routes to 'Awaiting AP Review' status if Require_attachment_ind='Y'. The AP Review status may be satisfied by an image attachment or in another fashion (configurable at your institution). After AP review, the document routes for fiscal officer or fiscal officer delegate approval. At the AP Review routing level, approvers cannot change content on the document. They may only add notes/ attachments and approve or cancel.
- In addition to normal account review and organization review, the Payment Request document includes the following special condition routing:
 - Sub-Account Manager: An optional role that allows users to receive workflow action requests for documents that involve a specific account number and sub-account number. The role name is Sub-Account Reviewer. Approvers at this level may only approve, request cancel, and hold the document. They cannot change content.
 - Chart Approval: An optional role that allows users to receive workflow action requests for documents of a specified type that contain accounts belonging to a specified chart and organization (including the organization hierarchy) and within a certain dollar amount or involving a specified override code. The role name is Accounting Reviewer. Approvers at this level may only approve, request cancel, and hold the document. They cannot change content.

Post Processing

- Unlike other KUALI OLE documents, G/L entries for this document are created prior to final approval. Upon document submission to Workflow, disencumbrance entries and actual charges are generated, written to the G/L pending entry table, and posted in the nightly G/L batch cycle. If fiscal officers change accounting strings or redistribute the charges within their accounts, G/L entries are generated to reverse the original actual entries and recreate them (encumbrances are not altered) and these entries are written to the GL Pending table for posting in the next batch cycle.
- Upon document submission, PO line item details (open quantity, amount paid, etc.) are adjusted to reflect materials/services that have been paid.
- Upon document submission, the 'ap-approved' timestamp will be updated.
- If the department completes all of the approvals through Workflow, the payment request status is updated to 'Dept-Approved' during post-processing. If the document is automatically approved through the batch auto-approve script, its status is updated to 'Auto-Approved'.
- Canceling a payment request that has already received some level of approval will result in reversing G/L entries (encumbrances and actuals) and reversing updates to the PO line items affected (open quantity, amount paid, etc.).
- Once a payment request has been approved, an audit-trail entry is added to the request's **Route Log**.

The Timing of G/L Update: After a Payment Request document has been created and submitted, it updates the G/L the next time a batch process runs. Note that this timing is different from that of most KUALI OLE docs, which do not update the G/L until the document receives all approvals. If accounting

entries on the document change before it reaches 'Final' status, the G/L entries is updated accordingly the next time a batch process runs.

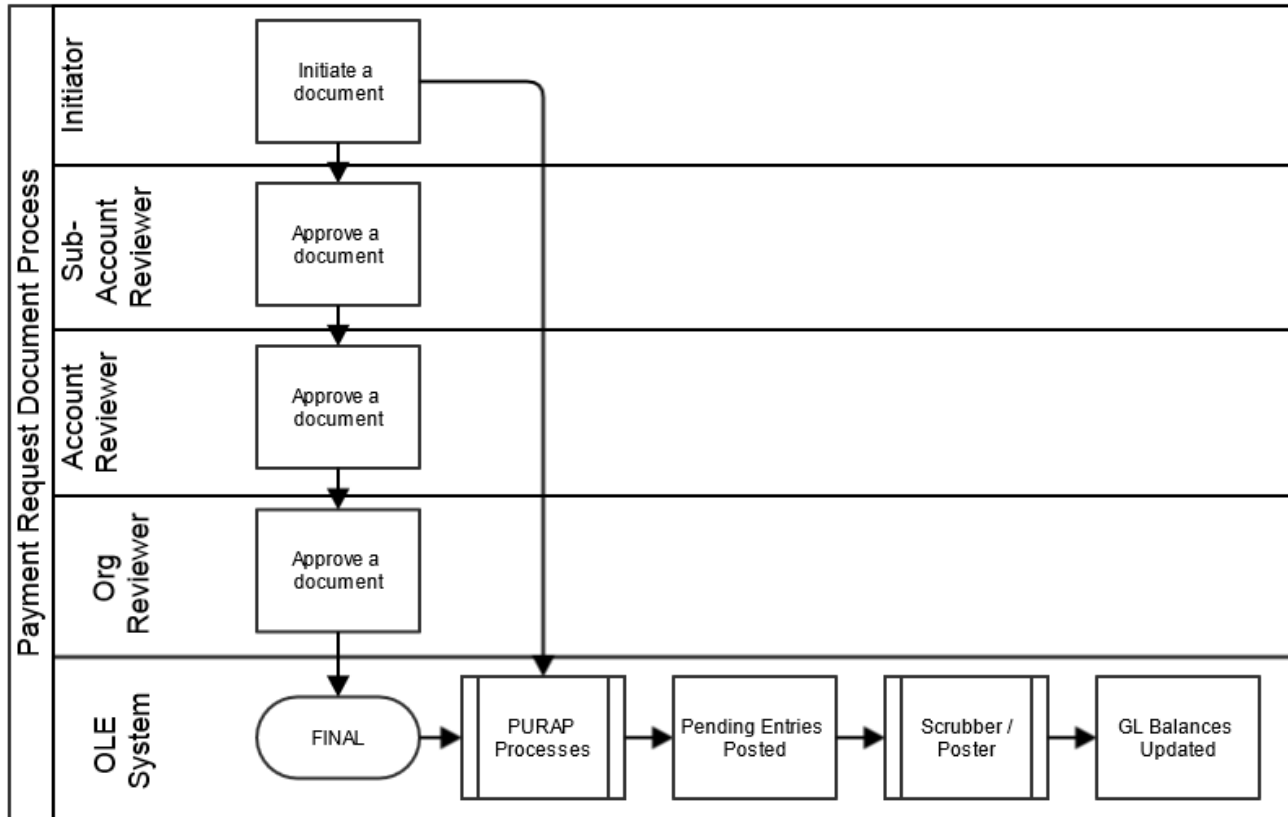

Initiating a Payment Request Document

1. Select **Payment Request** from the **Purchasing/Accounts Payable** submenu group in the **Acquisitions** submenu on the **Main Menu** tab.

The system displays a blank **Payment Request Initiation** tab with a new document ID.

2. Enter the purchase order number, invoice number, invoice date, and vendor invoice amount on the **Payment Request Initiation** tab.

3. Click  .

4. Complete the **Vendor** tab.

- a) Verify that the address on invoice is the same as the one on the Vendor file.
- b) Enter the Acquisition Unit's Vendor Account/ Vendor Info Customer #as needed.
- c) Modify payment terms as needed.
- d) Add check stub notes or special handling instructions if requested.

5. Complete the **Invoice Info** tab.

- a) Select **Immediate Pay** if applicable.

- b) Select **Payment Attachment Indicator**, if applicable.
 - c) Clear the pay date if the payment terms have been modified and the system-calculated pay date is desired.
6. Complete the **Process Items** tab:
- a) In the **Process Titles** section, enter the number of copies and parts.
 - b) In the **Additional Charges** section enter an extended cost amount if needed. Miscellaneous charges require a description.
7. Complete the common tabs as necessary: **Document Overview, Notes and Attachments, Ad Hoc Recipients, and Route Log.**

Note

For more information about the standard tabs, see [Standard Tabs](#) on the *OLE E-Docs fundamentals* wiki page.

Close Purchase Order

An authorized user can opt to **Close PO** at the completion of the Payment Request, via a checkbox by the document total charges:

Invoice Total Prior to Additional Charges:		39.95	
Additional Charges ▶ show			
Grand Total:		39.95	<input type="checkbox"/> Close

Alternatively, Purchase Orders can be closed via action buttons at the bottom of Purchase Order once payments have been completed. Accounts Payable staff has the **Close PO** flag for non-recurring purchase orders available while processing the payment request

- 8. Click **calculate**. (OLE will expect you to calculate an invoice before you **submit** or **save** it.)
- 9. Click **submit**. **Submit** or **approve** the payment request, depending on your OLE permissions and the workflow at your institution. Submitting a payment request uses the OLE internal routing mechanism to route it to the designated approving officer at your institution.
- 10. Appropriate Sub-Account, fiscal officers, and organization reviewers approve the document.

Approving a payment request is only available to authorized users. (In OLE 0.6, you can log in as user ole-abeal to have approval capabilities). An approved payment request will trigger the system to transmit data to another designated system, like a university's accounts-payable system. This will be in future releases.

Note

For more information about how to approve a document, see [Workflow Action Buttons](#) in the *OLE Workflow Overview and Key Concepts* wiki page.

Putting a Payment Request on Hold

An AP user or an approver who receives a payment request for approval may choose to put the payment request on hold or remove a hold from the payment request.

To place a payment request on hold, you must attach a note to the document explaining the reason it has been put on hold. The payment request is then marked as **Hold** = 'Yes'. **Hold** is an indicator; the document's status does not change.

The hold flag prevents a payment request from being extracted and paid. A payment request may be put on hold any time between submit and the time it is extracted to the Pre-Disbursement Processor. When a document is taken off hold, it retains the status it had when the hold flag was turned on.

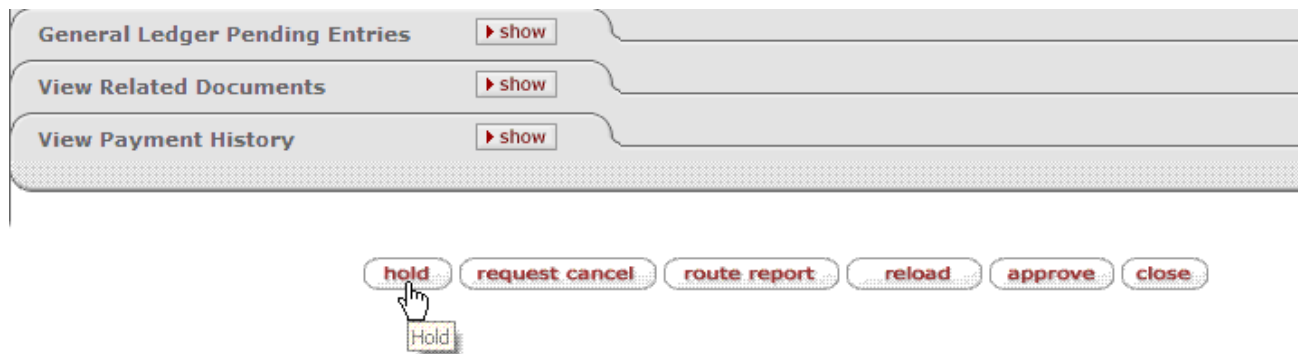

11. Click the  button.

12. In the field displayed, enter a reason for putting the payment on hold.

The image shows a dialog box with a white background and a black border. At the top, it says "Please hold the Payment Request now." Below that, there is a red asterisk followed by the text "* Please enter the reason below:". Underneath is a text input field containing the text "Hold for confirmation of receipt." At the bottom of the dialog box, there are two buttons: "yes" and "no".

13. Click  to put the payment request on hold.

The payment request is marked Hold='yes' and a large header appears at the document indicating who placed the order on hold.

This Payment Request has been Held by RENFROW,ROBERTA G

Document Overview		▼ hide
Document Overview		
* <u>Description:</u>	PO: 1017 Vendor: ABC CLEANING SERVICES	<u>Explanation:</u>
* <u>Year:</u>	2008	
<u>Total Amount:</u>	30.00	<u>Org. Doc. #:</u>

Removing a Hold from the Payment Request

Either the person who placed a payment request on hold or an AP supervisor may take a payment request off hold. This user must provide a reason for taking the payment request off hold.

14. Open the document and click the **remove hold** button.

Route Log	▶ show
General Ledger Pending Entries	▶ show
View Related Documents	▶ show
View Payment History	▶ show
Status History	▶ show

remove hold **route report** **reload** **approve** **close**

15. In the window displayed, provide a reason for taking the payment request off hold.

Please remove the hold on Payment Request now.

* Please enter the reason below:

Goods received. Okay to pay.

yes no

16. Click  to take the payment request off hold.

Cancellation of Payment Request

The Account Payable Processor who receives a payment request may choose to request cancellation of the payment request or may remove the request cancellation of the payment request.

Requesting To Cancel a Payment Request

An approver who receives the payment request may choose to request that it be canceled. After a request cancel has been made, the payment request cannot be routed or paid until the cancel request is removed.

A request cancel may be made any time after the payment request has begun routing for approval and before it has received fiscal officer approval. After a request cancel has been made, the actual cancellation is performed by Accounts Payable.

Tip

After a payment request has received fiscal officer approval, it may still be canceled by Accounts Payable until it is extracted to the Pre-Disbursement Processor.

To request cancellation:

17. Open the document and click the  button.

General Ledger Pending Entries

View Related Documents

View Payment History

Status History

18. In the window displayed, provide a reason for canceling the request.

Please request to cancel the Payment Request now.

* Please enter the reason below:

Duplicate payment made on invoice #123456.

19. Click to cancel the payment request.

The document provides an informational message stating who has requested cancel of the document.

This Payment Request has been Requested for Cancel by RENFROW,ROBERTA G

Document Overview

Document Overview		Explanation:
* Description:	PO: 1030 Vendor: ACCOUNTING CONSULTANTS	
* Year:	2008	
Total Amount:	2,475.00	Org. Doc. #:

Removing a Request to Cancel

Only the AP supervisor or the approver who originally requested cancellation may remove the cancellation request.

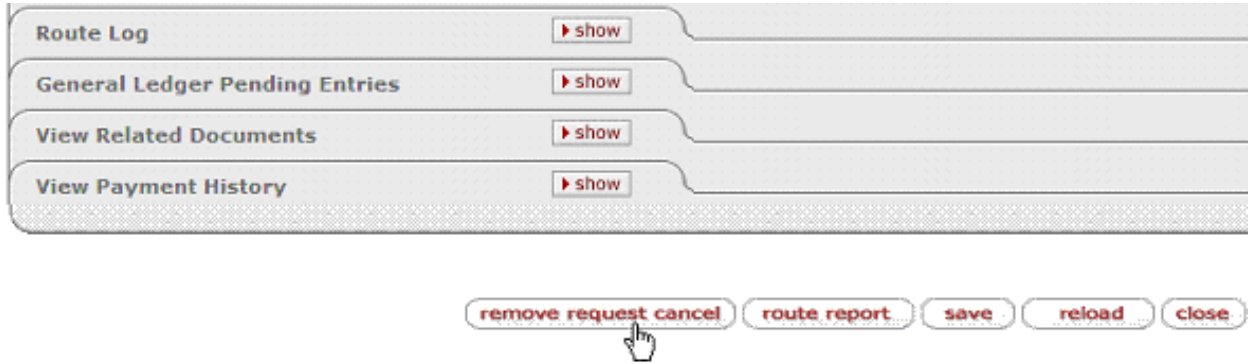

20. Click remove request cancel

Please remove the request to cancel the Payment Request now.

* Please enter the reason below:

Payment should be made. Removing request cancel

yes no

21. Enter the reason for removing the request cancellation request.

When the request cancel is removed, the document retains the status it had before the **request cancel** flag was set.

Automated Approval

Your institution may use an automated approval function for payment request documents. For payment requests that qualify for auto-approval, the system automatically enters 'Processed' status on the pay date. Any user who normally would have received the document for approval instead receives an acknowledgement copy of the document in his or her **action list**.

Tip

Specific accounts may be excluded from auto-approval by adding them to the Auto Approve Exclude administration table. If one account on a PREQ document is excluded from auto-approval, the entire document is excluded.

A payment request is eligible for auto-approval if:

- The total invoice amount is less than the auto-approve threshold designated by your institution.
- All accounts on the Payment Request document allow for auto-approval.
- The payment is not on hold.
- The payment is not on request cancel.

General Error Correction



Cash: In Libraries, we often think of cash/actuals as a summary of available balances, however in OLE/KFS, we have the options to manage both sides of accounting- expenses/liabilities and Cash. While General Ledger and Transfer of Funds functions are noted here, we may/may not use Transfer of Funds or other GL correction documents inherited from KFS in adoptable OLE 1.0. The reason for this is simple (and complex): Libraries don't really operate from 'cash' but from budgets, as the university financial systems manage the actuals/cash and report back to libraries.

In OLE 1.0 and 1.5, we will be reconciling university financial integrations and OLE's use of Budget vs. Actual (cash) balances.

As an option, the General Error Correction (GEC) document is used to correct inappropriate or erroneous accounting string data for General Ledger entries generated from other financial transactions.

By consistently referring to the details of each transaction being corrected, the GEC preserves and maintains the audit trail. Fiscal officers and support staff, department and responsibility center are typical users of the GEC.

Document Layout

The GEC document only has the standard financial transaction document tabs and does not have any unique tabs of its own

Note

For information about the standard tabs such as **Document Overview**, **Notes and Attachments**, **Ad Hoc Recipients**, **Route Log**, and **Accounting Lines** tabs, see [Standard Tabs](#) on the *OLE E-Doc Fundamentals* wiki page.

General Error Correction ?
Doc Nbr: 370

Initiator: ole

Document Overview ▼ hide

Document Overview

* Description: <input style="width: 90%;" type="text"/>	Explanation: <input style="width: 90%;" type="text"/>
Organization Document Number: <input style="width: 90%;" type="text"/>	

Financial Document Detail

Accounting Lines ▼ hide

Accounting Lines ?

From	* Chart	* Account Number	Sub-Account	* Object	Sub-Object	Project	On
	<input style="width: 90%;" type="text"/>	<input style="width: 90%;" type="text"/>	<input style="width: 90%;" type="text"/>	<input style="width: 90%;" type="text"/>	<input style="width: 90%;" type="text"/>	<input style="width: 90%;" type="text"/>	<input style="width: 90%;" type="text"/>
add:	* Reference Origin Code	* Reference Number	Line Description				
	<input style="width: 90%;" type="text"/>	<input style="width: 90%;" type="text"/>	<input style="width: 90%;" type="text"/>				
To	* Chart	* Account Number	Sub-Account	* Object	Sub-Object	Project	On
	<input style="width: 90%;" type="text"/>	<input style="width: 90%;" type="text"/>	<input style="width: 90%;" type="text"/>	<input style="width: 90%;" type="text"/>	<input style="width: 90%;" type="text"/>	<input style="width: 90%;" type="text"/>	<input style="width: 90%;" type="text"/>
add:	* Reference Origin Code	* Reference Number	Line Description				
	<input style="width: 90%;" type="text"/>	<input style="width: 90%;" type="text"/>	<input style="width: 90%;" type="text"/>				

General Ledger Pending Entries ▶ show

Notes and Attachments (0) ▶ show

Ad Hoc Recipients ▶ show

Route Log ▶ show

submit
save
blanket approve
close
cancel
copy

Note

The Year-End General Correction (YEGE) document is available only during the fiscal year-end close.

Process Overview

Business Rules

- Debits must equal credits.
- OLE automatically generates cash offset entries as defined by the information entered into the document.

The following object sub-types are prohibited on this document:

Restricted object sub type in the GEC document

Sub-Type	Description	Restrictions
BU	Budget Only Object Codes	Use Budget Adjustments (BA) document.
CA	Cash	Use Journal Voucher (JV) document.
FB	Fund Balance	Use Journal Voucher (JV) document.

Acquisitions: Standard Transactional Documents

FR	Fringe Benefits	Use Benefits Expense Transfer document.
HW	Hourly Wages	Use Salary Expense Transfer document.
LD	Loss on Disposal of Assets	Use CAMS Documents.
MT	Mandatory Transfers	Use Transfer of Funds (TF) document.
OP	Other Provisions	Use Auxiliary Voucher (AV) document.
SA	Salaries and Wages	Use Salary Expense Transfer document.
TF	Transfer of Funds	Use Transfer of Funds (TF) document.
TN	Transfer - Generic	Use Transfer of Funds (TF) document.
WO	Write-Off Expense	Use Distribution of Income/Expense (DI) document.

Routing

Fiscal Officers for all accounts must approve the GEC document. Additional approvals may be established within the institution's review hierarchy or set up through Ad Hoc routing. The document status becomes 'FINAL' when the required approvals are obtained and the transaction is posted to the G/L during the next G/L batch process.

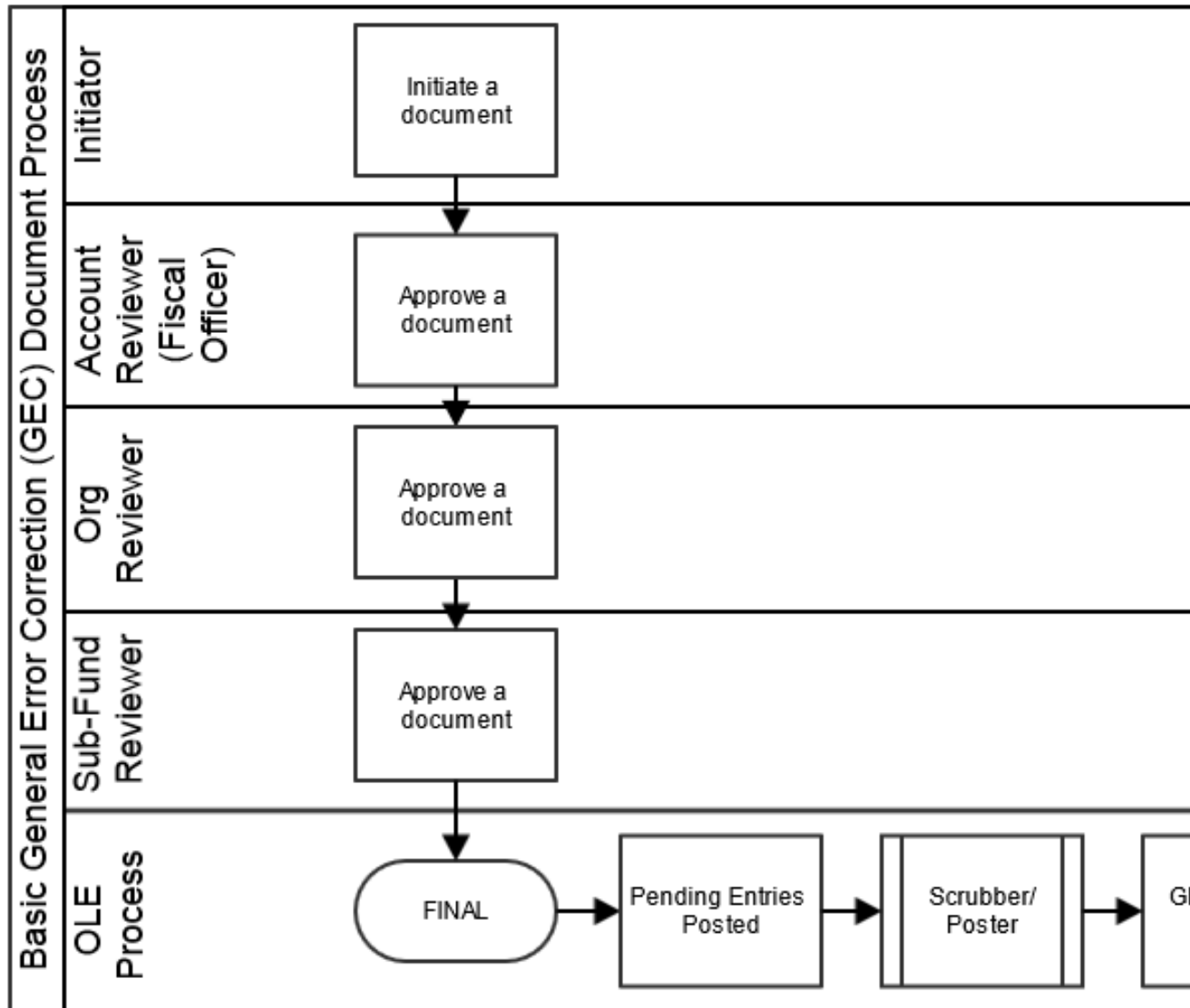

Initiating a GEC Document

22. Select General Error Correction from the **Financial Processing** submenu group in the **Transactions** submenu on the **Main Menu** tab.

A blank GEC document with a new document ID appears.

23. Complete the standard tabs.

- The **Accounting Lines** tab of the GEC document varies slightly from other types of financial transaction documents:
- The **Ref Number** is a required field on the GEC document. This field identifies the reference number of the document being corrected.
- The **Line Desc** box is optional and can be used to enter a description specific to that line of the GEC. If left blank, the description from the **Document Overview** tab passes to the G/L for that line of the transaction.
- The **Ref Origin Code** is a required field. This code identifies the system that created the transaction being corrected.

Note

For information about the standard tabs such as **Document Overview**, **Notes and Attachments**, **Ad Hoc Recipients**, **Route Log**, and **Accounting Lines**, see [Standard Tabs](#) on the *OLE E-Doc Fundamentals* wiki page.

24.

Click .

25. Review the **General Ledger Pending Entries** tab.

This document automatically generates cash offset entries to cash or fund balance object codes.

26. Review the **Route Log** tab.

The document is routed to the fiscal officer for each account used in the Accounting Lines. The Route Status shows 'ENROUTE'.

Note

For information about the Route Log tab, see [Route Log](#) on the *OLE Workflow Overview and Key Concepts* wiki page.

27. Appropriate fiscal officers and organization reviewers approve the document.

Note

For more information about how to approve a document, see [Workflow Action Buttons](#) on the *OLE Workflow Overview and Key Concepts* wiki page.

Example

Supplies were charged to an incorrect account. Use the **From** section to move the expense (credit expense) from the incorrect account and the **To** section to charge expense to the correct account (debit expense).

Acquisitions: Standard
Transactional Documents

The correct expense is debited and the incorrect expense is credited. The GEC document allows users to easily make corrections to documents previously submitted and approved.

General Error Correction Doc Nbr: 3
Initiator: k

Document was successfully saved.

Document Overview hide

Document Overview

* Description: correct expense account Explanation: correct department coding on disbursement

Org. Doc. #:

Financial Document Detail Total Amount: 550.00

Accounting Lines hide

Accounting Lines ?

From

	* Chart	* Account Number	Sub-Account	* Object	Sub-Object	Project	Org Ref
add:	<input type="text"/>	<input type="text"/>	<input type="text"/>	<input type="text"/>	<input type="text"/>	<input type="text"/>	<input type="text"/>
	* Reference Origin Code	* Reference Number	Line Description				
	<input type="text"/>	<input type="text"/>	<input type="text"/>				
1	BL BLOOMINGTON	1031420 CENTER FOR ANIMAL BEHAVIOR	<input type="text"/>	5000 SUPPLIES AND EXPENSE	<input type="text"/>	<input type="text"/>	<input type="text"/>
	* Reference Origin Code	* Reference Number	Line Description				
	CS	FMS5896548	<input type="text"/>				

To

	* Chart	* Account Number	Sub-Account	* Object	Sub-Object	Project	Org Ref
add:	<input type="text"/>	<input type="text"/>	<input type="text"/>	<input type="text"/>	<input type="text"/>	<input type="text"/>	<input type="text"/>
	* Reference Origin Code	* Reference Number	Line Description				
	<input type="text"/>	<input type="text"/>	<input type="text"/>				
1	BL BLOOMINGTON	2231404 * Account Expired Override <input checked="" type="checkbox"/> XXXXX-RIP-PSYCHOLOGY	<input type="text"/>	5000 SUPPLIES AND EXPENSE	<input type="text"/>	<input type="text"/>	<input type="text"/>
	* Reference Origin Code	* Reference Number	Line Description				
	CS	FMS5896548	<input type="text"/>				

Capital Edit show

General Ledger Pending Entries hide

General Ledger Pending Entries ?

Seq #	Fiscal Year	Chart	Account Number	Sub-Account	Object	Sub-Object	Project	Doc Type	Balance Type
1	2010	BL	1031420	----	5000	---	-----	GEC	AC
2	2010	BL	1031420	----	8000	---	-----	GEC	AC
3	2010	BL	2231404	----	5000	---	-----	GEC	AC
4	2010	BL	2231404	----	8000	---	-----	GEC	AC

Notes and Attachments (0) show

Ad Hoc Recipients show

Route Log show

Disbursement Voucher

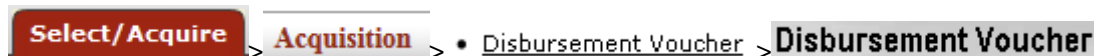

Note

In order for users to submit the Disbursement Voucher document, the `ENABLE_BANK_SPECIFICATION_IND` parameter must be set to Y and the `DEFAULT_BANK_BY_DOCUMENT_TYPE` parameter must be completed. Even if your institution is not planning to use the Bank Offset feature in OLE, the `DEFAULT_BANK_BY_DOCUMENT_TYPE` parameter must be completed if your users plan to use the Disbursement Voucher document. Bank offsets will not be created if the Bank Offset feature has not been configured.

The Disbursement Voucher (DV) document can be used to issue payments to vendors using clearing/deposit accounts. The DV can be used for recording the Advance Deposits or Prepayments to vendors, when titles or POs are unknown.

The disbursement voucher may be used in situations in which a payment is not processed through another procurement method, such as purchase order or procurement card.

A disbursement voucher requires more information than most financial documents. Each disbursement voucher must include the following information:

- Who is to be paid (the 'Payee')
- Why the payee is being paid (the 'Payment Reason')
- How much the payee is to be paid and how the payment is to be made (the 'Amount' and 'Payment Method')
- Where any supporting documentation is stored (the 'Documentation Location')
- Whether any forms or documents need to be physically sent with the payment (the 'Check Enclosure')
- All information on the **Contact** tab.

Users must also keep the following points in mind about DVs:

- Some payment reasons may require that additional information be entered.

Note

Disbursement Vouchers have been modified from the original KFS and continue to be reviewed for OLE use.

Document Layout

The DV document has several unique tabs—**Payment Information**, **Contact Information**, **Special Handling**, **Foreign Draft**, and **Pre-Disbursement Processor Status**—in addition to the standard financial transaction tabs.

Note

For more information about the standard tabs, see [Standard Tabs](#) on the *OLE E-Doc Fundamentals* wiki page.

Acquisitions: Standard
Transactional Documents

Disbursement Voucher ?	Doc Nbr: 4175	Stat
	Initiator: ole-khuntley	Creat

Document Overview ▼ hide

Document Overview

* Description:	<input type="text"/>	Explanation:	<input type="text"/>
Organization Document Number:	<input type="text"/>		

Financial Document Detail

* Bank Code	TEST FIRST NATIONAL TEST BANK OF KUALI
-------------	-------------------------------------------

Payment Information ▼ hide

Payment Information

* Payment Reason Code:	<input type="text"/>	* Payee Name:	<input type="text"/>
* Payee ID:	<input type="text"/>	* Payee Type:	<input type="text"/>
* Address 1:	<input type="text"/>	* Address 2:	<input type="text"/>
* City:	<input type="text"/>	* State:	<input type="text"/>
* Country:	<input type="text"/>	* Postal Code:	<input type="text"/>
* Check Amount:	0.00	* Due Date:	02/21/2013
Payment Type: <input type="checkbox"/> Is this a foreign payee <input type="checkbox"/> Is this for Deposit Account Is this payee an employee:	Other Considerations: <input type="checkbox"/> Check Enclosure <input type="checkbox"/> Special Handling <input type="checkbox"/> W-9/W-8BEN Completed <input type="checkbox"/> Exception Attached		
* Payment Method:	<input type="text"/>	* Documentation Location Code:	F - FMS - Bloomington
* Check Stub Text:	<input type="text"/>		

Accounting Lines ▼ hide

Accounting Lines ?

Source	* Chart	* Account Number	Sub-Account	* Object	Sub-Object	Project	Org Ref Id	* Dollar \$	* Perc
add:	<input type="text"/>	<input type="text"/>	<input type="text"/>	<input type="text"/>	<input type="text"/>	<input type="text"/>	<input type="text"/>	0.00	<input type="text"/>

Contact Information ▼ hide

Contact Information

* Contact Name:	HUNTLEY, KEISHA Y
* Phone Number:	<input type="text"/>
Email Address:	test@email.edu
Campus Code:	BL - BLOOMINGTON

Special Handling ▶ show

Foreign Draft ▶ show

Pre-Disbursement Processor Status ▶ show

General Ledger Pending Entries ▶ show

Notes and Attachments (0) ▶ show

Ad Hoc Recipients ▶ show

Route Log ▶ show

submit save close cancel copy

In addition to the **Document Overview** and **Accounting Lines** tabs, two DV-specific tabs, **Payment Information** and **Contact Information**, are always required.





- The **Payment Information** tab contains information regarding the payee, payment reason, payment method, documentation location, and attachments.
- The **Contact Information** tab contains information relating to the initiator and contains the text to be included on the check stub.

Other tabs may be required based on the selections made in the **Payment Information** tab.



Payment Information Tab

The **Payment Information** tab contains important information such as the payment reason, amount, payment method, attachments, and documentation location. This section must be completed for every DV document.

Payment Information tab definition

Title	Description
Payment Reason Code	Required. Display-only. This code identifies the reason for the disbursement and determines any restrictions the payment is subject to. After you select the payee ID from the Payee lookup  , the system automatically fills in the payment code reason.
Payee ID	Required. Retrieve the payee ID from the Payee Lookup  .
Payee Type	Display-only. After you select the payee ID from the Payee lookup  , the system automatically fills in the type of payee.
Name	Display-only. After you select the payee ID from the Payee lookup  , the system automatically fills in the name.
Address 1	Required. The first line of address to which the check should be mailed. The system fills in this information automatically but you may change it.
Address 2	Optional. Enter the second line of the address to which the check should be mailed.
City	Required. Enter the city to which the check should be mailed.

Acquisitions: Standard
Transactional Documents

State	Required for US. Enter the state to which the check should be mailed.
Country	Optional. Select the payee's country from the Country list.
Postal Code	Required for US. Enter the postal code to which the check should be mailed.
Check Amount	Required. Enter the total amount of the disbursement for this document.
Due Date	Required. Enter the date or select it from the calendar  . The default date is the earliest date that a payment can be made (assuming OLE is processing batch transactions nightly, this is typically the next business day). If you wish the payment to be made as soon as possible, do not change the default date. If you wish to delay a payment until a future date you can set the due date forward. Payment information is not extracted from OLE until the due date.
Payment Type	Optional. Display-only. The payment types are determined by the payee selected for the DV. These values apply only to DV payees, which are established through the use of the Payee Type document. Each Payment Type attribute from the Payee Type record that is evaluated when the DV is submitted may have an impact on the ability to process a particular payment on a DV, and how it routes for approval. Is this a foreign payee? If the payee is a nonresident alien, select 'Yes'. Employee Paid Outside of Payroll? If the Payee record is an Employee record or a Vendor record with the same tax identification number as an Employee record, then this is set to 'Yes'. Your institution may wish to perform specialized review on these transactions to make sure they should not be processed through your regular payroll process.
Other Consideration	Optional. Select these check boxes as necessary to reflect special circumstances or special requests that are needed for the payment: Check Enclosure: Refers to any documents related to the DV document that must accompany the check when it is mailed to the payee. Selecting the check box properly indicates that there is a form or other attachment that must accompany the check. Special Handling: Indicates that the payment should be mailed to a person other than the payee. For example, a check needs to be returned to the document initiator so it can be express mailed or picked up by the payee. When selected, a message asking you to add a note explaining the need for special handling is displayed. W9/W-8BEN Completed: Indicates if the payee has a W-9 (or W-8BEN for nonresident aliens) on file. For nonemployees this is generally completed as part of processing of the Payee document. Exception Attached: Indicates that you are requesting an exception to policy on this DV document. For instance, your institution may require that all disbursement vouchers have supporting documentation, but in this case you do not have such documentation. When this option is selected, a message prompting you to add a note of explanation is displayed.
Payment Method	Required. Select the method in which the payment should be made from the Payment Method list. Foreign Draft: This selection indicates that the payment is to be made in a foreign currency. When you select Foreign Draft as the payment method you are prompted to complete the Foreign Draft tab. In this section, you indicate whether the DV is stated in foreign currency or US dollars, and what currency the payment is to be made in. For example, the DV could be stated in Euros and paid in Euros, or the DV could be stated in US Dollars converted to Euros for payment. Wire Transfer: This selection indicates you wish to have the disbursement wired to the recipient. To do so you are required to provide additional banking information on the Wire Transfer tab. Some institutions may charge a fee to the initiating department for processing a wire transfer. Wire transfers may be made in US Dollars or foreign currency, similar to Foreign Drafts as described above.
Documentation Location Code	Required. Select the unique code for the location where the documentation is to be kept from the Documentation Location Code list or lookup  .

Acquisitions: Standard
Transactional Documents

	<p>This indicates where supporting documentation should be sent, as well as who is responsible for maintaining the documentation. Supporting documentation refers to documents or backup submitted with the disbursement voucher (receipts, invoices, letters, memos) that detail what was purchased, the cost, the name of the vendor and the date of the transaction.</p> <p>Initiating Organization: Indicates that your department plans to retain the documentation. When you select this location you may receive a message with additional instructions based on your institution's procedures and documentation retention policies.</p> <p>No Documentation: Indicates that you have no supporting documentation for this transaction. If selected, you are required to attach a note in the Notes and Attachments tab of the document explaining why.</p>
Check Stub Text	Required. Enter the information regarding the payment itself, intended for the payee. This commonly includes what the payment is for (invoice number, for example) or other information to assist the payee in identifying the source and reason for the payment.

Note

For more information about the Payment Reason Code, see [Payment Reasons](#).

Note

Notes regarding Documentation Location: Restrictions may be in place, which require you to send your documentation to a particular location. Your institution may have other specific requirements based on Payment Reason or other attributes of the transaction. Specific locations can be customized and may vary from institution to institution.

The payee ID is required on the **Payment Information** tab. This identifies the person or business the disbursement is paid to. Payees must exist in the system in order to be selected on the disbursement voucher. OLE uses the Vendor table and the Customer Profiles setup in Pre-Disbursement Processor module for reference. If the payee already exists in the system, you can identify it by searching for it by using the **Payee** lookup.



Several OLE parameters exist to control which types of payees can be selected for a given payment reason. After clicking **search**, the restrictions for the selected payment reason are displayed at the top of the lookup.

Payee Lookup

Click the magnifying glass  next to **Payee ID**.

Payee Lookup 

- Vendor is the only valid Payee Type for Payment Reason W - Subscriptions,Books,FEES,Resale.



* Payment Reason Code:	W - Subscriptions,Books,FEES,Resale
Vendor Tax Number:	<input type="text"/>
Payee Name:	<input type="text"/> 
Vendor Name:	<input type="text"/> 
Employee ID:	<input type="text"/>
Vendor #:	1000-0
Active?:	<input checked="" type="radio"/> Yes <input type="radio"/> No <input type="radio"/> Both
<input type="button" value="search"/> <input type="button" value="clear"/> <input type="button" value="cancel"/>	

One item retrieved.

Return Value	Payee Name	Payee Type	Address	Payee Number	Active?	Vendor T
return value	ALEPH-BET BOOKS	Vendor	123456 BROAD ST, TRUMANSBURG, NY US	1000-0	Yes	112233445

Export options: [CSV](#) | [spreadsheet](#) | [XML](#)

Payee Lookup search criteria

Title	Description
Payment Reason Code	Required. Select a payment reason from the list.
Vendor Tax Number	Optional. Enter the Tax Number associated with the payee.
Payee Name	Optional. Enter the name of the payee as established in OLE or search for it from the lookup 
Vendor Name	Optional. Enter the name of the vendor as it appears in the Vendor table or search for it from the lookup 
Employee ID	Optional. Enter the unique ID assigned to Employees in the Person table. The value may come from your HR system.
Vendor #	Optional. Enter the Vendor Number as it appears in the Vendor table.
Active ?	Optional. Select the Yes , No , or Both options. You may search for payees with any status, but payments cannot be made to inactive payees.

Tip

Because OLE continues to develop Deposit Account functionality and some of the KFS data still exists within the system, using the Payee Lookup can be confusing. Select a **Payment Reason Code**, enter a library-associated **Vendor #**, and click search.

Note

For information about lookup, see [Field Lookup](#) on the *OLE E-Doc Fundamentals* wiki page.

Contact Information Tab

The **Contact Information** tab contains information that is intended to be printed on the check. When the DV document is first initiated, the **Contact Name** and the **Campus Code** default to those of the initiator's.

The Contact for a DV is typically the initiator, thus the contact information is typically the name, phone, and email address of the initiator.

Contact Information tab definition

Title	Description
Contact Name	Required. This field is pre-filled with the name of the document initiator but may be edited.
Phone	Required. Enter the contact person's phone number (including area code)
Email Address	Required. Enter the contact person's email address
Campus Code	Display-only. The code of the campus associated with the document's initiator, derived from the user's profile.

Note

The information in this tab is included on the check stub and is seen by the payee when they receive the check. If you want to include information that only other OLE users can view, add a note or attachment to the document instead. For more information about the **Notes and Attachments** tab, see [Notes and Attachments Tab](#) on the *OLE E-Doc Fundamentals* wiki page.

Special Handling Tab

The **Special Handling** tab is used only when a check is to be sent to someone other than the payee. If the payee has requested the payment be mailed to them, but at a different address, simply change the address in the **Payee** tab. To request Special Handling for the payment, select the **Special Handling** check box in the **Payment Information** tab and complete the fields on this tab.

Special Handling tab definition

Title	Description
-------	-------------

Acquisitions: Standard
Transactional Documents

Special Handling Name	Required. Enter the name of the person or entity where the check should be mailed.
Special Handling Address 1	Required. Enter the first line of address where the check should be mailed.
Special Handling Address 2	Optional. Enter the second line of address where the check should be mailed.
Special Handling City	Optional. Enter the city where the check should be mailed.
Special Handling State	Optional. Enter the state where the check should be mailed.
Special Handling Postal Code	Optional. Enter the postal code where the check should be mailed.
Special Handling Country	Optional. Select the payee's country from the Country list.

Foreign Draft Tab

When you select **Foreign Draft** as the payment method you are prompted to complete the **Foreign Draft** tab as seen below:

Foreign Draft tab definition

Title	Description
DV amount is stated in U.S. dollars; convert to foreign currency	Optional. Select this option if the DV amount is stated in U.S. Dollars and needs to be converted to a foreign currency.
DV amount is stated in foreign currency	Optional. Select this option if the DV amount is stated in a foreign currency.
Currency Type	Required. Enter the type of currency for the payment.

Pre-Disbursement Processor Status Tab

The **Pre-Disbursement Processor Status** tab displays information from the Pre-Disbursement Processor (PDP) so you can track the payment status and the status date.

Disbursement Voucher Pre-Disbursement Processor Status	
Pre-Disbursement Processor Status:	Canceled
PDP Extraction Date:	12/06/2007
PDP Paid Date:	
PDP Cancellation Date:	12/06/2007

Pre-Disbursement Processor Status tab definition

Title	Description
Pre-Disbursement Processor Status	Display-only. Displays the payment processing status from the Pre-Disbursement Processor (PDP).
PDP Extract Date	Display-only. The date when the disbursement voucher was extracted for payment processing by the PDP.
PDP Paid Date	Display-only. The date when the payment was disbursed by PDP.
PDP Cancellation Date	Display-only. The date when the payment was canceled within PDP.

Print Disbursement Voucher Cover Sheet Link

If you have attachments or supporting documentation that needs to go to another university location you can print a cover sheet to accompany them. This cover sheet contains identifying information about the DV as well as an address field indicating where these materials should be sent.

To print a cover sheet, click the **Print Disbursement Voucher Cover Sheet** link

[Print Disbursement Voucher Coversheet](#)  which becomes available in the upper middle area of the document after you successfully submit the document.

Disbursement Voucher 	Doc Nbr:	173411
	Initiator:	ICHANC

Document was successfully submitted.

[Print Disbursement Voucher Coversheet](#) 

Document Overview ▼ hide

* Description:	* Explanation:
Test DV	
	Org. Doc. #:

The cover sheet opens as a PDF document. Print the document, send it along with any attachments or supporting documentation and send it to the address shown on the cover sheet.

WFTOM
P - Check/ACH

Check Total: 100.00

Jerry Neal
170929

Compensation for Services

DISBURSEMENT VOUCHER COVER SHEET

PLEASE ATTACH SUPPORTING DOCUMENTATION AND/ OR THE
ATTACHMENT(S) ASSOCIATED WITH THIS DOCUMENT NUMBER

Financial Management Support
Poplars 526
BLOOMINGTON CAMPUS

Process Overview

Business Rules

- DV Payee cannot be the same as the initiator.
- DV Payee must be active.
- Check amount cannot be negative.
- There must be at least one accounting line.
- Account lines total must not be negative. Total of accounting lines must match the **Check Total** field.
- DVs with Account-Funds designated as Clearing/Deposit or other Payment method to denote deposit, must be routed for approval- no automatic approvals.
- Only a Disbursement Voucher, Credit Memo, Distribution of Income & Expense, or General Error Correction may use Accounts of “Fund Group, Sub-Fund Group” – Clearing or Deposit. These forms of accounts will be restricted for use with prepayments. REQ, PO (versions), PREQ are prohibited from using this Account Type.
- The object codes associated with the following object types or object levels are prohibited:

Object type restrictions for DV documents

Object Type	Description	Restrictions
CH	Cash Not Income	Unallowable
ES	Expense Not Expenditure	Unallowable
FB	Fund Balance	Unallowable
IC	Income Not Cash	Unallowable

Object Level Restrictions for DV Documents

Object Level	Description	Restrictions
BASE	Assessments Expenditures	Unallowable
BASR	Assessments Revenue	Unallowable
BASS	Budget Assets	Unallowable
BCAS	Beginning Cash	Unallowable
BCOM	Budget Compensation	Unallowable
BFRE	Budget-Fee Remission	Unallowable
BGEX	Budget-General Expense	Unallowable
BLIA	Budget-Liability	Unallowable
BORE	Budget-Other Revenue	Unallowable
CRIN	Cost Recoveries-Income	Unallowable
FUBL	Fund Balance	Unallowable
HRCO	Hourly Compensation	Unallowable
ICOR	Indirect Cost Recovery Income	Unallowable

Object Sub Type Restrictions for DV Documents

Object Sub Type	Description	Restrictions
BU	Budget Only Object Codes	Unallowable

Institutions may create their own restrictions for object codes and payee type based on payment reasons.

Payment Reasons

When processing a DV document, users must indicate a payment reason by selecting a **Payment Reason Code** from the **Payment Reason** list in the **Payment Information** tab. The payment reason identifies the nature of the disbursement and determines what restrictions the disbursement is subject to.

Choosing a payment reason may restrict the other choices you can make on the document. For example, most payment reasons only allow certain object codes and some restrict whether the person being paid can be an employee or nonemployee.

The current payment reasons for using a disbursement voucher are explained below as typical examples:

Payment Reason Code

Code	Title	Description
E	Compensation for Services	Used to make payments for services such as artist fees and honoraria payments.
L	Payments for Contractual Agreements	Used to make payments required under a contractual agreement.
F	Refund/Repayment to Individual or Agency	Used to make payment for returned goods sold, or refunds for services rendered. This reason can also include repayment to agencies for contract and grant funding. It is possible to debit an income object code with this payment reason.
B	Reimbursement for Out of Pocket Expense	Used to reimburse individuals for out-of-pocket expenses on behalf of the departmental business operations due to an emergency or a situation where the regular procurement procedures cannot be followed
K	Revolving Fund Reimbursement	Revolving funds are a kind of cash account from which funds can be borrowed when cash on hand is needed for disbursements. Revolving funds are established as special types of payees that can be repaid using a DV document.
W	Subscriptions, Books, Fees, and Resale	Used for any payment covering a renewal or subscription to a newspaper, magazine or to cover membership fees to a professional organization. This reason is also used by some departments, such as bookstores, to purchase books intended to be resold.
G	Utilities, Freight, or Postage	Can be used to pay utility bills, postage, or shipping and freight costs.

Routing

The DV document must route through a series of approvals before the disbursement is actually made based on the rules set up by the institution. Due to its unique nature, the DV document has some special routing issues which are explained below:

- The DV document first routes to the fiscal officer for each account in the **Accounting Lines** tab.
- After it has been approved by all required fiscal officers, the document routes, as specified by the institution's rule, to the organization review routing level.
- After the document has been approved by all organizational approvers, the DV document goes through any special routing as required by business rules surrounding the attributes of the transaction and the payee.

The document status becomes 'FINAL' when the required approvals are obtained and the transaction is processed by the institution defined process, which might include the Pre-Disbursement Processor.

Note

Pre-Disbursement Processing is still under review for OLE and not available for 1.0.

DV special condition routing

Condition	Special Routing
Payee is an employee paid outside of payroll (Payee tab)	OLE-SYS Tax Manager role
Payee requires backup withholding (determined by the presence of backup withholding dates on the Vendor record)	OLE-SYS Tax Manager role
Initiator's Campus	Final approval by members of OLE-FP Disbursement Manager role for the appropriate campus. Campus is based on the campus associated with the initiator's OLE-SYS User role
Payment Method (Payment Information tab) is Wire Transfer	OLE-FP Disbursement Method Reviewer role members associated with Payment Method 'W'.
Payment Method is Foreign Draft	OLE-FP Disbursement Method Reviewer role members associated with Payment Method 'F'.

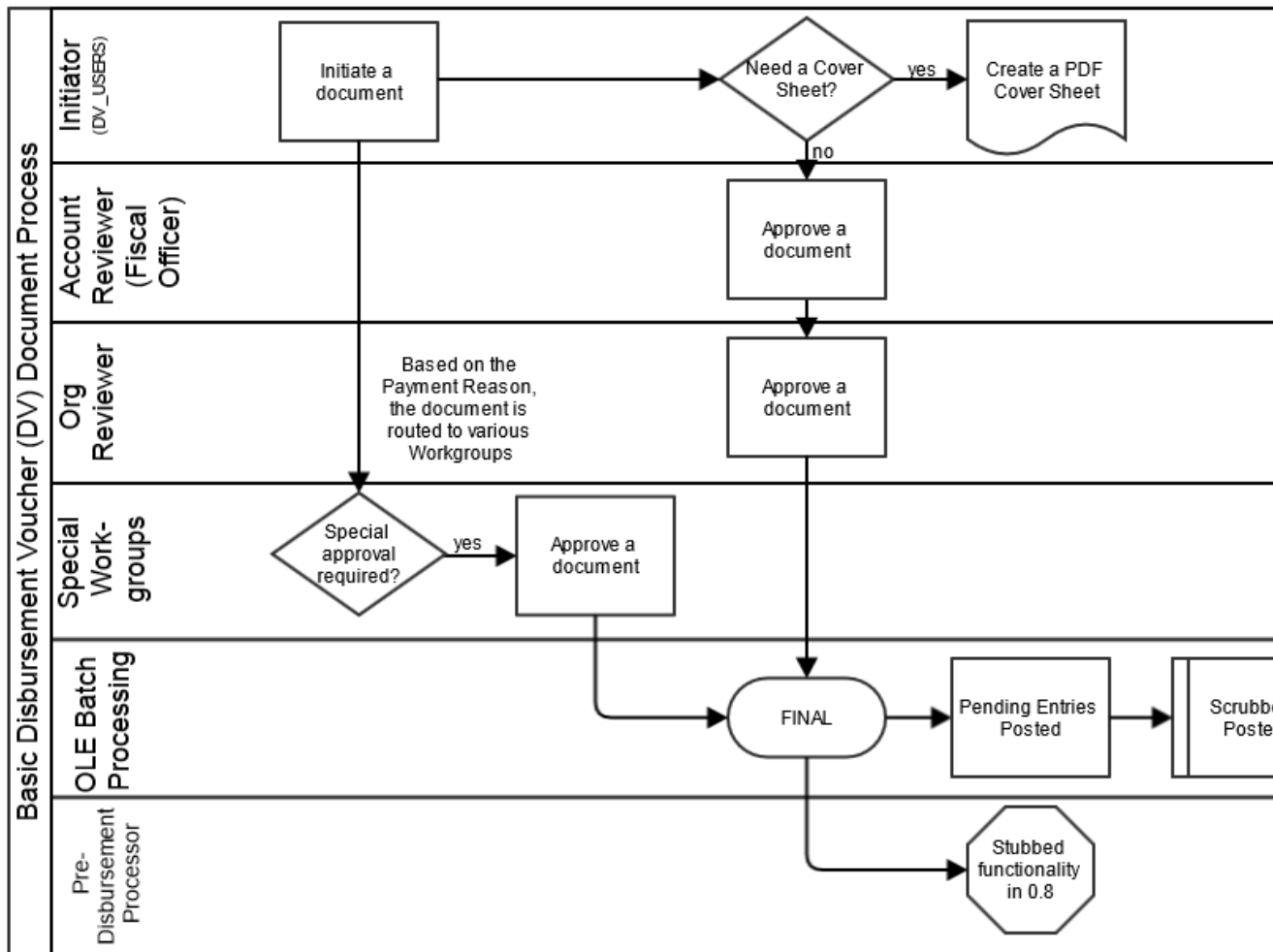

Initiating a DV Document

28. Select **Disbursement Voucher** from the **Financial Transactions** submenu.

29. Log into OLE as necessary.

A blank Disbursement Voucher document with a new document ID appears.

30. Complete the **Payment Information** tab.

If you wish to permanently change a nonemployee's address information, process a Vendor document to change the default address stored in OLE.

Note

For information about the Vendor document, see Vendor (PVEN) in the *Guide to Vendors*. This and other OLE user guides are available for download from the [OLE Documentation Portal](#)

31. Complete the **Payment Information** tab.

32. Complete the **Accounting Lines** tab.

Indicate what accounts and object codes are to be debited when making this disbursement.

33. Complete the **Contact Information** tab, and remaining DV-specific tabs as required.

34. Click .

35. Print a cover sheet, if necessary.

36. Appropriate fiscal officers and organization reviewers approve the document.

Note

For more information about how to approve a document, see [Workflow Action Buttons](#) on the *OLE Workflow Overview and Key Concepts* wiki page.

E-Resource

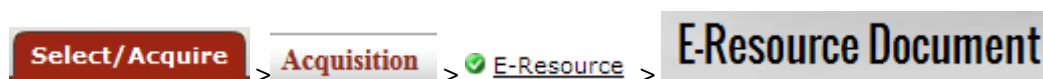

While OLE has adopted functionality from the Kuali Financial System for acquiring print materials that includes placing orders, receiving orders, claiming orders, and paying for orders, acquiring electronic materials and tracking their lifecycle has required additional interfaces and electronic documents.

In 1.0, initial development includes the E-Resource Record and its associated maintenance documents. The E-Resource Record provides a place to store and view information about an electronic resource acquisition, including the title(s) involved and the content provider. Within the OLE user interface, the E-Resource Record presents a single, unified view of all information related to acquisition of an individual electronic resource or group of electronic resources, including titles, payment, licensing, administrative, and contact information.

E-resource acquisition requires the collection and storage of lifecycle management data that is not part of the requisition or purchase order and lacks a home in most current systems. Long-term management of e-resources also requires the ability to view or link to related data from one coherent “place.” There is no eDoc that currently meets these needs. Therefore, we are defining a new type of record to handle e-resources.

Future releases will include a platform record to support electronic resource administration, full GOKb integration, alerts and ticklers to help track and move through the workflow, as well as clear linking to other modules within OLE to request purchase orders and maintain metadata with the E-Instance record.

Note

Electronic acquisitions and the E-Resource Record will continue to be developed and modified in future releases.

Document Layout

Because of the quantity of metadata that the E-Resource holds, the record contains a left-pane navigation bar.

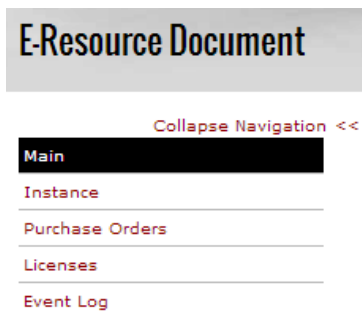

The navigation bar includes:

Table 7.1. E-Resource Navigation Descriptions

Tab Name	Description
Main	Displays the primary data elements and includes tabs for acquisitions, selection and access.
Instance	Users can manage the relationship between the E-Resource Record and OLE Instances and/or OLE E-Instances. In future releases, users will be able to import and manage data from GOKb
Purchase Order	Displays the purchase order number link. Also included at the top of the purchase order list is the sum of all payments for all purchase order line items linked to that E-Resource per fiscal year.
License	Displays license information from the licenses an E-Resource Record is linked to. Users may also start a new License Request from this tab.
Event Log	Contains correspondence between libraries and publishers, vendors, etc. as well as notes about external activities.

Tip

Click **save** when you have completed your work in one tab before moving on to the next. Prepopulated fields will be filled and you will not risk losing anything.

Main M

▼ Acquisitions

* Material Type		Actions
<input type="text"/>	<input type="button" value="add"/>	
* Format		Actions
<input type="text"/>	<input type="button" value="add"/>	
* Content Type		Actions
<input type="text"/>	<input type="button" value="add"/>	
Payment Type: Free <input type="button" value="v"/>	Order Type: Firm, Fixed <input type="button" value="v"/>	Package Type: Consortial <input type="button" value="v"/>
Package Scope: Front File <input type="button" value="v"/>	Breakable: <input type="checkbox"/>	Fixed Title List: <input type="checkbox"/>
Estimated Price: <input type="text"/>	Description: <input type="text"/>	

▼ Selection

Requestor		Actions
<input type="text"/>	<input type="button" value="add"/>	
Selector		Actions
<input type="text"/>	<input type="button" value="add"/>	
Requestor/Selector Comment		Actions
<input type="text"/>		<input type="button" value="add"/>
Priority: 1 <input type="button" value="v"/>		

▼ Access

Type of Access: site-wide <input type="button" value="v"/>	Authentication Type: IP range <input type="button" value="v"/>	No. of Simultaneous User: <input type="text"/>
Access Location: Main Campus <input type="button" value="v"/> Low Campus <input type="button" value="v"/> High Campus <input type="button" value="v"/>	Statistical Code: <input type="text"/>	
Technical Requirements:	<input type="text"/>	

▼ Note

Note	Actions
<input type="text"/>	<input type="button" value="add"/>
Public Display Note:	<input type="text"/>

▶ Ad Hoc Recipients

▶ Route Log

The E-Resource Record Main menu includes the **Overview**, **Acquisitions**, **Selection**, and **Access** tabs, in addition to the standard tabs.

Note

For information about the **standard tabs**, see [Standard Tabs](#) on the *OLE E-Doc Fundamentals* wiki page.

Overview Tab

The E-Resource Record Main menu contains a custom tab called the **Overview** that contains basic information about the E-Resource. The name of the E-Resource, Publisher, Platform and Vendor information as well as identifying information are noted here.

▼ Overview		
		* Name: <input type="text" value="test"/>
Publisher:	<input type="text"/>	OLE Identifier: <input type="text"/>
Platform Provider:	<input type="text"/>	ISBN/ISSNs: <input type="text"/>
Vendor Name:	<input type="text"/> ▼	GOKb Identifier: <input type="text"/>
		* Status: <input type="text"/>
		Status Date: 2

Overview Tab Definitions

Title	Description
Name	Required. The name of the resource. Used also for searching.
Publisher	Record the name of the publisher of the E-Resource.
Platform Provider	The platform provider for the E-Resource. In a future release, this will be linked from the Platform record.
Vendor	The name of the vendor. In a future release, this will be linked to the Purchase Order.
OLE Identifier	Display only. Identifies the E-Resource within OLE.
ISBN/ISSNs	Display only. If the E-Resource Record has only one title, the subfield \$a of the first ISBN/ISSN number from the record will display here.
GOKb Identifier	Display only. In a future release, this field will display the link to the GOKb interface.
Status	Current status of the E-Resource Record.
Status Date	Display only. Date at which the status was set.

Workflow Status Tab

The **Workflow Status** tab will be used in a future release to display the statuses of a trial, license request, purchase, or access/activation.

▼ Workflow Status		
WorkFlow Name	Needed?	Status
Trial:	<input type="checkbox"/>	
License:	<input type="checkbox"/>	

Acquisitions

The **Acquisitions** tab is used to document information about the item(s) purchased and some of the purchasing information.

▼ Acquisitions			
* Material Type		Actions	
<input type="text"/>		<input type="button" value="add"/>	
* Format		Actions	
<input type="text"/>		<input type="button" value="add"/>	
* Content Type		Actions	
<input type="text"/>		<input type="button" value="add"/>	
Payment Type:	<input type="text" value="Free"/>	Order Type:	<input type="text" value="Firm, Fixed"/>
Package Scope:	<input type="text" value="Front File"/>	Breakable:	<input type="checkbox"/>
Estimated Price:	<input type="text"/>	Description:	<input type="text"/>
		Package Type:	<input type="text" value="Consolidated"/>
		Fixed Title List:	<input type="checkbox"/>

Acquisitions Tab Definitions

Title	Description
Material Type	Required. Defines the type(s) of material for reporting and managing different types of resources. Select the Material Type from the dropdown and click <input type="button" value="add"/> .
Format	Required. Defines the format of the e-resource. Select the format from the dropdown and click <input type="button" value="add"/> .
Content Type	Required. Defines the type(s) of content for reporting and managing different types of resources. Select the Content Type from the dropdown and click <input type="button" value="add"/> .
Payment Type	Type of payment for the E-Resource. Examples may include free, paid, includes print, etc..
Package Scope	In a future release, this will be reflected from GOKb.
Estimated Price	The estimated price of the E-Resource used for reference. Once the Purchase Order exists, the estimated price will reflect the official price.
Order Type	Indicates the type of order, for example subscription or standing. Select the Order Type from the dropdown menu.
Breakable	Indicates whether an individual title linked to the E-Resource can be cancelled.
Package Type	In a future release, this will be reflected from GOKb.
Fixed Title List	Indicates whether an E-Resource is static (fixed) or has titles added/removed over time (not fixed).
Description	Text field to allow staff to explain what is being purchased.

Selection Tab

The **Selection** tab gives information about who has requested the E-Resource.

Selection

Requestor	<input type="text"/>	Actions	<input type="button" value="add"/>	
Selector	<input type="text"/>	Actions	<input type="button" value="add"/>	
Requestor/Selector Comment	<input type="text"/>		Actions	<input type="button" value="add"/>
Priority:	1			

Selection Tab Definitions

Title	Description
Requestor	The patron requesting the E-Resource. Enter a valid patron or search for them from the lookup and click <input type="button" value="add"/> .
Selector	The librarian requesting the E-Resource. Enter a valid person or search for them from the lookup and click <input type="button" value="add"/> .
Requestor/Selector Comment	Enter any patron or staff notes about the request and click <input type="button" value="add"/> .
Priority	Select a value from the dropdown to assign a priority value.

Access Tab

The **Access** tab describes the type of access and requirements for the E-Resource.

Access

Type of Access:	site-wide	Authentication Type:	IP range	No. of Simultaneous User:	<input type="text"/>
Access Location:	Main Campus Low Campus High Campus	Statistical Code:	<input type="text"/>		
Technical Requirements:		<input type="text"/>			

Access Tab Definitions

Title	Description
Type of Access	Select the type of access for the E-Resource from the dropdown.
Access Location	Select all of the locations that have access to the E-Resource from the list. Press shift+click or shift+arrow keys to select multiple options.
Authentication Type	Select the type of authentication needed for the E-Resource from the dropdown.
Statistical Code	Select the Statistical Code from the dropdown list.
No. of Simultaneous Users	Enter the number of simultaneous users allowed to have access the E-Resource at the same time.

Technical Requirements

Enter additional notes about technical restrictions/requirements.

Note Tab

The **Note** tab allows staff to record special notes about the E-Resource. For example breaches or computer usage requirements. Click  to add a note in the **Note** subtab.

In the Public Display Note field, staff may record notes that should be displayed to all public users for all titles in the E-Resource.



The screenshot shows a tab labeled 'Note' with a dropdown arrow. Below the tab is a form with a 'Note' label and a text input field. To the right of the input field is an 'Actions' column with an 'add' button. Below this is a 'Public Display Note:' label and another text input field.

Instance Menu

From the **Instance** menu staff can view and update the OLE Instances linked to the E-Resource. In a later release, staff will also be able to manage the relationship between the E-Resource Record and data imported from GOKb.

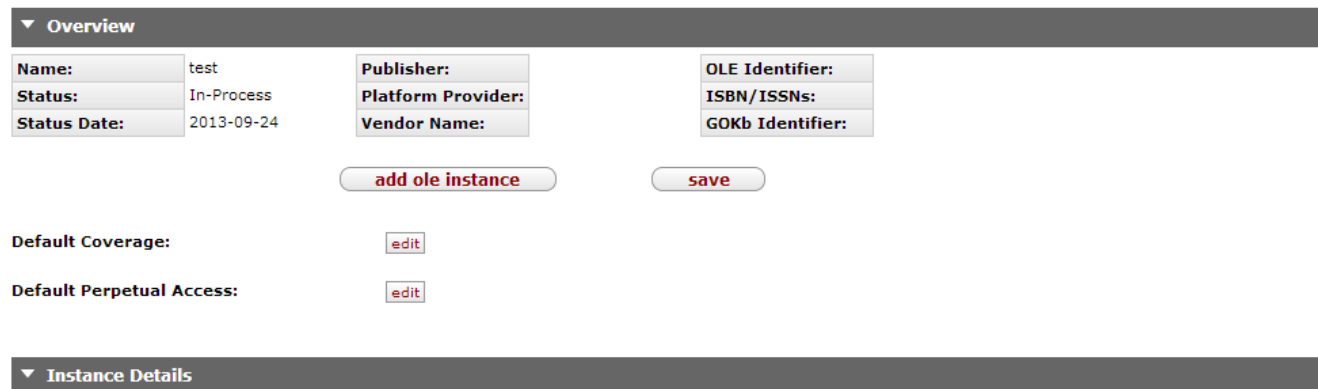



The screenshot shows an 'Overview' tab with a dropdown arrow. Below it are three columns of fields: 'Name: test', 'Status: In-Process', 'Status Date: 2013-09-24'; 'Publisher:', 'Platform Provider:', 'Vendor Name:'; and 'OLE Identifier:', 'ISBN/ISSNs:', 'GOKb Identifier:'. Below these are buttons for 'add ole instance' and 'save'. Further down are 'Default Coverage:' and 'Default Perpetual Access:' with 'edit' buttons.

Overview Tab

The **Overview** tab maintains the same information as the **Main** tab's **Overview** subtab.

Note

See the [Main Overview subtab](#) to review the Overview subtab.

Users may set **Default Coverage** by clicking . A **Coverage** window will open. Enter the coverage information and click .

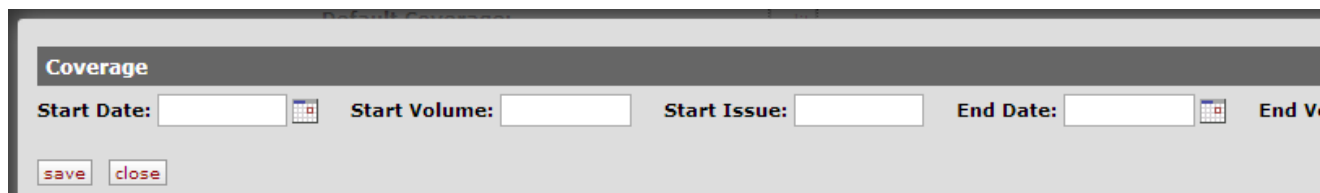

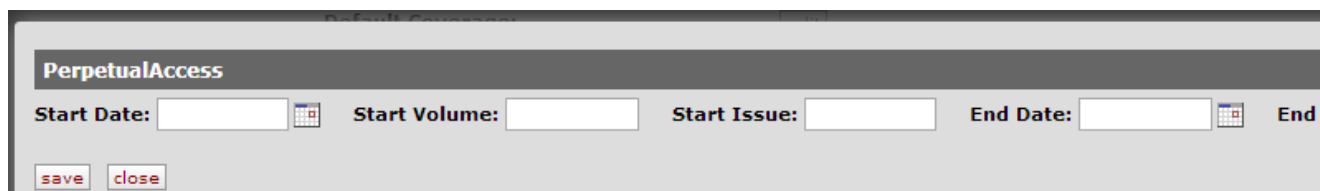

Users may set **Default Perpetual Access** by clicking . A **Perpetual Access** window will open. Enter the access information and click .



OLE Instances Tab

From the **Instance** tab, staff may link a pre-existing OLE Instance or create a new OLE Instance.

1. Click the  button.
2. Select **Link Instance** to link a pre-existing OLE Instance.

A search bar appears with the lookup . Enter the OLE Instance ID or search for the OLE Instance from the lookup.

3. Otherwise, select **Create OLE Instance** to open the Bib Editor.

Note

For more information about the [Bibliographic Editor](#), see the relevant section in the *OLE Guide to Describe*.

4. Click **Save** to load the OLE Instance.

Instances will appear in the **Instance Details** subtab.

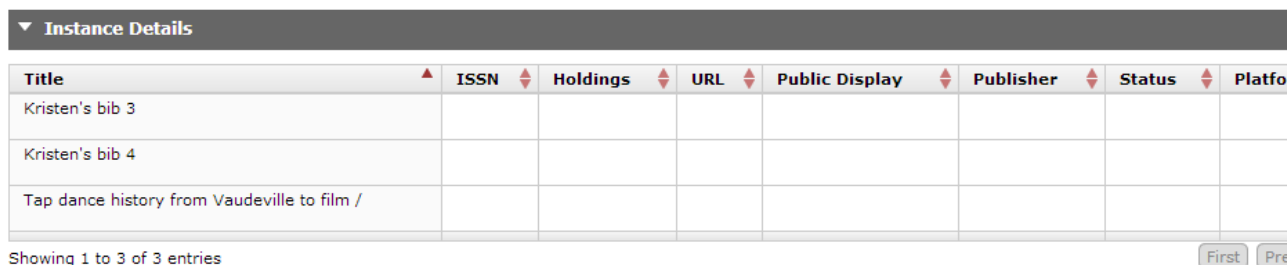

Title	ISSN	Holdings	URL	Public Display	Publisher	Status	Platform
Kristen's bib 3							
Kristen's bib 4							
Tap dance history from Vaudeville to film /							

Purchase Order Menu

From the **Purchase Order** menu, staff are able to view and update the linked Purchase Orders of the E-Resource.

▼ Overview				
Name:	Kristen's e-resource	Publisher:	Kristen's publisher	OLE Identifier: 1
Status:	In-Process	Platform Provider:		ISBN/ISSNs:
Status Date:	2013-09-23	Vendor Name:	YBP Library Services	GOKb Identifier:

▼ PO details				
PO Item Id	Title	Paid Amount CurrentFY	Paid Amount PreviousFY	Paid Amount Two Years PreviousFY
1102	Kristen's bib 4	0		

Overview Tab

The **Overview** tab maintains the same information as the **Main** menu's **Overview** tab.

Note

See the [Main Overview subtab](#) to review the Overview subtab.

PO Details

The **PO Details** tab displays the PO information.

Note

To learn more about creating [Purchase Orders](#), see the relevant section in *OLE's Guide to Select and Acquire*.

License Menu

From the **License** menu staff can view and create licenses to link to the E-Resource.

▼ Overview				
Name:	Kristen's e-resource	Publisher:	Kristen's publisher	OLE Identifier: 1
Status:	In-Process	Platform Provider:		ISBN/ISSNs:
Status Date:	2013-09-23	Vendor Name:	YBP Library Services	GOKb Identifier:

[start new license](#)

▼ Licenses					
DocumentId	Licensor	Licens Request Status	License Request Last Modified Date	License Title	Attachments
3648		License Needed	09/20/2013 09:47 AM	New OleLicenseRequestBo - LicenseNeeded-REQS_[date:2013-09-20]	No Attachments

Overview

The **Overview** tab maintains the same information as the **Main** menu's **Overview** tab.

Note

See the [Main Overview subtab](#) to review the Overview subtab.

License

From the **License** tab, staff may start a new license request. Click the button to open the **License Request** document.

start new license

Note

For more on creating license requests, see [below](#)

Once a License Request has been started, License information will appear in this subtab. The information includes the Licensor, Status of the License Request, Last Modified Date, License Title, Attachments, License Create Date and License End Date.

▼ Licenses						
DocumentId	Licensor	Licens Request Status	License Request Last Modified Date	License Title	Attachments	License Date
3648		License Needed	09/20/2013 09:47 AM	New OleLicenseRequestBo - LicenseNeeded-REQS_[date:2013-09-20]	No Attachments	

Event Log Menu

The **Event Log** menu is available to store the correspondence between librarians and publishers, vendors, and others. Libraries may also use the Event Log to record an audit trail of changes made to the E-Resource Record.

▼ Overview					
Name:	Kristen's e-resource	Publisher:	Kristen's publisher	OLE Identifier:	1
Status:	In-Process	Platform Provider:		ISBN/ISSNs:	
Status Date:	2013-09-23	Vendor Name:	YBP Library Services	GOKb Identifier:	

save

▼ Event Log				
add				
Type	Event Date	* User:	ole-khuntley	* Note:
add				

Show entries Search:

Type	Event Date	User	Note
System	09/20/2013 09:38 AM	ole-khuntley	status is In-Process
System	09/20/2013 10:14 AM	ole-khuntley	Kristen's bib (Instance Id : wen-4) was removed

Showing 1 to 2 of 2 entries

Overview Tab

The **Overview** tab maintains the same information as the **Main** menu's **Overview** tab.

Note

See the [Main Overview subtab](#) to review the Overview tab.

Event Log Tab

The **Event Log** tab captures automated entries for E-Resource workflows. Users can also manually add entries to capture external communications, notes, or to summarize any actions external to OLE (such as with Vendor/Provider, University Legal, University Purchasing, etc.). You may add an event by filling out the required fields and clicking .

Many events can be recorded in the event log. You may display 10, 25, 50, or 100 entries at one time. Additionally, you may search for events from the search bar.

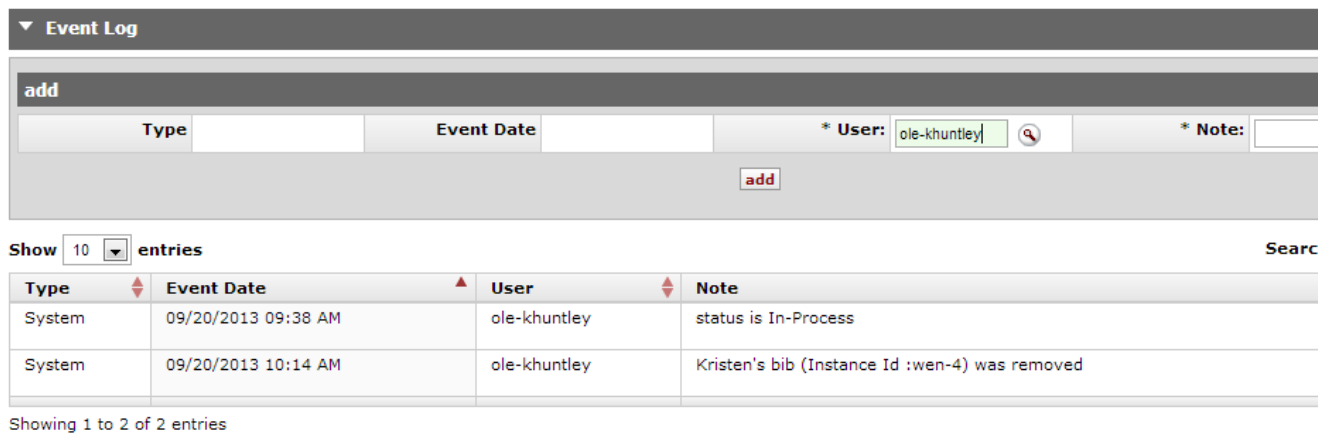

The screenshot shows the 'Event Log' interface. At the top, there is a header 'Event Log' with a dropdown arrow. Below it is a form to add a new event. The form has fields for 'Type', 'Event Date', '* User:' (with a search icon and the value 'ole-khuntley'), and '* Note:'. There is an 'add' button below the form. Below the form, there is a 'Show' dropdown set to '10' and the text 'entries'. To the right is a 'Search' button. Below this is a table with the following columns: 'Type', 'Event Date', 'User', and 'Note'. The table contains two entries:

Type	Event Date	User	Note
System	09/20/2013 09:38 AM	ole-khuntley	status is In-Process
System	09/20/2013 10:14 AM	ole-khuntley	Kristen's bib (Instance Id :wen-4) was removed

Below the table, it says 'Showing 1 to 2 of 2 entries'.

Event Log Subtab Definitions

Title	Description
Type	System generated. The event type value will be 'system' when the request is initiated, 'user' if a line was added manually by user; 'file' if an Agreement doc was added; 'agreement' if a linked Agreement document was edited or added; 'location' if a location change occurred; 'status' if a license status change occurred.
Event Date	System generated. Logs the date for the event log line item.
User	Required. Logs the user id of the person associated with the event log change. Defaults to current user but can be modified by entering a name or searching from the lookup  .
Note	Required; may be manually added or system generated. Users may input information to provide audit trail information. System also records what events have occurred.

Process Overview

1. Select **E-Resource** from the **Select/Acquire** Menu.
2. Fill in data in the required fields: Name, Status, Material type, Payment Type, Content Type and Format.

3. Enter additional information and click  .
4. From this point the E-Resource acquisition process is non-linear. Four different workflows may be set in motion in any sequence.

- Trials (in a future release)
- License

Note

For more on creating license requests, see [below](#)

- Purchasing through a Requisition and Purchase Order (in a future release)
- Activate patron access (in a future release)

As the E-Resource Record is passed through each workflow, the document is editable for staff to add or modify as necessary.

5. Click  to move the document to the next approver.

Business Rules

- E-Resource must have required fields specified in Data Requirements worksheet in order to be saved.
- A License Request will be linked to an E-Resource, not a Requisition (this is a change from 0.8).
- An Instance may only be linked to one E-Resource.
- An E-resource has locally defined “ownership” groups or individuals. Only one group may “own” an E-Resource Record at a time.
- E-Resource Records remain in the Action List of the “owning group” until passed to the next owning group, a locally defined sequence. Whenever an E-Resource’s workflow has been completed by the last defined owning group it no longer appears in any group’s Action List.

Routing

E-Resource Search



Search E-Resource Records

OLE offers a customized document search related to E-Resources. Once you have opened the **E-Resource Search**, perform a search to find the record you wish to modify.

Note

For information about **Search By** fields that are specific to E-Resources, see the E-Resource's [“Document Layout”](#) .

Process Overview

Search E-Resource Records

Search By: <input type="text"/>	Search Criteria: <input type="text"/>	▼ Filters Status Date(mm/dd/yy): Begin: <input type="text"/> ▼ Status <input type="checkbox"/> In-Process <input type="checkbox"/> Canceled
	<input checked="" type="radio"/> AND <input type="radio"/> OR <input type="radio"/> NOT	
Search By: <input type="text"/>	Search Criteria: <input type="text"/>	
	<input checked="" type="radio"/> AND <input type="radio"/> OR <input type="radio"/> NOT	
Search By: <input type="text"/>	Search Criteria: <input type="text"/>	
	<input checked="" type="radio"/> AND <input type="radio"/> OR <input type="radio"/> NOT	

You may select what you would like to **Search by** and search using Boolean operators as needed. You may also filter by dates and statuses using the box on the right side of the screen. Search results appear below the **Search** boxes.

Search E-Resource Records

Search By: <input type="text"/>	Search Criteria: <input type="text"/>	▼ Filters Status Date(mm/dd/yy): <input type="text"/> Begin: <input type="text"/> <input type="text"/> End: <input type="text"/> ▼ Status <input type="checkbox"/> In-Process <input type="checkbox"/> Trial <input type="checkbox"/> Ordered <input type="checkbox"/> <input type="checkbox"/> Canceled
	<input checked="" type="radio"/> AND <input type="radio"/> OR <input type="radio"/> NOT	
Search By: <input type="text"/>	Search Criteria: <input type="text"/>	
	<input checked="" type="radio"/> AND <input type="radio"/> OR <input type="radio"/> NOT	
Search By: <input type="text"/>	Search Criteria: <input type="text"/>	
	<input checked="" type="radio"/> AND <input type="radio"/> OR <input type="radio"/> NOT	

Show entries

DocID	E-Resource Identifier	E-Resource Record Name	Publisher	Platform Provider Name	E-Resource Record Date
3615	1	Kristen's e-resource	Kristen's publisher		2013-09-20
4847	2	Ashok Kumar			2013-09-23
6302	3	Project Muse			2013-09-24

Showing 1 to 3 of 3 entries

You may display 10, 25, 50, or 100 E-Resource Record entries at one time. Additionally, you may further refine your search from the search bar above the results.

Click a **Doc ID** to open the E-Resource record.

Chapter 8. COA Attribute Maintenance E-Docs



On the **Select/Acquire** menu tab, the **Chart of Accounts** submenu provides access to numerous maintenance documents for your institution's charts.

Constraint Type

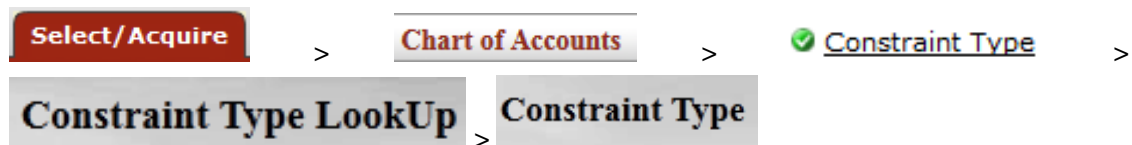

The Constraint Type identifies the type of constraint for sufficient fund checking on the Account e-document, i.e. “over” or “under”.

Document Layout

The screenshot displays the 'Constraint Type' document layout. At the top, there is a header bar with 'Constraint Type' and a help icon. Below this, the document is organized into several sections:

- Document Overview:** Contains fields for '* Description:', 'Organization Document Number:', and 'Explanation:'.
- Edit Document Type:** Contains fields for '* Constraint Type:' and 'Active Indicator:' (with a checked checkbox).
- Notes and Attachments (0):** Includes a 'show' button.
- Ad Hoc Recipients:** Includes a 'show' button.
- Route Log:** Includes a 'show' button.

At the bottom of the form, there are buttons for 'submit', 'save', 'blanket approve', 'close', and 'cancel'.

The Constraint document includes the **Edit Document Type** tab. The system automatically enters data into both the **Old** and **New** sections. Selected data fields are available for editing.

Edit Document Type tab definition

Title	Description
Constraint Type	Identifies the type of constraint, i.e. "over" or "under"
Active Indicator	Indicates whether this constraint type is active or inactive. Remove the check mark to deactivate a code.

Fund Group

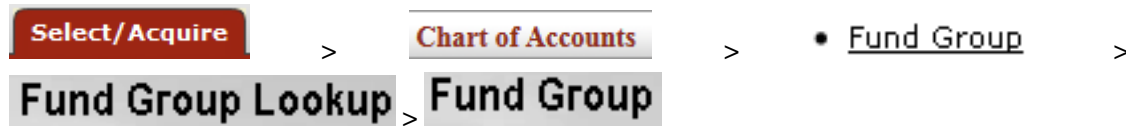

The Fund Group document is used to define the broadest category of funds and is used for reporting and business rules. Examples of fund groups include General Funds and Contracts and Grants Funds. Although fund group is the broadest category of funds, it is an attribute of a narrower group: sub-fund. For example, accounts have an assigned sub-fund and from that sub-fund a fund group is retrieved.

Document Layout

Fund Group ?

Doc Nbr: 3307
Initiator: khuntle

Document Overview ▼ hide

* Description: <input type="text"/>	Explanation: <input type="text"/>
Org. Doc. #: <input type="text"/>	

Edit Fund Group Code ▼ hide

Old	New
Fund Group Code: CG	Fund Group Code: CG
Fund Group Name: CONTRACT & GRANTS	* Fund Group Name: CONTRAC
Financial Reporting Sort Code: 04	* Financial Reporting Sort Code: <input type="text" value="04"/>
Budget Adjustment Restriction Code: Fund	* Budget Adjustment Restriction Code: <input type="text" value="Fund"/>
Active Indicator: Yes	Active Indicator: <input checked="" type="checkbox"/>

Notes and Attachments (0) ▶ show

Ad Hoc Recipients ▶ show

Route Log ▶ show

submit
save
blanket approve
close
cancel

The Fund Group document includes the **Edit Fund Group Code** tab. The system automatically enters data into both the **Old** and **New** sections. Selected data fields are available for editing.

Edit Fund Group tab definition

Title	Description
Fund Group Code	The code to uniquely identify a specific fund group.
Fund Group Name	Required. The descriptive label of this specific fund group.
Financial Reporting Sort Code	Required. The code to place fund groups in a particular sequence on reports
Budget Adjustment Restriction Code	Required. The code to define the level at which business rules on the budget adjustment document are checked. Existing budget adjustment restriction code may be retrieved from the lookup  and are: F = Fund C = Chart O = Organization A = Account
Active Indicator	Indicates whether this fund group code is active or inactive. Remove the check mark to deactivate a fund group code.

Object Consolidation



The Object Consolidation document defines a general category of object codes for reporting. One object consolidation includes the object codes belonging to one or more object levels.

Document Layout

Object Consolidation ?

Doc Nbr: 3322
Initiator: khuntle

Document Overview
▼ hide

* Description: <input style="width: 95%;" type="text"/>	Explanation: <input style="width: 95%;" type="text"/>
Org. Doc. #: <input style="width: 80%;" type="text"/>	

Object Consolidation
▼ hide

Old	New
Chart Code: BA	Chart Code: BA
Consolidation Code: CMPN	Consolidation Code: CMPN
Consolidation Object Short Name: COMPENS	* Consolidation Object Short Name: <input style="width: 95%;" type="text" value="COMPENS"/>
Consolidation Object Name: COMPENSATION	* Consolidation Object Name: <input style="width: 95%;" type="text" value="COMPENS"/>
Active Indicator: Yes	Active Indicator: <input checked="" type="checkbox"/>
Reporting Sort Code: 07	* Reporting Sort Code: <input style="width: 80%;" type="text" value="07"/>

Notes and Attachments (0) ▶ show

Ad Hoc Recipients ▶ show

Route Log ▶ show

submit
save
blanket approve
close
cancel

The Object Consolidation document includes the **Edit Object Consolidation** tab. The system automatically enters data into both the **Old** and **New** sections. Selected data fields are available for editing.

Object Consolidation tab definition

Title	Description
Chart Code	The chart code for the associated object consolidation.
Consolidation Code	A consolidation code associated with object codes assigned to a particular reporting group of object levels.
Consolidation Object Short Name	Required. An abbreviated name used in reporting where space is limited.
Consolidation Object Name	Required. A descriptive label of this specific object consolidation group.
Active Indicator	Indicates whether this object consolidation code is active or inactive. Remove the check mark to deactivate.
Reporting Sort Code	Required. The code that determines the default sort sequence on reports.

Object Level

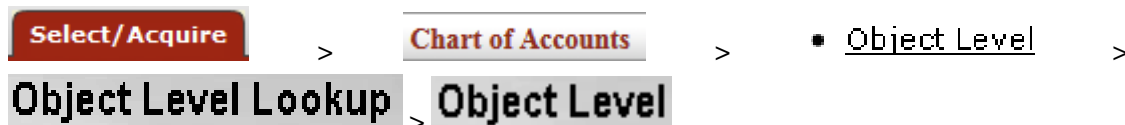

The Object Level document is used to maintain an attribute of the object code that is used to group similar object codes into categories for reporting.

Document Layout

Object Level ?

Doc Nbr: 3323
Initiator: khuntle

▼ hide

Document Overview

* Description: <input type="text"/>	Explanation: <input type="text"/>
Org. Doc. #: <input type="text"/>	

▼ hide

Old	New
Chart Code: BA	Chart Code: BA
Level Code: ACLI	Level Code: ACLI
Object Level Name: ACCRUED LIABILITIES	* Object Level Name: <input type="text" value="ACCRUED"/>
Object Level: ACCR LIAB	* Object Level: <input type="text" value="ACCR LIAB"/>
Consolidation Code: LIAB	* Consolidation Code: <input type="text" value="LIAB"/>
Active Indicator: Yes	Active Indicator: <input checked="" type="checkbox"/>
Report Sort Code: RK	* Report Sort Code: <input type="text" value="RK"/>

Notes and Attachments (0) ▶ show

Ad Hoc Recipients ▶ show

Route Log ▶ show

submit
save
blanket approve
close
cancel

The Object Level document includes the **Edit Object Level** tab. The system automatically enters data into both the **Old** and **New** sections. Selected data fields are available for editing.

Edit Object Level tab definition

Title	Description
Chart Code	The chart code for the associated object level
Level Code	The code assigned to a particular reporting level of object codes.
Object Level Name	Required. A descriptive label for this specific object level.
Object Level	Required. An abbreviated name for this level to be used in reporting where space is limited.
Consolidation Code	Required. The consolidation object code associated with this object level code. Existing consolidation codes may be retrieved from the lookup
Active Indicator	Indicates whether this object level code is active or inactive. Remove the check mark to deactivate this code.
Report Sort Code	Required. The code that determines the default sort sequence on reports.

Object Sub-Type



The Object Sub-Type document is used to further refine object type. Object sub-type can be used for reporting and in some instances for the establishment of business rules on e-docs (for example, a document might restrict the use of object codes belonging to a certain object sub-type).

Document Layout

Object Sub-Type ?		Doc Nbr: 3324
		Initiator: khuntle

Document Overview ▼ hide

Document Overview

* Description:	<input type="text"/>	Explanation:	<input type="text"/>
Org. Doc. #:	<input type="text"/>		

Edit Object Sub-Type ▼ hide

Old		New	
Object Sub-Type Code:	AR	Object Sub-Type Code:	AR
Object Sub-Type Name:	ACCOUNTS RECEIVABLE	* Object Sub-Type Name:	ACCOUNTS RECEIVABLE
Active Indicator:	Yes	Active Indicator:	<input checked="" type="checkbox"/>

Notes and Attachments (0) ▶ show

Ad Hoc Recipients ▶ show

Route Log ▶ show

submit save blanket approve close cancel

The Object Sub-Type document includes the **Edit Object Sub-Type** tab. The system automatically enters data into both the **Old** and **New** sections. Selected data fields are available for editing.

Edit Object Sub Type tab definition

Title	Description
Object Sub-Type Code	The code assigned to a particular subdivision of an object type.
Object Sub-Type Name	Required. A descriptive label for this specific object sub-type.
Active Indicator	Indicates whether this object sub type code is active or inactive. Remove the check mark to deactivate this code.

Object Type



The Object Type document defines the general use of an object code; such as income, asset, expense, or liability.

Tip

When you are configuring the object types, it is important to cross-reference the Object Type table, the System Options table and the OBJECT_TYPES parameters in the Parameter table.

Document Layout

Object Type ?

Doc Nbr: 3325
Initiator: khuntle

Document Overview
▼ hide

Document Overview

* Description: <input style="width: 95%;" type="text"/>	Explanation: <input style="width: 95%;" type="text"/>
Org. Doc. #: <input style="width: 80%;" type="text"/>	

Edit Object Type
▼ hide

Old	New
Object Type Code: AS	Object Type Code: AS
Object Type Name: ASSET	* Object Type Name: ASSET
Object Type Debit Credit Code: Debit	* Object Type Debit Credit Code: Debit ▼
ICR Selection Indicator: No	ICR Selection Indicator: <input type="checkbox"/>
Fund Balance Indicator: No	Fund Balance Indicator: <input type="checkbox"/>
Reporting Sort Code: C1	* Reporting Sort Code: C1
Basic Accounting Category: AS - ASSETS	* Basic Accounting Category: AS - AS
Active Indicator: Yes	Active Indicator: <input checked="" type="checkbox"/>

Notes and Attachments (0)
▶ show

Ad Hoc Recipients
▶ show

Route Log
▶ show

submit
save
blanket approve
close
cancel

The Object Type document includes the **Edit Object Type** tab. The system automatically enters data into both the **Old** and **New** sections. Selected data fields are available for editing.

Edit Object Type tab definition

Title	Description
-------	-------------

Object Type Code	The code assigned to a particular object type.
Object Type Name	Required. A descriptive label for this object type code.
Object Type Debit Credit Code	Required. The default accounting balance type of debit or credit for the object code that is retrieved from the list.
ICR Selection Indicator	The box is checked when the transactions with the object type are eligible for automated indirect cost calculation.
Fund Balance Indicator	The box is checked when the object type code is used in the fund balance.
Reporting Sort Code	Required. The code that determines the default sort sequence of object types on certain reports.
Basic Accounting Category Code	Required. The basic accounting category code that groups object type codes for use in reporting and business processes throughout the system. Existing basic accounting category codes may be retrieved from the list or the lookup  .
Active Indicator	Indicates whether this object type code is active or inactive. Remove the check mark to deactivate this code.

Restricted Status

Select/Acquire > Chart of Accounts > Restricted Status > Restricted Status Lookup > Restricted Status

The Restricted Status document is used to define whether the funds within an account are restricted, unrestricted, temporarily restricted or not applicable. Some OLE business rules refer to Restricted Status records when determining the validity of an e-doc transaction.

Document Layout

Restricted Status 
Kuali Financial System

Doc Nbr: 3335

Initiator: kggodf

Document Overview



* Description: <input type="text"/>	Explanation: <input type="text"/>
Org. Doc. #: <input type="text"/>	

Edit Restricted Status

Old	New
Restricted Status Code: R	Restricted Status Code: R
Restricted Status Name: RESTRICTED	* Restricted Status Name: RESTRICTED
Active Indicator: Yes	Active Indicator: <input checked="" type="checkbox"/>

Notes and Attachments (0)

Ad Hoc Recipients

Route Log

submit save blanket approve close cancel

The Restricted Status document includes the **Edit Restricted Status** tab. The system automatically enters data into both the **Old** and **New** sections. Selected data fields are available for editing.

Edit Restricted Status tab definition

Title	Description
Restricted Status Code	The unique code that identifies a particular restricted status.
Restricted Status Name	Required. The descriptive name for this restricted status code.
Active Indicator	Indicates whether this restricted status code is active or inactive. Remove the check mark to deactivate this restrictive status code.

Stewardship Requirement



The Stewardship Requirement document is used to indicate the type of stewardship on an account e-document, for example some stewardship requirements are bookplates, annual reports for donors or departments.

Document Layout

Stewardship Requirement ?

Doc Nbr	
Initiator	

Document Overview hide

Document Overview

* Description:

Organization Document Number:

Explanation:

Edit Stewardship Requirement hide

Old	New
Stewardship Type: None	* Stewardship Type: None
Active Indicator: Yes	Active Indicator: <input checked="" type="checkbox"/>

Notes and Attachments (0) show

Ad Hoc Recipients show

Route Log show

The Stewardship Requirement document includes the **Edit Stewardship Requirement** tab. The system automatically enters data into both the **Old** and **New** sections. Selected data fields are available for editing.

Edit Stewardship Type tab definition

Title	Description
Stewardship Type	Identifies the type of stewardship, i.e., none, plating, reporting
Active Indicator	Indicates whether this sub fund group type code is active or inactive. Remove the check mark to deactivate this code.

Sub-Fund Group



The Sub-Fund Group document defines the type, purpose or source of funds that are found in that account. Sub-fund group may be used for reporting purposes and for business rules on OLE e-docs.

Document Layout

Sub-Fund Group ?		Doc Nbr: 3336
		Initiator: kqgodfre

Document Overview hide

Document Overview

* Description:	<input type="text"/>	Explanation:	<input type="text"/>
Org. Doc. #:	<input type="text"/>		

Edit Sub-Fund Group hide

Old		New	
Sub-Fund Group Code:	EXTAGY	Sub-Fund Group Code:	EXTAGY
Description:	EXTERNAL AGENCY FUNDS	* Description:	EXTERNAL AGENCY FUNDS
Fund Group Code:	AF	* Fund Group Code:	AF <input type="text"/>
Active Indicator:	Yes	Active Indicator:	<input checked="" type="checkbox"/>
Sub-Fund Group Type Code:	N - NEITHER	* Sub-Fund Group Type Code:	N - NEITHER <input type="text"/>
Default Account Restricted Status Code:		Default Account Restricted Status Code:	<input type="text"/>
Financial Reporting Sort Code:	38	* Financial Reporting Sort Code:	38 <input type="text"/>
Wage Indicator:	Yes	Wage Indicator:	<input checked="" type="checkbox"/>
Budget Adjustment Restriction Code:	None	* Budget Adjustment Restriction Code:	None <input type="text"/>

Notes and Attachments (0) show



Ad Hoc Recipients show

Route Log show

The Sub-Fund Group document includes the **Edit Sub-Fund Group** tab. The system automatically enters data into both the **Old** and **New** sections. Selected data fields are available for editing.

Edit Sub-Fund Group tab definition

Title	Description
Sub-Fund Group Code	The unique code that identifies a particular sub-fund group.

Description	Required. The descriptive name for this sub-fund group code.
Fund Group Code	Required. The larger fund group to which the sub-fund group is associated. Existing fund group codes may be retrieved from the lookup  .
Active Indicator	Indicates whether this sub fund group code is active or inactive. Remove the check mark to deactivate this code.
Sub Fund Group Type Code	Required. A code that identifies the sub-fund group type. Existing types may be retrieved from the list or from the lookup  . Examples include: 'Auxiliary,' 'Internal Service Organizations,' or 'Neither.'
Default Account Restricted Status Code	A unique code that identifies a particular restricted status for the default account. Existing restricted status codes may be retrieved from the list or from the lookup  .
Financial Reporting Sort Code	Required. A code that designates the default sort sequence on reports.
Wage Indicator	The box checked when the sub-fund group is one that is expected to pay compensation expenses.
Budget Adjustment Restriction Code	Required. The code that determines at what level OLE checks for restrictions when an account of the sub-fund group is used on a Budget Adjustment e-doc from the budget adjustment restriction code list. Values retrievable from the list include: N = None S = Sub-Fund C = Chart O = Organization A = Account

Sub-Fund Group Type



The Sub-Fund Group Type document defines further categorization of sub-funds. Common sub-fund group types include 'Auxiliary,' 'Internal Service Organization,' or 'Neither.'

Document Layout

Sub-Fund Group Type		Doc Nbr: 3337
		Initiator: kqgodfre

Document Overview ▼ hide

Document Overview	
* Description: <input type="text"/>	Explanation: <input type="text"/>
Org. Doc. #: <input type="text"/>	

Edit Sub-Fund Group Type ▼ hide

Old	New
Sub-Fund Group Type Code: A	Sub-Fund Group Type Code: A
Sub-Fund Group Type Description: AUXILIARY	* Sub-Fund Group Type Description: AUXILIARY
Active Indicator: Yes	Active Indicator: <input checked="" type="checkbox"/>

Notes and Attachments (0) ▶ show

Ad Hoc Recipients ▶ show

Route Log ▶ show

submit save blanket approve close cancel

The Sub-Fund Group Type document includes the **Edit Sub-Fund Group Type** tab. The system automatically enters data into both the **Old** and **New** sections. Selected data fields are available for editing.

Edit Sub Fund Group Type tab definition

Title	Description
Sub-Fund Group Type Code	A unique code that identifies the sub-fund group type.
Sub-Fund Group Type Description	Required. The descriptive name for this sub-fund group type code.
Active Indicator	Indicates whether this sub fund group type code is active or inactive. Remove the check mark to deactivate this code.

Sufficient Funds Code



The Sufficient Funds Code document defines the codes that indicate what level the account is checked for sufficient funds in the transaction processing environment. The values are pre-determined within the system. The name of the code may be edited or the code may be deactivated.

Document Layout

Sufficient Funds Code ?

Doc Nbr: 3338
Initiator: kqqodf

Document Overview
▼ hide

* Description: <input style="width: 95%;" type="text"/>	Explanation: <input style="width: 95%;" type="text"/>
Org. Doc. #: <input style="width: 80%;" type="text"/>	

Edit Sufficient Fund Code
▼ hide

Old	New
Account Sufficient Funds Code: A	Account Sufficient Funds Code: A
Account Sufficient Funds Name: Account	* Account Sufficient Funds Name: Account
Active Indicator: Yes	Active Indicator: <input checked="" type="checkbox"/>

Notes and Attachments (0) ▶ show

Ad Hoc Recipients ▶ show

Route Log ▶ show

submit
save
blanket approve
close
cancel

The Sufficient Funds Code document includes the **Edit Sufficient Funds Code** tab. The system automatically enters data into both the **Old** and **New** sections. Selected data fields are available for editing.

Edit Sufficient Funds Code tab definition

Title	Description
Account Sufficient Funds Code	Display-only. A unique code that indicates what level the account is going to be checked for sufficient funds in the transaction processing environment. The values defined by the system are: A = Account C = Consolidation H = Cash L = Level N = No Checking O = Object Code
Account Sufficient Funds Name	Required. The descriptive name for the account sufficient funds code.
Active Indicator	Indicates whether this sufficient funds code is active or inactive. Remove the check mark to deactivate this code.

Sufficient Funds Check Type

Select/Acquire

>

Chart of Accounts

>

✔

Sufficient Funds Check Type

>

Sufficient Funds Check Type LookUp

>

Sufficient Funds Check Type

The Sufficient Funds Check Type is used to define the type of sufficient fund check performed on the Account e-document.

Document Layout

Sufficient Funds Check Type ?		Doc Nbr
		Initiator
Document Overview hide		
Document Overview		
* Description:	<input type="text"/>	Explanation: <input type="text"/>
Organization Document Number:	<input type="text"/>	
Edit Sufficient Funds Check Type hide		
New		
* Sufficient Funds Check Type:	<input type="text"/>	
Active Indicator:	<input checked="" type="checkbox"/>	
Notes and Attachments (0)	show	
Ad Hoc Recipients	show	
Route Log	show	
<input type="button" value="submit"/> <input type="button" value="save"/> <input type="button" value="blanket approve"/> <input type="button" value="close"/> <input type="button" value="cancel"/>		

The Sufficient Funds Check Type document includes the **Edit Sufficient Funds Check Type** tab. The system automatically enters data into both the **Old** and **New** sections. Selected data fields are available for editing.

Edit Sufficient Funds Check Type tab definition

Title	Description
Sufficient Funds Check Type	Identifies the type of fund to check, i.e., "account", "object", "cash"
Active Indicator	Indicates whether this sufficient funds code is active or inactive. Remove the check mark to deactivate this code.

Chapter 9. Standard COA E-Docs

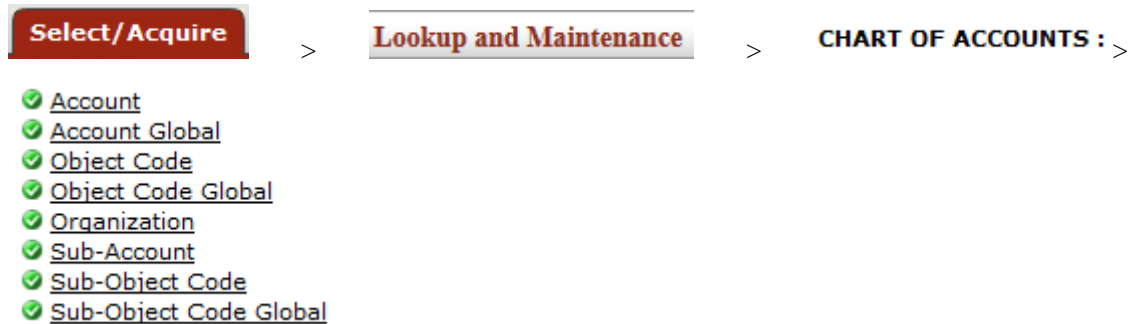

The **Lookup and Maintenance** submenu on the **Select/Acquire** tab offers access to several Chart of Accounts e-docs that allow users to update reference tables that provide key structure for the tracking and storage of financial data.

Managing COA Documents

Kuali OLE relies on a variety of Chart of Accounts (COA) tables to function. These tables define the attributes and values used by the system to validate transactions. They also control the often complex relationships between elements in the Chart of Accounts that must be leveraged for internal and external reporting. For example, tables store basic information such as the sub-fund groups to which new accounts may be assigned and the calendar month that correlates to the first month of your institution's fiscal year. This type of flexibility is one of the features that make OLE a highly configurable application.

Tip

A note on language:

OLE/KFS Calls it:	Libraries more often call it (or it equates to):
Account	Fund
Object Code	Material type and/or order type and/or subject
Organization code	school, program, division,
Budget at Account-Object Code	Allocations

This section presents information and instructions for viewing records in the COA tables and using e-docs to maintain these tables.

Note

OLE also delivers a feature to add extension tables if your institution wants or needs to record additional Chart of Accounts attributes that are not part of the base system. OLE extended attributes may be free text fields or may have an associated reference table to supply valid values. The data dictionary can be configured by your technical staff in the following manner:

- An extended attribute displays on the associated e-doc
- An extended attribute can be made required or optional

- An extended attribute can be available as search criteria and/or in the search results in a lookup.

Note

For more information about extended attributes, see [Extended Attributes](#) on the *OLE Maintenance E-Doc Fundamentals* wiki page

Library Subject Matter Experts (SME's) worked with the Core Team to examine and modify all existing structures in Quali Financial Systems to accommodate library financial needs, structures, and attributes for OLE. The OLE Financial module continues to be investigated through the 1.0 release.

Initiating Chart of Account Structures

Note

See: [Appendix- Initializing Chart of Accounts in OLE](#) (requires KIS credentials, see [Getting Started with OLE](#))

This additional document is a work-in-progress guide to library implementations of the Chart of Accounts. It provides guidelines and key definitions of the structures and attributes libraries will need to setup to start using our OLE *fund and budget* structures. It will continue to be posted on Google Docs and updated over time as we append functions for final university payments, Fiscal Year Rollover and university financial integrations.

OLE users are welcome to begin creating a new Chart, Organizations, and CoA structures to test a setup, but are encouraged to default to the OLE "IU-University Chart" as the parent of any new structures (primary object codes defined).

Creating Funds: OLE Chart of Accounts

Chart of Accounts (COA) is the set of controlling tables that define financial information, such as the codes and coding structures within OLE, including attributes like Accounts, Organizations, and Object Codes. The COA module exists primarily to support and validate entries into the General Ledger (G/L).OLE is leveraging the coding, processing and structures of the KFS Chart of Accounts, which includes:

- Fiscal Year, Accounting Period
- Charts
- Account, Fund Group, Sub-Fund Group, Account Global; Account Delegate
 - New: Sufficient Funds checking
- Sub-Account, Financial Reporting Code
- Object Codes, Object Global, Sub-Objects, Sub-Object Global, Object Level/Consolidation
- Organizations, Responsibility Center, Organization Review

- Project Codes
- Chart of Accounts Maintenance Documents (Attributes/Controlled Value Lists)

A Chart is the primary or parent structure, to which 1:N (Many) Organizations belong. Accounts and Object belong to a single Chart. Budgets are then applied to combined Account-Object structures. Accounts may have sub-accounts, and Object may have sub-objects for further division and reporting.

In OLE Library sample Chart, Organization, Account, Object and Budget (using Chart “BL”):

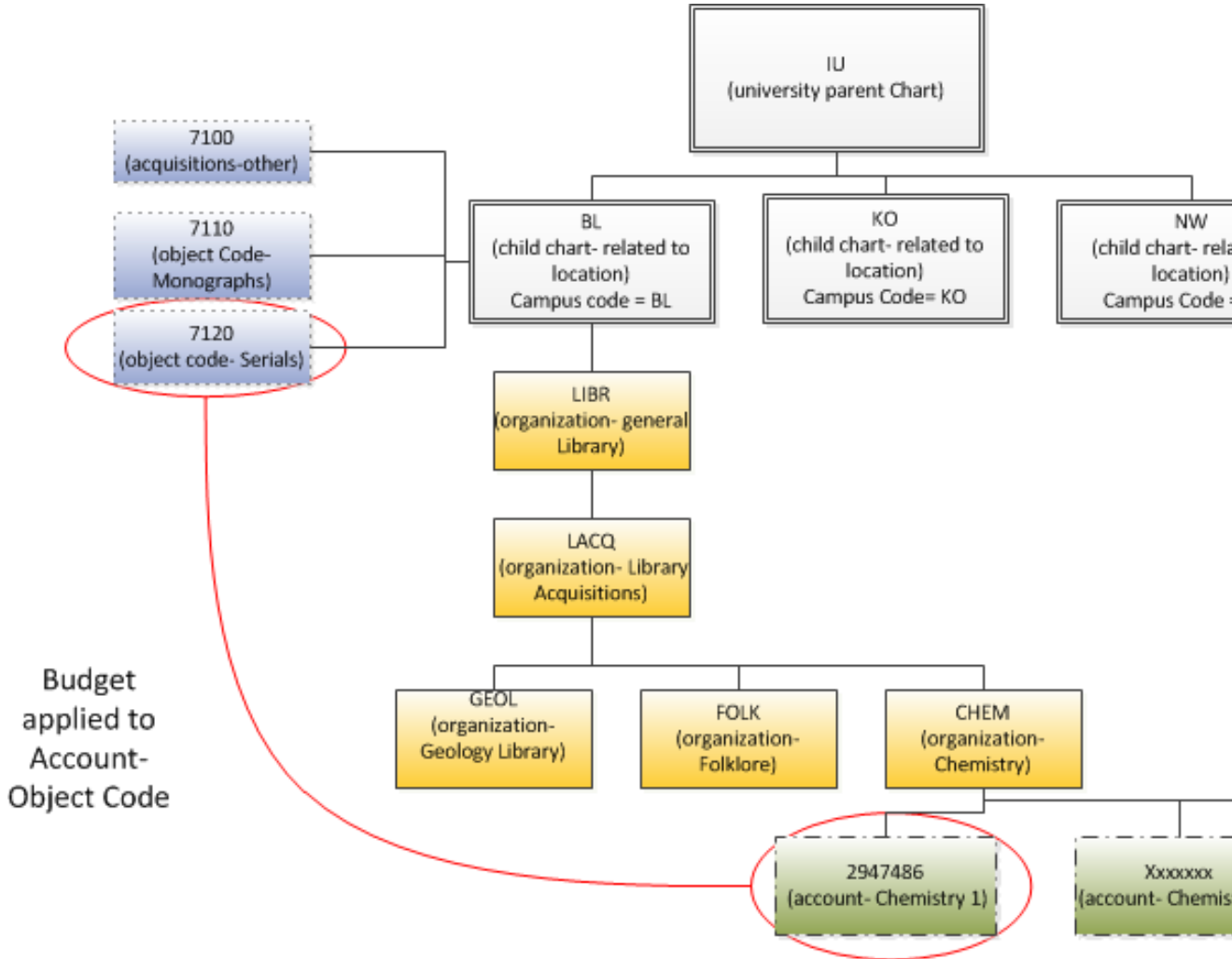

Global COA Documents

Some COA documents (Account, Object Code, and Sub-Object Code) allow you to assign identical values to multiple 'objects' on a single document known as a global document.

To initiate a global document, select the desired document from the **Chart of Accounts** menu group on the **Lookup and Maintenance** submenu on the **Main Menu** tab and enter the appropriate data.

Account Global ?		Doc Nbr:
		Initiator:

Document Overview
▼ hide

Document Overview	
* Description: <input style="width: 95%;" type="text"/>	Explanation: <input style="width: 95%;" type="text"/>
Org. Doc. #: <input style="width: 60%;" type="text"/>	

Global Account Maintenance
▼ hide

New	
Fiscal Officer Principal Name: <input style="width: 95%;" type="text"/>	
Account Supervisor Principal Name: <input style="width: 95%;" type="text"/>	
Account Manager Principal Name: <input style="width: 95%;" type="text"/>	
Organization Code: <input style="width: 95%;" type="text"/>	
Sub-Fund Group Code: <input style="width: 95%;" type="text"/>	
Account Expiration Date: <input style="width: 95%;" type="text"/>	
Account Postal Code: <input style="width: 95%;" type="text"/>	
Account City Name: <input style="width: 95%;" type="text"/>	
Account State Code: <input style="width: 95%;" type="text"/>	
Account Street Address: <input style="width: 95%;" type="text"/>	
Continuation Chart Of Accounts Code: <input style="width: 95%;" type="text"/>	
Continuation Account Number: <input style="width: 95%;" type="text"/>	
Income Stream Chart Of Accounts Code: <input style="width: 95%;" type="text"/>	
Income Stream Account Number: <input style="width: 95%;" type="text"/>	
CFDA Number: <input style="width: 95%;" type="text"/>	
Higher Education Function Code: <input style="width: 95%;" type="text"/>	
Account Sufficient Funds Code: <input style="width: 95%;" type="text"/>	
TP Sufficient Funds Check: <input style="width: 95%;" type="text"/>	

Edit List of Accounts
▼ hide

New Account	
* Chart Code: <input style="width: 95%;" type="text"/>	Look
* Account Number: <input style="width: 95%;" type="text"/>	
Account Name: <input style="width: 95%;" type="text"/>	
<input type="button" value="add"/>	

Notes and Attachments (0)
▶ show

Ad Hoc Recipients
▶ show

Route Log
▶ show

Note

For more information about a specific global document, see the subsection for that e-doc.

Edit List of xxx Tab

The global documents include the **Edit List of xxx** (where xxx is an attribute name) tab which allows you to add the attributes you want to modify. This can be done by looking up attributes to include on your

document and using the **Look Up / Add Multiple xxx** lookup  or by adding the values manually one at a time. At least one item must be selected on the **Edit List of xxx** tab.

Note

For more information about a specific global document, see the subsection for that e-doc.

Note

It is important to note that *all global documents do not behave in exactly the same way*. For accounts and organization reversion, the global document can only *update* accounts and organization reversion rules. For object and sub-object codes, the global document allows you to *create new and update* codes. The Account Delegate Global document is unique in that it deactivates all existing delegation for accounts on the document and replaces it with the delegation on the document.

Account



The Account document is used to create new accounts or to edit or copy existing accounts. An account is used to identify a pool of funds assigned to a specific university organizational entity for a specific purpose. Accounts are the fundamental building blocks of Quali Financial Transactions. Financial Transactions are always associated with one or more accounts. Accounts and Objects are assigned budgets, and provide the financial framework for budgeting, balance inquiries, and encumbering funds for Purchase Orders, or paying vendors via Payment Requests.

An account has many different attributes associated with it that often determine how OLE allows you to use that account in transactions. It also has attributes associated with it that aid in reporting or drive special processes, such as indirect cost calculation.

The Account document comes with a global document option where you may make certain changes to a group of accounts at once. Key attributes for OLE Accounts are: Stewardship Requirement, Legacy Fund Code, Fund Group & Sub-Fund group. Each can be used in the future for queries, extracts and reporting as additional “sorts”. The feature of the Account Global document is explained in the section following the Account document.

The Account document has six account specific tabs: **Account Maintenance**, **Account Responsibility**, **Guidelines and Purpose**, **Account Description**, **Stewardship Requirements**, and **Legacy Fund Codes** tabs which group related attributes together.

Document Layout

Account ?	Doc Nbr: 3350	Status: INITIATED
	Initiator: ole-khuntley	Created: 10:32 AM 05/27/2013

expand all collapse all
* required field

Document Overview ▼ hide

Document Overview

* Description: <input style="width: 90%;" type="text"/>	Explanation: <input style="width: 95%;" type="text"/>
Organization Document Number: <input style="width: 90%;" type="text"/>	

Account Maintenance ▼ hide

New

* Chart Code: <input style="width: 80%;" type="text"/>
* Account Number: <input style="width: 80%;" type="text"/>
* Account Name: <input style="width: 95%;" type="text"/>
* Organization Code: <input style="width: 80%;" type="text"/>
Campus Code: <input style="width: 80%;" type="text"/>
* Account Effective Date: <input style="width: 80%;" type="text"/>
Account Expiration Date: <input style="width: 80%;" type="text"/>
Account Postal Code: <input style="width: 80%;" type="text"/>
Account City Name: <input style="width: 90%;" type="text"/>
Account State Code: <input style="width: 80%;" type="text"/>
Account Street Address: <input style="width: 95%;" type="text"/>
Account Off Campus Indicator: <input type="checkbox"/>
Closed?: <input type="checkbox"/>
Account Type Code: <input style="width: 80%;" type="text"/>
* Sub-Fund Group Code: <input style="width: 80%;" type="text"/>
Vendor For Deposit Account: <input style="width: 80%;" type="text"/>
* University Account Number: <input style="width: 80%;" type="text"/>
* Account Restricted Status Code: <input style="width: 80%;" type="text"/>
Account Restricted Status Date: <input style="width: 80%;" type="text"/>
Endowment Chart Of Accounts Code: <input style="width: 80%;" type="text"/>
Endowment Account Number: <input style="width: 80%;" type="text"/>

Account Responsibility ▼ hide

New

* Fiscal Officer Principal Name: <input style="width: 80%;" type="text"/>
Account Supervisor Principal Name: <input style="width: 80%;" type="text"/>
Account Manager Principal Name: <input style="width: 80%;" type="text"/>
Continuation Chart Of Accounts Code: <input style="width: 80%;" type="text"/>
Continuation Account Number: <input style="width: 80%;" type="text"/>
Income Stream Chart Of Accounts Code: <input style="width: 80%;" type="text"/>
Income Stream Account Number: <input style="width: 80%;" type="text"/>
Object Presence Control Indicator: <input type="checkbox"/>

Guidelines And Purpose ▼ hide

New

* Account Expense Guideline Text:	<input style="width: 95%; height: 40px;" type="text"/>
Account Income Guideline Text:	<input style="width: 95%; height: 40px;" type="text"/>
Account Purpose Text:	<input style="width: 95%; height: 40px;" type="text"/>



Account Description ▼ hide	
New	
Campus Description:	<input type="text"/>
Organization Description:	<input type="text"/>
Responsibility Center Description:	<input type="text"/>
Stewardship Requirements ▼ hide	
New Stewardship Requirement	
* Stewardship Type:	<input type="text"/> ▼ 🔍
Stewardship Note:	<input type="text"/>
<input type="button" value="add"/>	
Legacy Fund Codes ▼ hide	
New Legacy Fund Code	
Legacy FundCode:	<input type="text"/>
Legacy FundCode Note:	<input type="text"/>
<input type="button" value="add"/>	
Sufficient Funds Check ▼ hide	
New	
* Account Sufficient Funds Code:	<input type="text"/> ▼ 🔍
Transaction Processing Sufficient Funds Check:	<input type="checkbox"/>
* Encumbrance/Expense Method:	<input type="text"/> ▼
* Encumbrance/Expense Constraint Type:	<input type="text"/> ▼
* Encumbrance Amount:	<input type="text"/>
* Expense Amount:	<input type="text"/>
* Notification Type:	<input type="text"/> ▼
Notes and Attachments (0) ▶ show	
Ad Hoc Recipients ▶ show	
Route Log ▶ show	
<input type="button" value="submit"/> <input type="button" value="save"/> <input type="button" value="blanket approve"/> <input type="button" value="close"/> <input type="button" value="cancel"/>	





Account Maintenance Tab

The fields on this tab define the various account attributes which are used in the application of business rules for transactions using the account, reporting options, approval routing, etc.

Account Maintenance ▼ hide	
New	
* Chart Code:	<input type="text"/> 🔍
* Account Number:	<input type="text"/>
* Account Name:	<input type="text"/>
* Organization Code:	<input type="text"/> 🔍
Campus Code:	<input type="text"/> ▼ 🔍
* Account Effective Date:	02/11/2013 📅
Account Expiration Date:	<input type="text"/> 📅
Account Postal Code:	<input type="text"/> 🔍
Account City Name:	<input type="text"/>
Account State Code:	<input type="text"/> 🔍
Account Street Address:	<input type="text"/>
Account Off Campus Indicator:	<input type="checkbox"/>
Closed?:	<input type="checkbox"/>
Account Type Code:	<input type="text"/> ▼ 🔍
* Sub-Fund Group Code:	<input type="text"/> 🔍
Vendor for Deposit Account:	<input type="text"/> 🔍
* University Account Number:	<input type="text"/>
* Account Restricted Status Code:	<input type="text"/> ▼ 🔍
Account Restricted Status Date:	<input type="text"/> 📅
Endowment Chart Of Accounts Code:	<input type="text"/> ▼ 🔍
Endowment Account Number:	<input type="text"/> 🔍

Account Maintenance tab definition

Title	Description
Chart Code	Required. Enter the code or search for it from the Chart lookup  . Uniquely identifies a single chart of accounts. The COA is the set of controlling tables that define financial information, such as the codes and coding structures within Quali Financial System (OLE), including attributes like Accounts, Organizations, and Object Codes. The COA module exists primarily to support and validate entries into the General Ledger (G/L).
Account Number	Required. Enter the unique number to identify a pool of funds assigned to a specific institution entity for a specific function. Note You may restrict the account prefix by the use of the parameter. For example, you may configure to reject account numbers beginning with '3' or with '00'. Identifier for a pool of funds assigned to a specific university entity for a specific function.
Account Name	Required. Enter the familiar title of a specific account
Organization Code	Required. Enter the number for the owner of the account, or search for it from the Organization lookup  . Represents a unique identifier assigned to units within an institution.
Campus Code	Required. Select the physical campus on which the account is located from the Campus list, or search for it from the lookup  . Represents the physical location of the account.
Account Effective Date	Required. Enter the date when the account became effective.

	<p>Note</p> <p>An account may be used on financial transactions before its effective date.</p>
Account Expiration Date	<p>Optional. Enter the date when the account expires. Business rules on transactions may prevent the use of expired accounts, or provide warnings when an expired account is being used.</p> <p>Must be equal to or greater than the current date and cannot be before the Account Effective Date. If it is not blank, the continuation Chart of Accounts code and continuation account number are required.</p>
Account Postal Code	<p>Required. Enter the postal code assigned by the US Postal Service for the city where the account is managed, or search for it from the Postal Code lookup .</p>
Account City Name	<p>Required. Enter the city where the account is managed.</p>
Account State Code	<p>Required. Enter the code for the state where the account is managed, or search for it from the State lookup .</p>
Account Street Address	<p>Required. Enter the street address where the account is managed.</p>
Account Off Campus Indicator	<p>Optional. Select the check box if the account activities occur off-campus; clear the check box if they do not.</p>
Closed?	<p>Optional. Select the check box if the account is closed; clear the check box if it is open.</p> <p>Closing an account is more permanent than expiring - no transactions can use a closed account and a closed account can only be re-opened by a system supervisor.</p>
Account Type Code	<p>Required. Select from the Account Type list or search for it from the lookup . Examples used to categorize accounts for reporting purposes might include 'Fee Remissions Accounts' or 'Equipment Accounts.'</p> <p>A code that categorizes or groups accounts for reporting purposes.</p>
Sub-Fund Group Code	<p>Required. Enter the code which relates an account to a fund, or search for it from the Sub-Fund Group lookup . Examples are continuing education accounts, scholarships and fellowships, and general funds.</p> <p>A designation of an account specific to fund accounting.</p>
Vendor for Deposit Account	<p>Enter the vendor associated with the Deposit Account, or search for it from the Vendor lookup . This field is NOT allowed unless Sub Fund Group selected equals "Clearing/Revolving" or "Deposit", and then it is required.</p>
University Account #	<p>University Account Number associated with the Library Account. Ensures financial data is matched correctly to the University Account in the enterprise-wide financial system.</p>
Account Restricted Status Code	<p>Required. Select the account restricted status code from the Account Restricted Status list. This code indicates whether funds in the account are:</p> <p>T = Temporarily restricted R = Restricted U = Unrestricted</p> <p>If it is 'T,' then an account restricted status date is required. If the sub-fund associated with the account has a restricted status code, then that number pre-fills the field, in which case it is not editable. If the code on the sub-fund is blank, the Restricted Status Code field on the Account document must be completed.</p>
Account Restricted Status Date	<p>Optional. Enter the date if the accounts restricted status code above is 'T.' This date signifies when the funds are targeted to become unrestricted.</p> <p>If the Account Restricted Status Code is T (Temporarily Restricted), then this field becomes required and the date signifies when the funds are targeted to become unrestricted.</p>
Endowment Chart of Accounts Code	<p>Optional. Select the Chart of Account code from the Chart list for the account designated to receive income generated from an endowment</p>







	account or for the guarantee account for an underwrite for Contracts and Grants accounts.
Endowment Account Number	Optional. Enter the account designated to receive income generated from an endowment account or the guarantee account for an underwrite for Contracts and Grants accounts, or search for it from the Account lookup 

Account Responsibility Tab



The fields on this tab define the individuals responsible for the account as well as continuation account information and Sufficient Funds parameters.





Account Responsibility ▼ hide

New

* Fiscal Officer Principal Name:	<input type="text"/> 
Account Supervisor Principal Name:	<input type="text"/> 
Account Manager Principal Name:	<input type="text"/> 
Continuation Chart Of Accounts Code:	<input type="text"/> ▼ 
Continuation Account Number:	<input type="text"/> 
Income Stream Chart Of Accounts Code:	<input type="text"/> ▼ 
Income Stream Account Number:	<input type="text"/> 
Object Presence Control Indicator:	<input type="checkbox"/>

Account Responsibility tab definition

Title	Description
Fiscal Officer Principle Name	<p>Required. Enter the name of the fiscal officer, or search for it from the  lookup.</p> <p>The Fiscal Officer is a person who is trained and hired for the purpose of providing fiscal, policy, and internal control management of all funds in a unit. They are responsible for ensuring that processes and related controls have been established to achieve the mission and objectives of their organization(s).</p>
Account Supervisor Principle Name	<p>Optional. Enter the name of the account supervisor, or search for it from the  lookup. The supervisor oversees the management of the account at a higher-level than the fiscal officer, but rarely receives any direct requests for action from OLE. The account supervisor cannot be the same as the fiscal officer or the account manager.</p> <p>The Account Supervisor will be the leader of the organization in which the account resides. In an academic unit this would probably be the Dean, in an administrative unit it would be the Vice President.</p>
Account Manager Principle Name	<p>Optional. Enter the name of the account manager, or search for it from the  lookup. The account manager has the responsibility for ensuring that funds are spent and managed according to the goals, objectives and mission of the organization, to ensure that the funds are being spent according to a budgeted plan and that the allocation of expenditures is appropriate to the function identified for the account.</p> <p>The Account Manager is the person who through their actions, their position, or the budgeting process of the Dean or Vice President has direct responsibility for how funds are spent and managed. Examples would be a principal investigator who received a grant or contract, an</p>

	academic person who received internal research funds from the Dean, or a Director of a non-academic department.
Continuation Chart of Accounts Code	Optional unless the account has an expiration date, in which case it is required. Enter the chart code for the continuation account, or search for it from the Chart lookup  . The field is required if the account has an expiration date.
Continuation Account Number	Optional unless the account has an expiration date, in which case it is required. Enter the account that accepts transactions which are being processed on the account after the account expiration date, or search for it from the Account lookup  .
Income Stream Chart of Accounts Code	Optional. Select the Chart of Accounts for the income stream account from the Chart list, or search for it from the Chart lookup  . Parameters control when the income stream chart of accounts code and income stream account number are required.
Income Stream Account Number	Optional. Enter the account which has been designated to receive any offset entries from the account in order to balance responsibility center activity from the Account list or search for it from the lookup  . The account designated to receive general fund income as part of the budget process for institutional funds, or the account designated to receive income from the sponsoring agency on contract and grant funds. When Budget Adjustments that involve accounts with different income stream accounts are made, OLE can be configured to create an automated Transfer of Funds transaction to properly adjust cash between those income stream accounts.
Object Presence Control Indicator	Optional. Select the check box to indicate that the account uses object presence control. Clear the check box if it does not. Object presence control requires that an object code be budgeted for the account before it can be used on an actual or encumbrance transaction. If checked, requires that an Object Code be budgeted for the account before it can be used on an actual or encumbrance transaction.

Guidelines and Purpose Tab

The fields in the **Guidelines and Purpose** tab collect text description that provide details relating to the type of expenses that should be charged to the account, the source of its income, and the account's overall purpose.

Guidelines And Purpose ▼ hide

New

* Account Expense Guideline Text:	<input style="width: 95%; height: 25px;" type="text"/>
* Account Income Guideline Text:	<input style="width: 95%; height: 25px;" type="text"/>
* Account Purpose Text:	<input style="width: 95%; height: 25px;" type="text"/>

Guidelines and Purpose tab definition

Title	Description
Account Expense Guideline Text	Required unless the account expiration date is before the current date. Enter the text describing the type of expenditures that take place in the account. It should also explicitly state those expenditures that are unallowable in the account.

Account Income Guideline Text	Required unless the account expiration date is before the current date. Enter the text describing the types of income (source of funds) that take place in the account. It should also explicitly state those revenues that are unallowable in the account.
Account Purpose Text	Required. Enter the text describing the overall purpose of the account and the function it supports.

Account Description Tab

The **Account Description** tab contains optional information relating to the physical location of the account.

Account Description tab definition

Title	Description
Campus Description	Optional. Enter additional campus description if desired on the account.
Organization Description	Optional. Enter additional organization description if desired on the account.
Responsibility Center Description	Optional. Enter responsibility center description if desired on the account.

Stewardship Requirements Tab

Stewardship Requirements have been added as metadata to be used in future workflows and routing (think: book plating, donors, etc.) This tab is repeatable- do not forget to use the **add** button to commit new Stewardship Requirements to the Account.

Account Stewardship Requirements tab description

Title	Description
Stewardship Type	Identify the type of stewardship.
Stewardship Note	Note related to the stewardship requirement.

Legacy Fund Codes Tab

Legacy Fund Codes are added to assist libraries with migrating from legacy systems and combined fund code strings (which had fiscal year, account, and object information). This tab is repeatable- do not forget to use the button to commit new Legacy Fund Codes to the Account.

Legacy Fund Codes tab description

<i>Title</i>	<i>Description</i>
Legacy Fund Code	Uniquely identifies legacy systems' fund codes
Legacy Fund Code Note	Note related to the legacy fund code

Sufficient Funds Check tab

Sufficient funds checking is an option that can be used to stop the processing of e-doc transactions when an account does not have a balance large enough to cover expense transactions.

Sufficient funds checking can be established on an account-by-account basis. If the **Transaction Process Sufficient Funds Check** option on an account is checked and the **Account Sufficient Funds Code** is set to a value other than 'N' (no checking), then the account is checked for sufficient funds by OLE.

Sufficient Fund Check (SFC) operates differently on encumbrances vs. expenditures:

Encumbrances check against Free Balances (Budget - invoices (liabilities) [pending included] - expenditures [pending included] - encumbrances [pending included]), occurs when encumbrances is pending (when requisition created/accts and costs assigned)

Expenditures check against Cash Balance (Budget - expenditures [pending included]) - when Payment Request created (pending).

The sufficientFundsAccountUpdateJob, which can be scheduled or run on demand, evaluates the pending ledger entries to determine whether or not they affect sufficient funds.

Note

For information about how to run this batch job, see **Schedule** in the *Guide to OLE System Administration Functions* .

Sufficient Funds Check tab description

Title	Description
Account Sufficient Funds Code	Required. Select the code that indicates what level the account is going to be checked for sufficient funds in the transaction processing environment from the Account Sufficient Funds list. The choices are: A = Account C = Consolidation L = Level O = Object Code H = Cash N = No Checking
Transaction Processing Sufficient Funds Check	Optional. Select the check box if sufficient funds check should be performed on the account.
Encumbrance / Expense Method	Identifies the type of encumbrance or expense, i.e., "over" or "under".
Encumber / Expense Constraint Type	Coded selection choice of # (for Amount) or % (for Percentage).
Encumbrance Amount	Enter a value to be checked when encumbering the account on purchase orders.
Expense Amount	Enter a value to be checked when paying the account on payment requests.
Notification Type	When the sufficient fund amount has been reached, you may select what will occur: <ul style="list-style-type: none"> • Block user: Transaction cannot go through • Warning: User gets warning message: "Account #xxxxx, has SFC (type) checking, and (accounting line) exceeds available balance thresholds." • Routing: Route to the identified Fiscal Officer on Account for Approval. • Notifications: Transactions occur, but Fiscal Officer is notified of threshold being exceeded (to take corrective action, moving budgets etc.).

Process Overview

Business Rules

The Employee Type for the Financial-AQ4, Financial-AQ5, Accounting-AQ4 Fiscal Officer, Account Supervisor, and Account Manager must be 'P (Professional)' and the Employee Status must be 'A (Active).

The following rules apply to closing an account:

- You must select an account active indicator: closed.
- Account expiration date must be the current date or earlier
- A continuation account number must be provided.
- Only fully-approved Accounts (like other OLE documents) will display in Account Lookup inquiries or future Available balance inquiries.
- The account must meet all the following criteria:
 - expires on or before the current date
 - has no budget balance
 - has no pending ledger entries
 - has no open encumbrances
 - has no asset, liability, or fund balances other than the fund balance object code defined for this account's chart and the process of closing income and expense into fund balance must take the fund balance to zero.
- Only a system supervisor user can reopen a closed account.

Routing

The document routes to the fiscal officer for the account indicated on the document. If the document edits an existing account and includes a change to the value of the **Fiscal Officer** field, the document routes first to the current fiscal officer and then to the newly designated fiscal officer.

- The document routes to the Org Reviewer based on the organization assigned to the account.
- The document routes to the Chart Manager based on the chart assigned to the account.
- Accounts route to the University Chart Manager for final approval.
- As an OLE User, the Account Supervisor receives an FYI copy of the document.

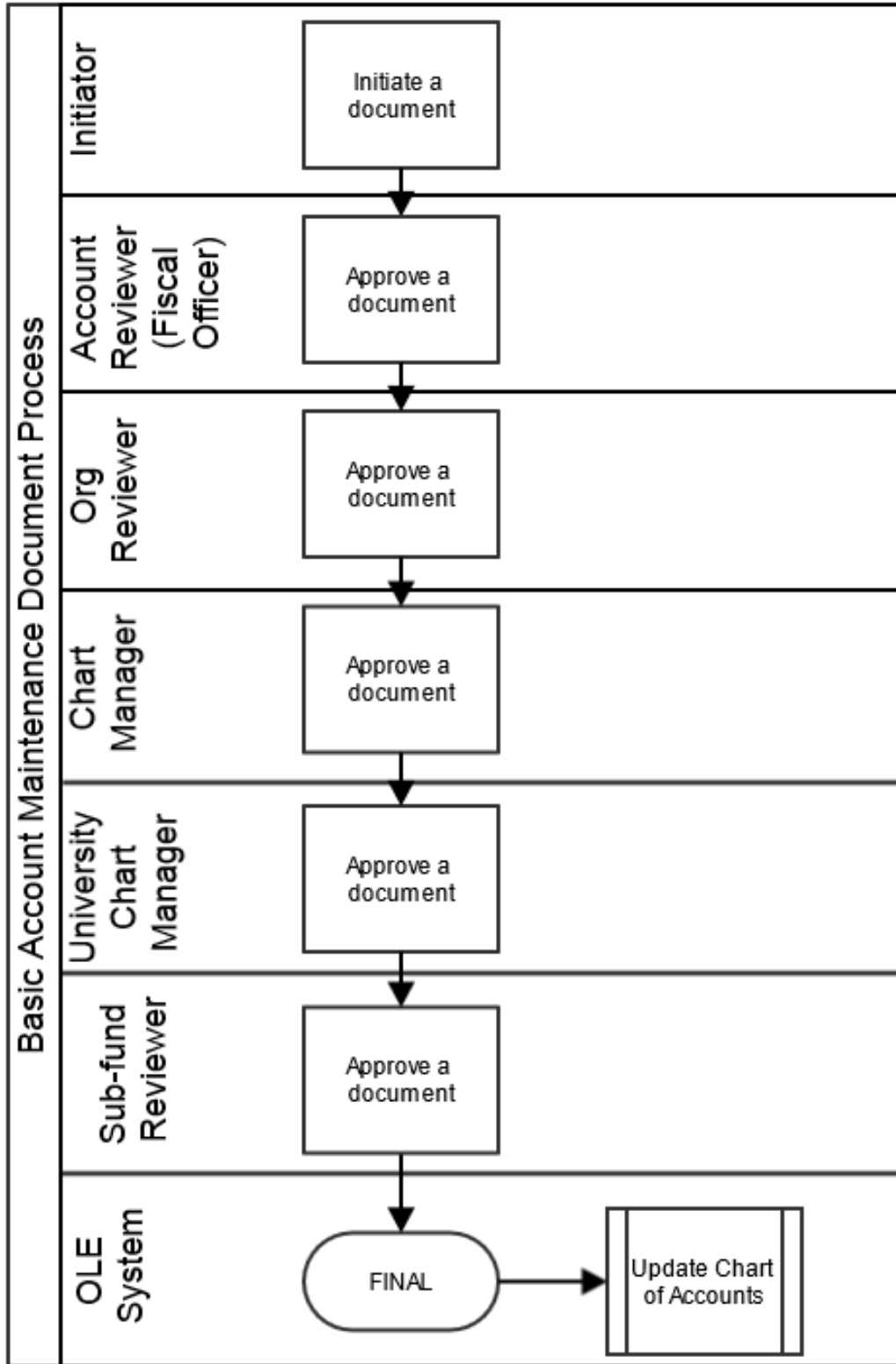

Account Global



Note

For general information about accessing and working with global documents, see [Global COA E-Docs](#).

The Account Global document is used to assign identical attributes to multiple accounts on a single document. This could be used at initial implementations, or when needing to apply attributes for future reporting and extract. The same rules and options apply to Account Global documents as to Account e-docs, but with some restrictions on fields, and more routing/workflow.

Document Layout

The Account Global document contains the **Global Account Maintenance** screen and **Edit List of Accounts** tab.

Account Global		Doc Nbr:
		Initiator:

Document Overview ▼ hide

Document Overview

* Description: <input type="text"/>	Explanation: <input type="text"/>
Organization Document Number: <input type="text"/>	

Global Account Maintenance ▼ hide

New

Fiscal Officer Principal Name: <input type="text"/>
Account Supervisor Principal Name: <input type="text"/>
Account Manager Principal Name: <input type="text"/>
Organization Code: <input type="text"/>
Sub-Fund Group Code: <input type="text"/>
Account Expiration Date: <input type="text"/>
Account Postal Code: <input type="text"/>
Account City Name: <input type="text"/>
Account State Code: <input type="text"/>
Account Street Address: <input type="text"/>
Continuation Chart Of Accounts Code: <input type="text"/> ▼
Continuation Account Number: <input type="text"/>
Income Stream Chart Of Accounts Code: <input type="text"/> ▼
Income Stream Account Number: <input type="text"/>
Account Sufficient Funds Code: <input type="text"/> ▼
Transaction Processing Sufficient Funds Check: <input type="text"/> ▼

Edit List of Accounts ▼ hide

New Account

* Chart Code: <input type="text"/> ▼
* Account Number: <input type="text"/>
Account Name: <input type="text"/>













Notes and Attachments (0)

Ad Hoc Recipients

Route Log

Global Account Maintenance Tab



The **Global Account Maintenance** tab works the same as the **Edit Account Maintenance** tab of the Account document except that it contains only the fields that can be modified from this tab. There are no required fields in this tab. Instead, you only need to complete the fields that you want to update on the selected accounts. If an account attribute is to remain as is, leave that field blank.

Global Account Maintenance ▼ hide	
New	
Fiscal Officer Principal Name:	<input type="text"/> 
Account Supervisor Principal Name:	<input type="text"/> 
Account Manager Principal Name:	<input type="text"/> 
Organization Code:	<input type="text"/> 
Sub-Fund Group Code:	<input type="text"/> 
Account Expiration Date:	<input type="text"/> 
Account Postal Code:	<input type="text"/> 
Account City Name:	<input type="text"/>
Account State Code:	<input type="text"/> 
Account Street Address:	<input type="text"/>
Continuation Chart Of Accounts Code:	<input type="text"/> ▼ 
Continuation Account Number:	<input type="text"/> 
Income Stream Chart Of Accounts Code:	<input type="text"/> ▼ 
Income Stream Account Number:	<input type="text"/> 
Account Sufficient Funds Code:	<input type="text"/> ▼ 
Transaction Processing Sufficient Funds Check:	<input type="text"/> ▼

Note

For more information about how to complete the **Global Account Maintenance** tab, see [Account](#).

Edit List of Accounts Tab

There are two ways to populate the accounts that you want to update globally in the **Edit List of Accounts** tab. One is by manually entering or selecting one object code at a time from the normal **Account** lookup , the other is by using a special multiple value lookup called the **Look Up / Add Multiple Account Lines**  to return multiple values.

Note

For more information about the two types of lookup, see [Field Lookup](#) and [Multiple Value Lookup](#) on the *OLE E-Doc Fundamentals* wiki page.

Process Overview

Business Rules

The Account Global document is subject to the same business rules as the Account document. In addition, at least one account must be selected on the **Edit List of Accounts** tab.

Note

For the information about the Account document business rules, see [Account](#).

Routing

The Account Global document routes to the Chart Manager for every chart represented in the accounts being modified, and then to the University Chart Manager.

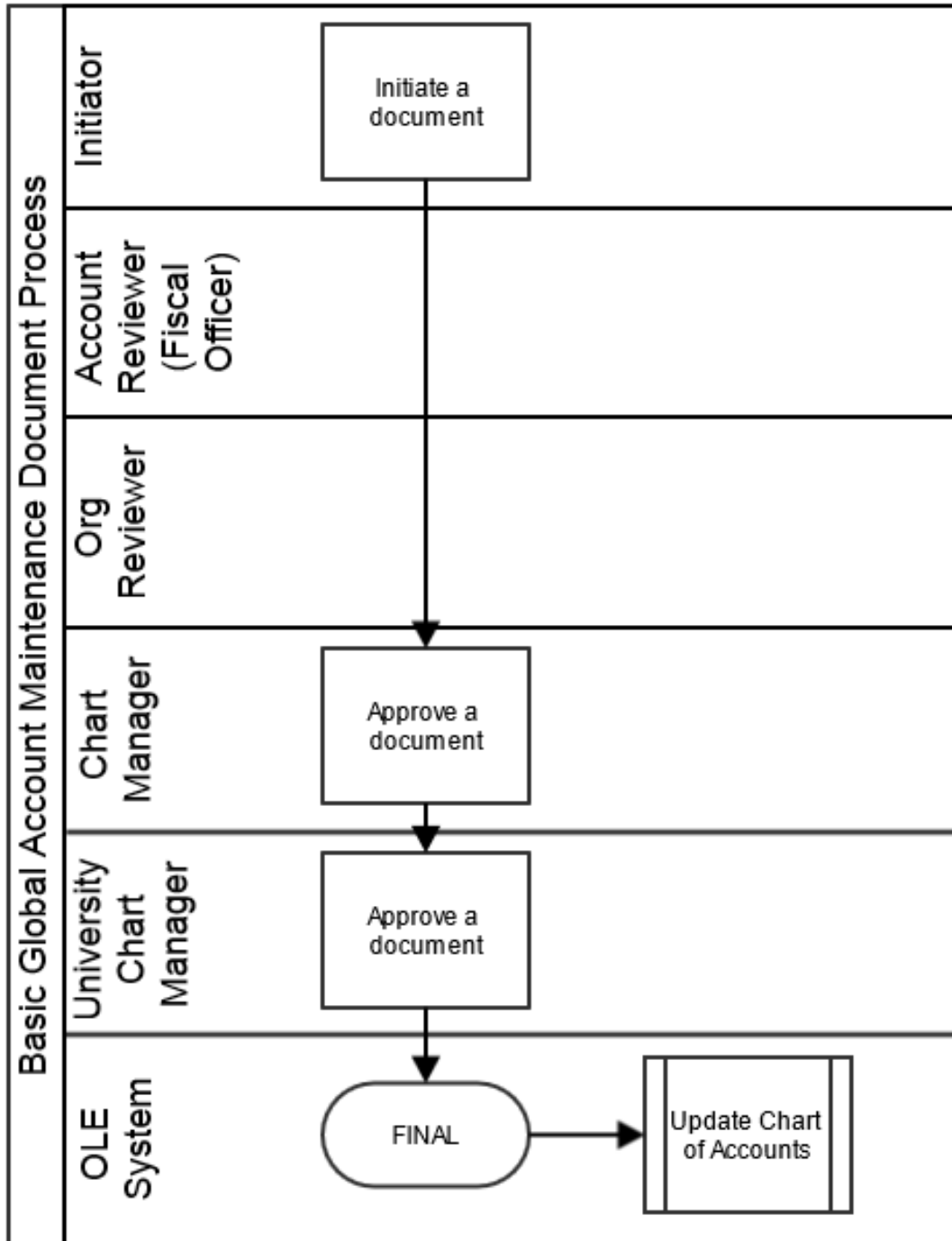

Initiating an Account Global Document

Using Look Up / Add Multiple Account Lines

1. Complete the **Global Account Maintenance** tab.
2. To add multiple accounts to the **Edit List of Accounts** tab, click the **Look Up / Add Multiple Account Lines** lookup .



3. Enter the desired search criteria to search for the accounts you want to include and click .

4. After the result is returned, select check boxes to make your account selection and click .

The selected accounts are returned to the **Edit List of Accounts** tab.

5. Click .

Adding One Account at a Time

6. Complete the **Global Account Maintenance** tab.
7. To add one account at a time, enter the values or use the **Account** lookup .
8. Enter the desired search criteria to search for the accounts you want to include and then click .

Note

For information about how to retrieve a document, see [Using Doc Search to Find a Document](#) on the *OLE E-Doc Fundamentals* wiki page.

9. Click  to add the account to the list.

Object Code

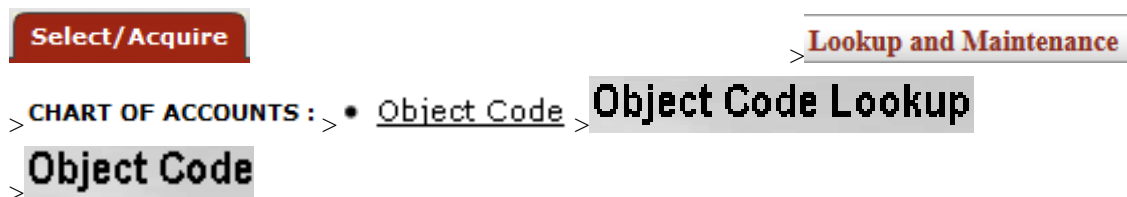

The Object Code document is used to establish new object codes or to copy or edit existing object codes. Object codes are a four character codes that represent all income, expense, asset, liability and fund balance

classifications that are assigned to transactions and help identify the nature of the transaction. Examples of object codes might include travel expenditures, student fee income, accounts receivable, and invoices payable. Object codes are specific to a chart and a fiscal year and contain several attributes throughout OLE for financial reporting at the detail and consolidated levels.

Use of Object Codes in OLE sample data is based on typical reporting or budgeting requirements—monograph, serial, electronic.

All Object Codes must Report to an Object code, have an Object Type Code, Level Code, and Object Sub-Type Code. In OLE, we are using “EE” Object code to represent “Expenditure not Expense”. The Object Level code is used to maintain an attribute of the object code that is used to group similar object codes into categories for reporting. Object sub-types are used in financial rules and OLE Parameters to limit how and where an object code may be used (types of transactions, etc.).

The Object Code document comes with a global document option where you can create a group of new object codes or update the existing object codes all at once.

Note

For more information about the global document see [Object Code Global](#).

From the Lookup screen, enter any search criteria, such as Fiscal Year= 2012, Chart= BL, and Object Code = 71* to view existing sample Library Object codes, to **edit** or **copy** them, or **create new**.

Document Layout

The Object Code document includes the **Edit Object Code** tab.

Object Code ?	Doc Nbr: 3951	Status:
	Initiator: ole-khuntley	Created:

expa

▼ hide

Document Overview

* Description: <input style="width: 95%;" type="text"/>	Explanation: <input style="width: 95%; height: 40px;" type="text"/>
Organization Document Number: <input style="width: 60%;" type="text"/>	

▼ hide

Edit Object Code

Old	New
Fiscal Year: 2013	Fiscal Year: 2013
Chart Code: BA - BLOOMINGTON AUX	Chart Code: BA - BLOOMINGTON A
Object Code: 0110	Object Code: 0110
Object Code Name: BALANCE FORWARD	* Object Code Name: <input style="width: 95%;" type="text" value="BALANCE FORWARD"/>
Object Code Short Name: BAL FORWARD	* Object Code Short Name: <input style="width: 95%;" type="text" value="BAL FORWAR"/>
Reports to Chart Code: BL - BLOOMINGTON	Reports to Chart Code: BL - BLOOMINGTON
Reports To Object Code: 0110	* Reports To Object Code: <input style="width: 95%;" type="text" value="0110"/> 🔍
Object Type Code: IN	* Object Type Code: <input style="width: 95%;" type="text" value="IN"/> 🔍
Level Code: BCAS	* Level Code: <input style="width: 95%;" type="text" value="BCAS"/> 🔍
Object Sub-Type Code: BU	* Object Sub-Type Code: <input style="width: 95%;" type="text" value="BU"/> 🔍
Active Indicator: Yes	Active Indicator: <input checked="" type="checkbox"/>

Notes and Attachments (0) ▶ show





Ad Hoc Recipients ▶ show

Route Log ▶ show

Edit Object Code Tab

Edit Object Code ▼ hide	
Old	New
Fiscal Year: 2013	Fiscal Year: 2013
Chart Code: BA - BLOOMINGTON AUX	Chart Code: BA - BLOOMINGTON AUX
Object Code: 0110	Object Code: 0110
Object Code Name: BALANCE FORWARD	* Object Code Name: BALANCE FORWARD
Object Code Short Name: BAL FORWARD	* Object Code Short Name: BAL FORWARD
Reports to Chart Code: BL - BLOOMINGTON	Reports to Chart Code: BL - BLOOMINGTON
Reports To Object Code: 0110	* Reports To Object Code: 0110
Object Type Code: IN	* Object Type Code: IN
Level Code: BCAS	* Level Code: BCAS
Object Sub-Type Code: BU	* Object Sub-Type Code: BU
Active Indicator: Yes	Active Indicator: <input checked="" type="checkbox"/>

Edit Object Code tab definition

Title	Description
Fiscal Year	<p>Required. Enter the fiscal year of the object code or search for it from the Fiscal Year lookup .</p> <p>Note</p> <p>OLE is set up so the Object Code table is based on fiscal year therefore each year can have a different set of object codes.</p>
Chart Code	<p>Required. From the Chart list select the chart to which the object code belongs, or search for it from the lookup .</p>
Object Code	<p>Required. Enter the code to identify the object code which must be unique within the chart and fiscal year to which it belongs.</p>
Object Code Name	<p>Required. Enter the long descriptive name of the object code which appears on the Accounting Lines tab in financial documents as well as in searches and reports.</p>
Object Code Short Name	<p>Required. Enter the shortened version of the object code name for use in reporting where space is limited.</p>
Reports to Chart Code	<p>Display-only. The value automatically defaults to the Reports to Chart of Accounts Code value associated with the Reports to Object Code's Chart Code value once it is entered.</p>
Reports to Object Code	<p>Required. Enter the object code that the object code reports to in the next higher chart, or search for it from the Object Code lookup . For example, the object code for book sales in an auxiliary chart might report to the object code for sales and services in the campus chart</p>
Object Type Code	<p>Required. Enter the code or search for it from the Object Type lookup . This is used to identify an object code as income, expense, asset, liability or fund balance. Multiple values exist for income and expense to support GL functionality.</p>
Level Code	<p>Required. Enter the code or search for it from the Level lookup . This is the summary code for a given range of detailed object code classifications and identifies the level to which the object code belongs.</p>

Object Sub-Type Code	Required. Enter the code or search for it from the Object Sub-Type lookup  . This is the designation assigned to similar groups of object codes. Sub-types are often leveraged in OLE to apply business rules or to help with reporting.
Active Indicator	Optional. Select the check box if the object code is active and can be used on financial documents. Clear the check box if it is inactive.

Process Overview

Business Rules

- If the **Reports to Chart Code** value is not the highest chart level, the reports to object code, fiscal year, and chart code combination must exist in the Object Code Table.
- If the **Reports to Chart Code** value is at the highest level, then the object code must report to itself as an additional rule.

Note

Institutional Reporting: OLE provides for various fields available for institutional reporting. You can, for example, define a top level chart that consolidates activity for reporting purpose. After the top level chart is defined, the Statement of Net Assets and Statement of Revenues, Expenses and Changes in Net Assets can be designed, using 'Reports To' chart and object code and the sub-totals by the object code levels and consolidations on the top chart. Or, you may design responsibility center reports using the organization roll-up of accounts. For more information about the capabilities of the organization within the Chart of Accounts, refer to [Organization](#).

Routing

The Object Code document routes to the Chart Manager for the chart associated with the object code followed by routing to the University Chart Manager.

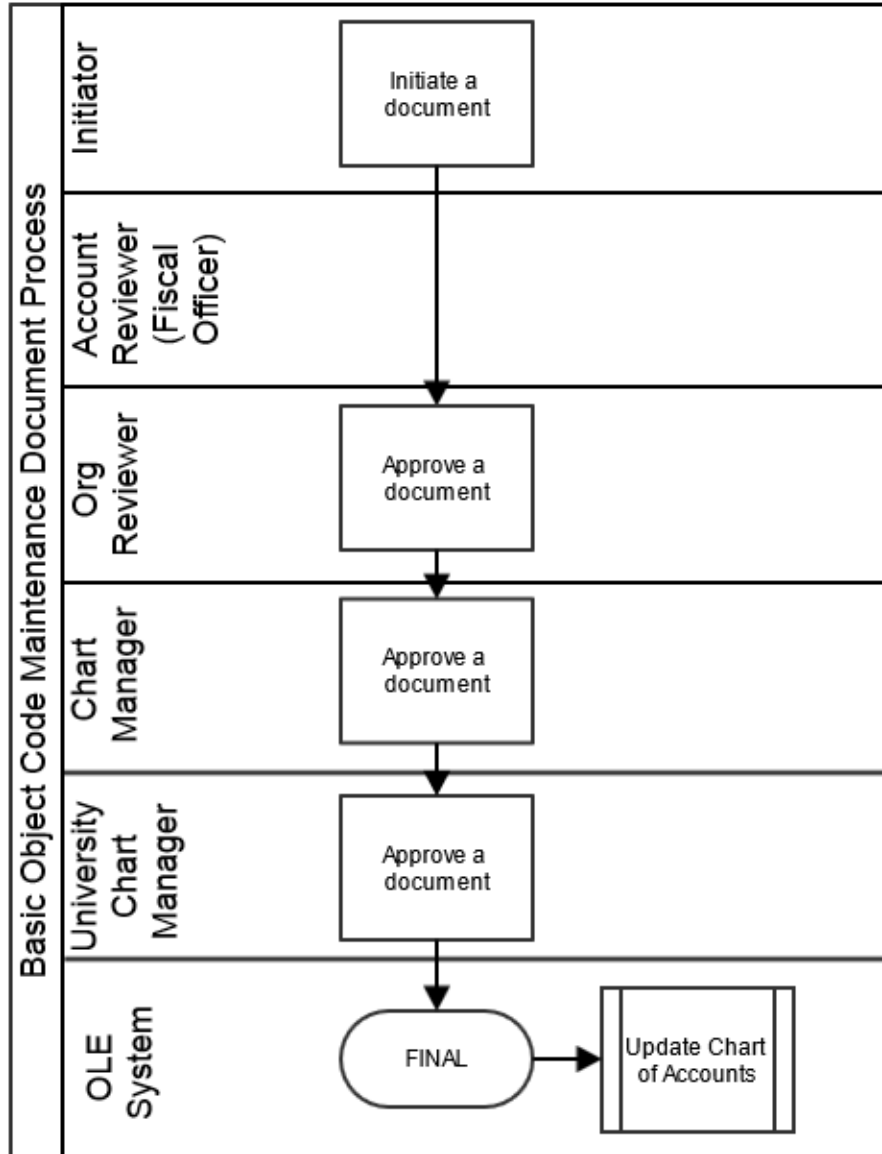

Object Code Global

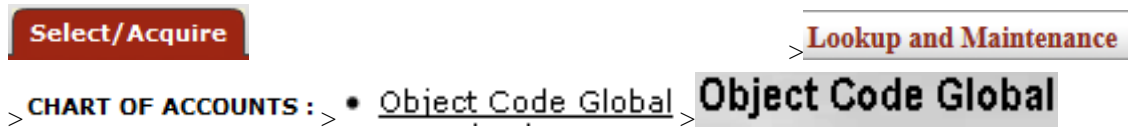

Note

For general information about accessing and working with global documents, see [Global COA E-Docs](#).

The object code global document is used to assign identical attributes to the same object code across multiple charts on a single document. The document can be initiated only by members of the OLE-SELECT Accounting-AQ4 role.

Document Layout

The Object Code Global document has two unique tabs: **Global Object Code Maintenance** and **Edit Multiple Year and Chart** tabs.

Object Code Global	Backdoor Id ole-lmeraz is in use		Doc Nbr: 3952	Status: INIT
			Initiator: ole-lmeraz	Created: 01:4

[expand all](#)

Document Overview ▼ hide

Document Overview

* Description:	<input type="text"/>	Explanation:	<input style="width: 100%; height: 100%;" type="text"/>
Organization Document Number:	<input type="text"/>		

Global Object Code Maintenance ▼ hide

New

* Object Code:	<input type="text"/>
* Object Code Name:	<input type="text"/>
* Object Code Short Name:	<input type="text"/>
* Reports To Object Code:	<input type="text"/>
* Object Type Code:	<input type="text"/>
* Level Code:	<input type="text"/>
* Object Sub-Type Code:	<input type="text"/>
Active Indicator:	<input checked="" type="checkbox"/>

Edit Multiple Year and Chart ▼ hide

New Year and Chart [Look Up/Add Multiple Char](#)

Fiscal Year:	<input type="text" value="2013"/>
Chart Code:	<input type="text"/>

Notes and Attachments (0) ▶ show

Ad Hoc Recipients ▶ show

Route Log ▶ show

Global Object Code Maintenance Tab

The **Global Object Code Maintenance** tab works the same as the **Edit Object Code** tab of the Object Code document and it contains all the attributes that are not specific to a year or chart that can be modified on this document. The required fields on the Global Object Code document are the same as on the Object Code document. Global object can both create new and update existing records. If you are changing certain attributes using this document and the other attributes are to remain as is, leave the field blank.

Global Object Code Maintenance		hide
New		
* Object Code:	<input type="text"/>	
* Object Code Name:	<input type="text"/>	
* Object Code Short Name:	<input type="text"/>	
* Reports To Object Code:	<input type="text"/>	
* Object Type Code:	<input type="text"/>	
* Level Code:	<input type="text"/>	
* Object Sub-Type Code:	<input type="text"/>	
Active Indicator:	<input checked="" type="checkbox"/>	

Note

For more information about how to complete the **Global Object Code Maintenance** tab, see [Object Code](#).

Edit Multiple Year and Chart Tab

There are two ways to populate the object codes that you want to update globally in the **Edit Multiple Year and Chart** tab. One is by manually entering or selecting one object code at a time from the normal Object Code lookup , the other is by using a special multiple value lookup called the **Look Up / Add Multiple Object Code Lines** to return multiple values.

Edit Multiple Year and Chart		hide
New Year and Chart		Look Up/Add Multiple Chart Lines
Fiscal Year:	<input type="text" value="2013"/>	
Chart Code:	<input type="text"/>	
<input type="button" value="add"/>		

Process Overview

Business Rules

The Global Object Code document is subject to the same business rules as the Object Code document. In addition, at least one account must be selected on the **Edit Multiple Year and Chart** tab.

Routing

- Only members of the OLE-SELECT Accounting-AQ4 role may initiate the document.
- The Global Object Code document routes to the Chart Manager for every Chart represented in the accounts being modified, and then to the University Chart Manager.

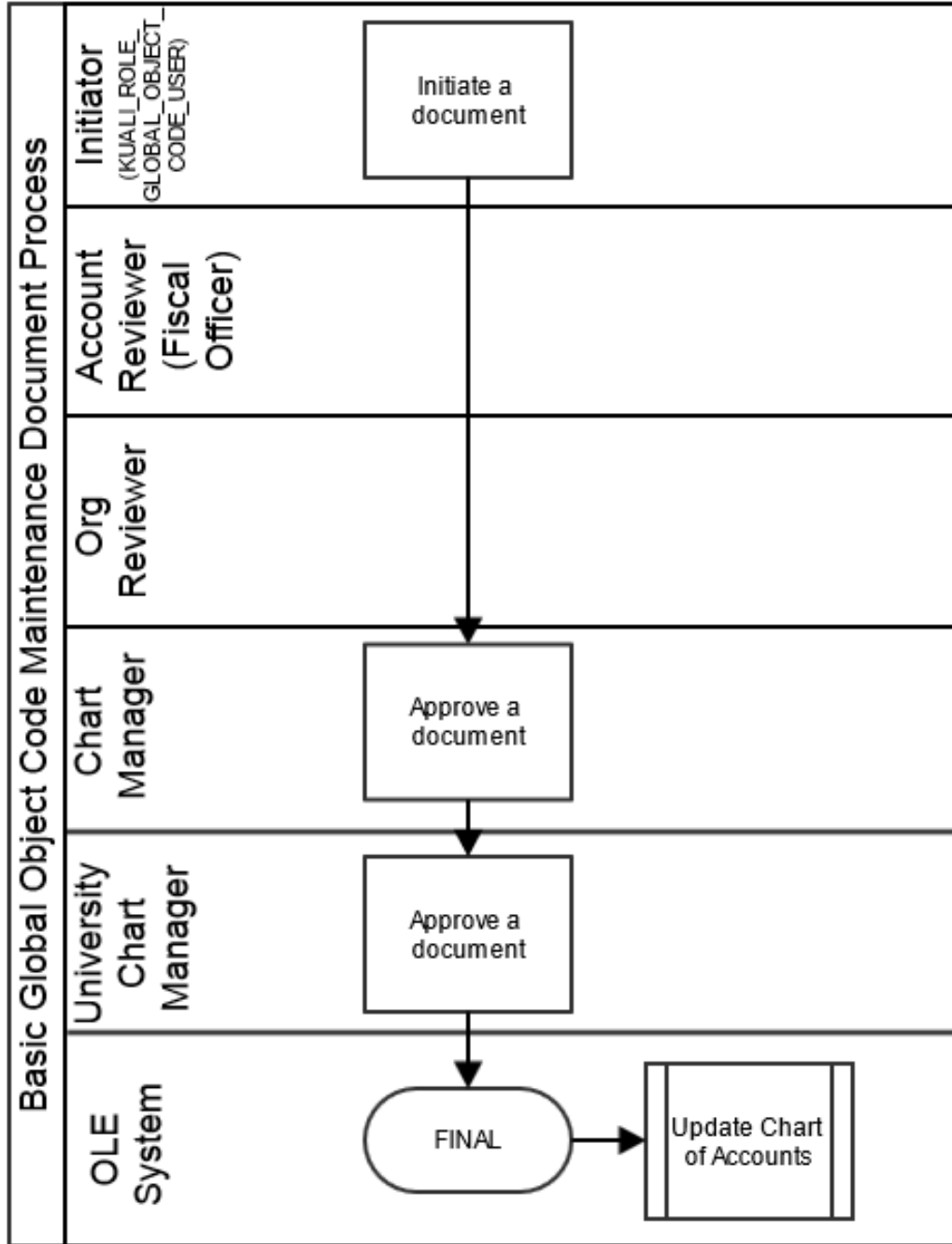

Initiating a Global Object Code document

Using Look Up / Add Multiple Object Code Lines

10. Complete the **Global Object Code** document. To add multiple object codes to the **Edit Multiple Year** and **Chart** tab, click the **Look Up / Add Multiple Object Code Lines** lookup .

11. Enter the desired search criteria to search for the object codes you want to include and click



12. After the result is returned, select check boxes to make your object code selection and click



13. Click .

Adding One Object Code at a Time

14. Complete the **Global Object Code** document. To add one object code at a time, enter the values or use the **Object Code** lookup .

15. Search for an object code and click the link associated with the object code you want to select.

Note

For information about field lookup and multiple value lookup, see [Field Lookup](#) and [Multiple Value Lookup](#) on the *OLE E-Doc Fundamentals* wiki page.

16. Click to add the object code to the list.

17. Click .

Organization

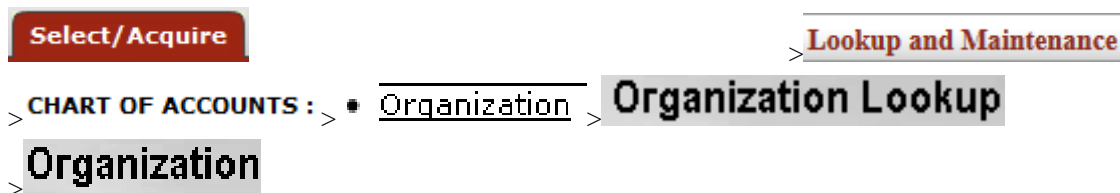

The Organization document defines the entities representing units at many different levels within the institution (for example, a department, responsibility center, campus). Organizations inside OLE can be used to denote Fiscal responsibility, and may be fiscal or physical organizations. There can be related organizations in a hierarchy under a single Chart. Accounts and objects belong to a single chart or organization. Organizations could be a specific library building, a department that has a budget, or by subject, depending on how adopting libraries wish to use Organizations for identifying structures, and then later use Object Codes for reporting on “like” materials or allocations.

The document collects important identifying information about an Organization and defines its place in the organization hierarchy. Organization is an important part of the Chart of Accounts and the organization hierarchy is frequently leveraged by OLE for use in Workflow and reporting.

Organizations are required in setting up accounts and objects

See list in [Appendix](#) of related library sample Organizations, such as LACQ- Library Acquisitions, or SOC- Sociology (each of these has related CoA structures and budgets), or **create new**.





To **edit** or **copy** an existing Organization, simply click on that option. Please do NOT change “Chart” code on existing library sample organizations, but users can edit miscellaneous OLE sample organizations not listed in this document.





Document Layout

The Organization document includes the **Edit Organization Code** tab.

Edit Organization Code ▼ hide	
Old	New
Chart Code: BA	Chart Code: BA
Organization Code: ACAC	Organization Code: ACAC
Organization Name: RPAS ACADEMIC SUPPORT	* Organization Name: RPAS ACADEMIC SUPPO
Organization Manager UserID: OLE4075208273	Organization Manager UserID: OLE4075208273
Organization Manager Principal Name: ole-dmarti - MARTI, DONA D	Organization Manager Principal Name: ole-dmarti MARTI, DONA D
Responsibility Center Code: 80	Responsibility Center Code: 80
Organization Physical Campus Code: BL	Organization Physical Campus Code: BL
Organization Type Code: O - OTHER ORGANIZATIONS	* Organization Type Code: O - OTHER ORGAN
Organization Default Account Number: 6047500	Organization Default Account Number: 6047500
Organization Address Line 1: 801 N. JORDAN AVE.	Organization Address Line 1: 801 N. JORDAN AVE.
Organization Address Line 2:	Organization Address Line 2:
Organization City Name: BLOOMINGTON	Organization City Name: BLOOMINGTON
Organization State/Province Code: IN	Organization State/Province Code: IN
Organization Postal Code: 47405	Organization Postal Code: 47405
Organization Country Code: United States	Organization Country Code: United States
Organization Begin Date: 04/17/2000	* Organization Begin Date: 04/17/2000
Organization End Date:	Organization End Date:
Reports to Chart Code: BA	* Reports to Chart Code: BA
Reports to Organization: PRGE	* Reports to Organization: PRGE
Active Indicator: Yes	Active Indicator: <input checked="" type="checkbox"/>

Edit Organization tab definition

Title	Description
Chart Code	Required. Enter the chart code to which the organization belongs, or search for it from the Chart lookup  .
Organization Code	Required. Enter the code to identify the organization. It must be unique within the chart to which it belongs.
Organization Name	Required. Enter the long descriptive name of the organization.
Organization Manager	Required. Enter the user ID of the manager responsible for the organization or search for it from the UserID lookup  .
Responsibility Center Code	Required. Enter the responsibility center code to which the organization belongs or search for it from the Responsibility Center lookup  .
Organization Physical Campus Code	Required. Enter the campus code which represents the physical location of the organization, or search for it from the Campus lookup  .
Organization Type	Required. Select the type of organization from the Organization Type list or search for it from the lookup  . Examples might include: C =

	Campus R = Responsibility center U = University chart organization O = Other organizations N = Not official
Organization Default Account Number	Required. Enter the primary account used for any account reference for an organization, or search for it from the Account lookup  .
Organization Address 1	Required. Enter the street address where correspondence can be sent to the organization.
Organization Address 2	Optional. Enter the second line of the street address where correspondence can be sent to the organization.
Organization City Name	Display-only. Displays the city where correspondence can be sent to the organization.
Organization State/Province Code	Display-only. Displays the state where correspondence can be sent to the organization.
Organization Postal Code	Required. Enter the zip code assigned by the US Postal Service which relates to the city where the organization is located, or search for it from the Postal Code lookup  .
Organization Country Code	Required. Enter the country where correspondence can be sent to the organization, or search for it from the Country lookup  .
Organization Begin Date	Required. Enter the date when the organization began operations as a new unit. For a new organization this defaults to today's date.
Organization End Date	Optional. Enter the date when the organization was dissolved.
Reports to Chart	Required. Enter the chart code associated with the organization to which the organization reports in the hierarchy, or search for it from the Chart lookup  .
Reports to Organization	Required. Enter the code designating the organization within the hierarchy to which the organization reports, or search for it from the Organization lookup  .
Active Indicator	Optional. Select the check box if the organization code is active and can be used on OLE documents. Clear the check box if it is inactive.

Process Overview

Business Rules

- Chart must be set up in advance
- When creating a new organization with the organization type code ('C: Campus' or 'U: University'), the default account number is not required, since an organization is required to create an account.
- The organization cannot report to itself unless it has an organization type code of 'U'.
- **Reports to Chart and Organization** must follow a path that ends at the known root chart and organization represented by the organization with a type of 'U'.
- When creating a new organization the **Organization Begin Date** must be greater than or equal to today's date.
- When creating a new organization the document may not be blanket approved, except by the OLE-SYS Manager.
- An organization cannot be inactive while there are active accounts or active organizations that report to it.
- If an organization is made inactive, the **Organization End Date** is required.

Routing

The Organization document routes to Org Review based on the organization on the document. It also routes to the Chart Manager for the chart associated with the organization followed by routing to the University Chart Manager.

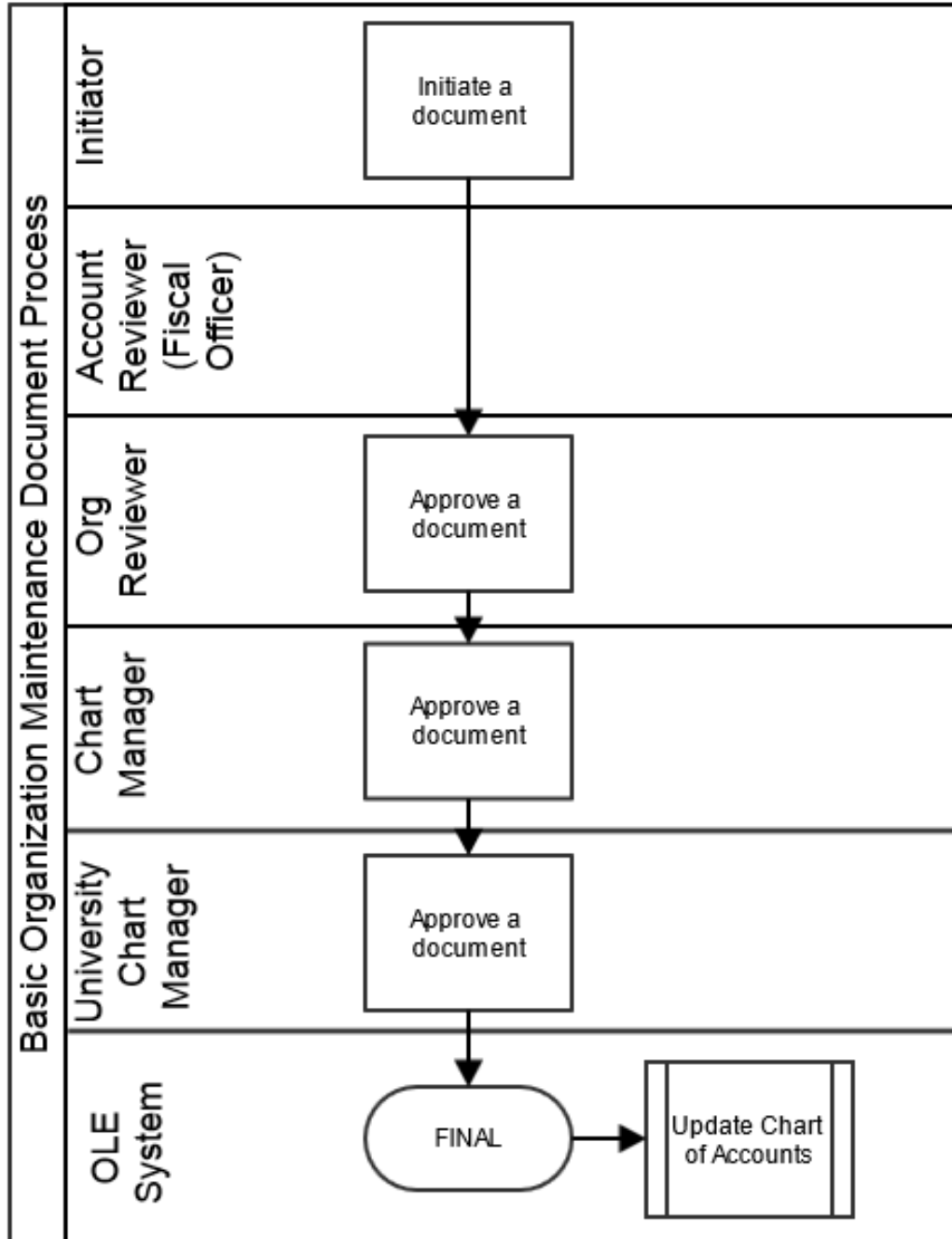

Sub-Account



The Sub-Account document is used to define an optional part of the accounting string that allows tracking of financial activity within a particular account at a finer level of detail. Instead of associating budget, actuals and encumbrances with an account, you can specify a sub-account within that account to apply these entries. Sub-accounts are often used to help track expenses when several different activities may be funded by the same account. Sub-accounts can also be related to each other, across accounts, via Financial Reporting codes.

For example, a large organization may have money in a general account that is used by several different areas of that organization. The organization might segregate the budgets for each of the areas into Sub-accounts such as 'Marketing,' 'Research,' and 'Recruitment. When expenses are applied to the account they can be applied to the sub-account level, allowing direct comparisons between the budget and the actual income and expenditures of these smaller categories. Because all of the activity is still within a single account, it is still easy to report on the finances of the overall account.

Sub-accounts take on most of the attributes of the account to which it reports, including Fiscal Officer, account supervisor, fund group, and function code.

Sub-accounts allow you to take advantage of the Financial Reporting Code. This is an optional sub-account attribute that can be defined by a particular organization and retrieved from the OLE via decision support queries.

Document Layout

The Sub-Account document includes the **Edit Sub-Account Code**, and **Edit Financial Reporting Code** tabs.

Sub-Account ?	Doc Nbr: 3956
	Initiator: ole-k

▼ hide

Document Overview

* Description: <input style="width: 90%;" type="text"/>	Explanation: <input style="width: 95%;" type="text"/>
Organization Document Number: <input style="width: 90%;" type="text"/>	

▼ hide

Edit Sub-Account Code

Old	New
Chart Code: BA	Chart Code: BA
Account Number: 9020224	Account Number: 9020224
Sub-Account Number: 05551	Sub-Account Number: 05551
Sub-Account Name: 20005551	* Sub-Account Name: 20005551
Active Indicator: Yes	Active Indicator: <input checked="" type="checkbox"/>

▼ hide

Edit Financial Reporting Code

Old	New
Financial Reporting Chart Code: <input style="width: 90%;" type="text"/>	Financial Reporting Chart Code: <input style="width: 90%;" type="text"/>
Financial Reporting Org Code: <input style="width: 90%;" type="text"/>	Financial Reporting Org Code: <input style="width: 90%;" type="text"/>
Financial Reporting Code: <input style="width: 90%;" type="text"/>	Financial Reporting Code: <input style="width: 90%;" type="text"/>

Notes and Attachments (0) ▶ show

Ad Hoc Recipients ▶ show

Route Log ▶ show

submit
save
blanket approve
close
cancel

Edit Sub-Account Code Tab

If you are not establishing a Cost Share sub-account or using the Financial Reporting Code, the **Edit Sub-Account Code** and the **Document Overview** tabs are the only required tabs on the document.

▼ hide

Edit Sub-Account Code

Old	New
Chart Code: BA	Chart Code: BA
Account Number: 9020224	Account Number: 9020224
Sub-Account Number: 05551	Sub-Account Number: 05551
Sub-Account Name: 20005551	* Sub-Account Name: 20005551
Active Indicator: Yes	Active Indicator: <input checked="" type="checkbox"/>

Edit Sub-Account Code tab definition

Title	Description
Chart Code	Required. Enter the chart code associated with the account associated with the sub-account, or search for it from the UserID lookup
Account Number	Required. Enter the account number on which you want to create the sub-account or search for it from the Account lookup . If you want to use the same sub-account code on several accounts, you need



	to process an additional document for each additional account on which you want to use that sub-account.
Sub-Account Number	Required. Enter the code to define the sub-account. This is the code to be entered in the sub-account field of the Accounting Lines tab of financial documents.
Sub-Account Name	Required. Enter the long descriptive name. This name appears on the Accounting Lines tab in financial documents as well as in searches and reports.
Active Indicator	Optional. Select the check box if the sub-account is active. Clear the check box if it is inactive.

Edit Financial Reporting Code Tab

This **Financial Reporting Code** tab is optional but can be used to associate this sub-account with a Financial Reporting Code. The associated reporting code could then be retrieved via decision support tools.

Edit Financial Reporting Code ▼ hide	
Old	New
Financial Reporting Chart Code:	Financial Reporting Chart Code: <input type="text"/>
Financial Reporting Org Code:	Financial Reporting Org Code: <input type="text"/>
Financial Reporting Code:	Financial Reporting Code: <input type="text"/>

Edit Financial Reporting Code tab definition

Title	Description
Financial Reporting Chart Code	Optional. Enter the chart code associated with the organization that owns the assigned financial reporting code, or search for it from the Chart lookup 
Financial Reporting Org Code	Optional. Enter the code for the organization that owns the assigned financial reporting code, or search for it from the Org Code lookup 
Financial Reporting Code	Optional. Enter the reporting code assigned to the Sub-Account, or search for it from the Financial Reporting Code lookup  . Financial reporting codes are specific to a chart and organization.

Process Overview

Business Rules

- Takes on most of the attributes of the account to which it reports – fiscal officer, account supervisor; fund group and function code
- If sub-account type code is 'CS,' then the fields **Cost Sharing Chart of Accounts Code** and **Cost Sharing Account Number** in the **Edit CG Cost Sharing** tab are required.
- If sub-account type code is 'EX' and the Account associated with the Sub-Account is a Contracts and Grants account, then all fields in the **Edit CG ICR** tab are required.
- If any field in the **Financial Reporting Code** tab is completed, all fields become required.

Routing

- The Sub-Account document routes to the Fiscal Officer associated with the account on the document.

- The Sub-Account document routes to Org Review based on the organization that owns the account associated with the document.

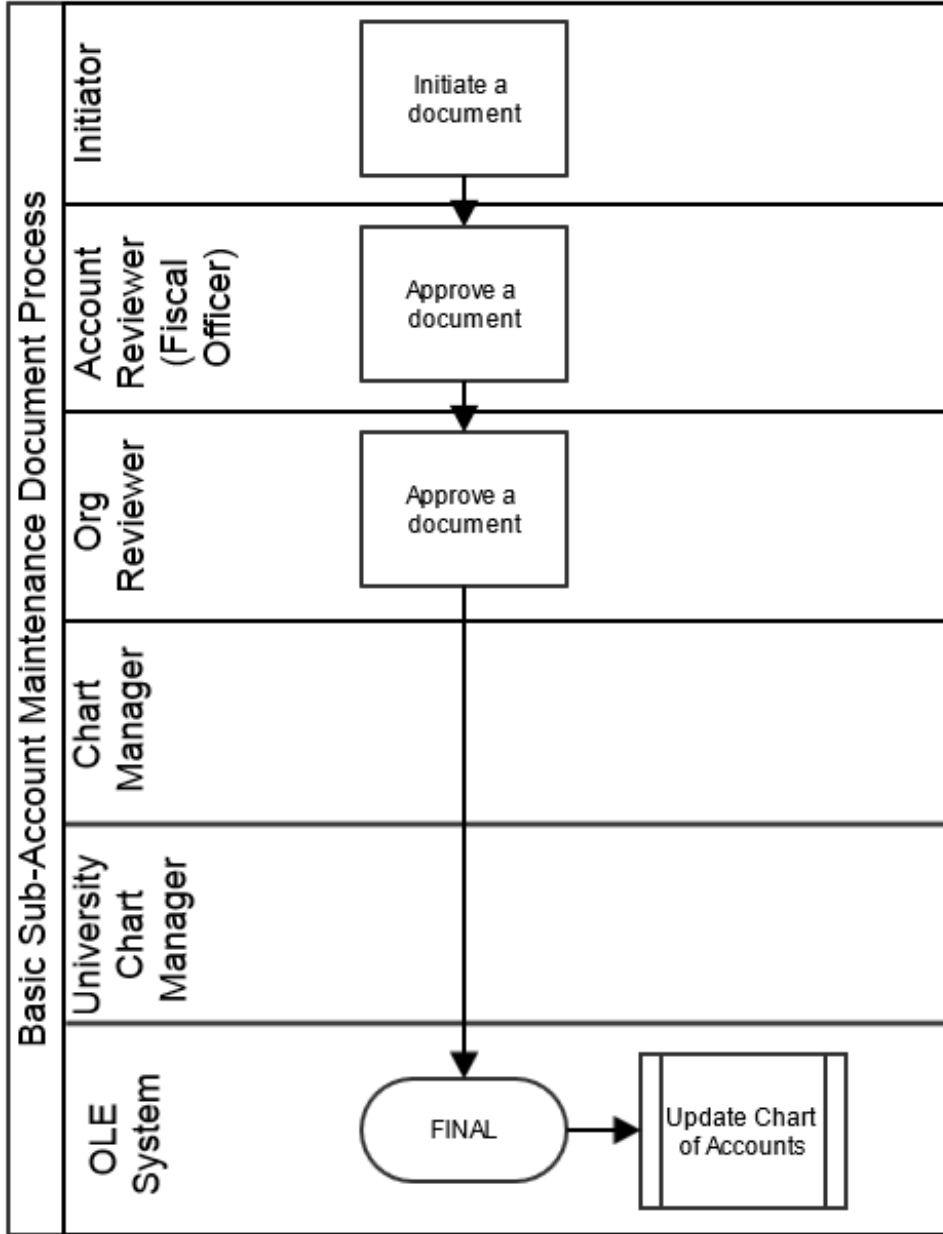

Sub-Object Code

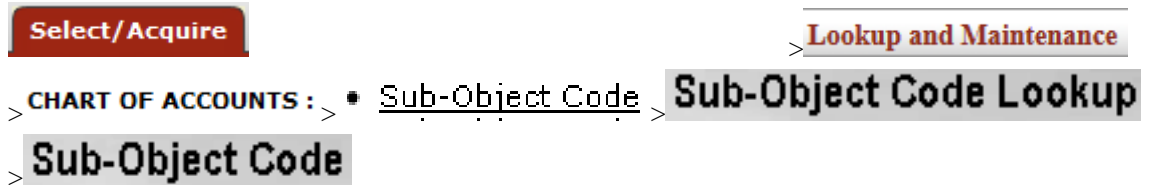

The Sub-Object document is used to define an optional part of the accounting string that allows you to create finer distinctions within a particular object code on an account.

Sub-object codes are specific to an account and a fiscal year and take on most of the attributes of the object code to which they report, including object code type and sub-type.

Document Layout

The Sub-Object Code document contains the **Edit Sub Object Code** tab.

Sub-Object Code		Doc Nbr:
		Initiator:

Document Overview ▼ hide

* Description: <input type="text"/>	Explanation: <input type="text"/>
Org. Doc. #: <input type="text"/>	

Edit Sub Object Code ▼ hide

Old	New
University Fiscal Year: 2010	University Fiscal Year: 2010
Chart Code: BA	Chart Code: BA
Account Number: 6044900	Account Number: 6044900
Object Code: 1466	Object Code: 1466
Sub-Object Code: 001	Sub-Object Code: 001
Sub-Object Code Name: employee parking decal	* Sub-Object Code Name: employee park
Sub-Object Code Short Name: employ park	* Sub-Object Code Short Name: employ park
Active Indicator: Yes	Active Indicator: <input checked="" type="checkbox"/>

Notes and Attachments (0) ▶ show

Ad Hoc Recipients ▶ show

Route Log ▶ show



Edit Sub Object Code Tab

Edit Sub Object Code ▼ hide

Old	New
University Fiscal Year: 2010	University Fiscal Year: 2010
Chart Code: BA	Chart Code: BA
Account Number: 6044900	Account Number: 6044900
Object Code: 1466	Object Code: 1466
Sub-Object Code: 001	Sub-Object Code: 001
Sub-Object Code Name: employee parking decal	* Sub-Object Code Name: employee park
Sub-Object Code Short Name: employ park	* Sub-Object Code Short Name: employ park
Active Indicator: Yes	Active Indicator: <input checked="" type="checkbox"/>

Edit Sub Object Code tab definition

Title	Description
Fiscal Year	Required. Enter the fiscal year when you want to use the sub-object code, or search for it from the Fiscal Year lookup

Chart Code	Required. Enter the chart code to which the sub-object code belongs, or select it from the Chart lookup  .
Account Number	Required. Enter the account number on which you want to use the sub-object code, or select it from the Account lookup  . If you want to use the same sub-object code on several accounts, you need to process an additional document for each additional account on which you want to use that code.
Object Code	Required. Enter the object code to which the sub-object code belongs, or select it from the Object Code lookup  . The sub-object code has its own name and code, but otherwise inherits all attributes of the object code to which it belongs.
Sub-Object Code	Required. Enter the code to define the sub-object. This is the code that should be entered in the sub-object field of the Accounting Lines tab on financial transaction documents.
Sub-Object Code Name	Required. Enter the long descriptive name of the sub-object code. This name appears on the Accounting Lines tab in financial transaction documents as well as in searches and reports.
Sub-Object Code Short Name	Required. Enter the shortened version of the sub-object code name used in reporting where space is limited.
Active Indicator	Optional. Select the check box if the sub-object code is active. Clear the check box if it is inactive.

Process Overview

Business Rules

- The object code associated with the sub-object code must be active.
- Expired accounts are allowed, however, if the account is expired OLE offers to replace it with the continuation account.

Routing

- The Sub-Object document routes to the Fiscal Officer or Primary Delegate associated with the account on the document.
- The Sub-Object document also routes to Org Review based on the organization that owns the account associated with the document.

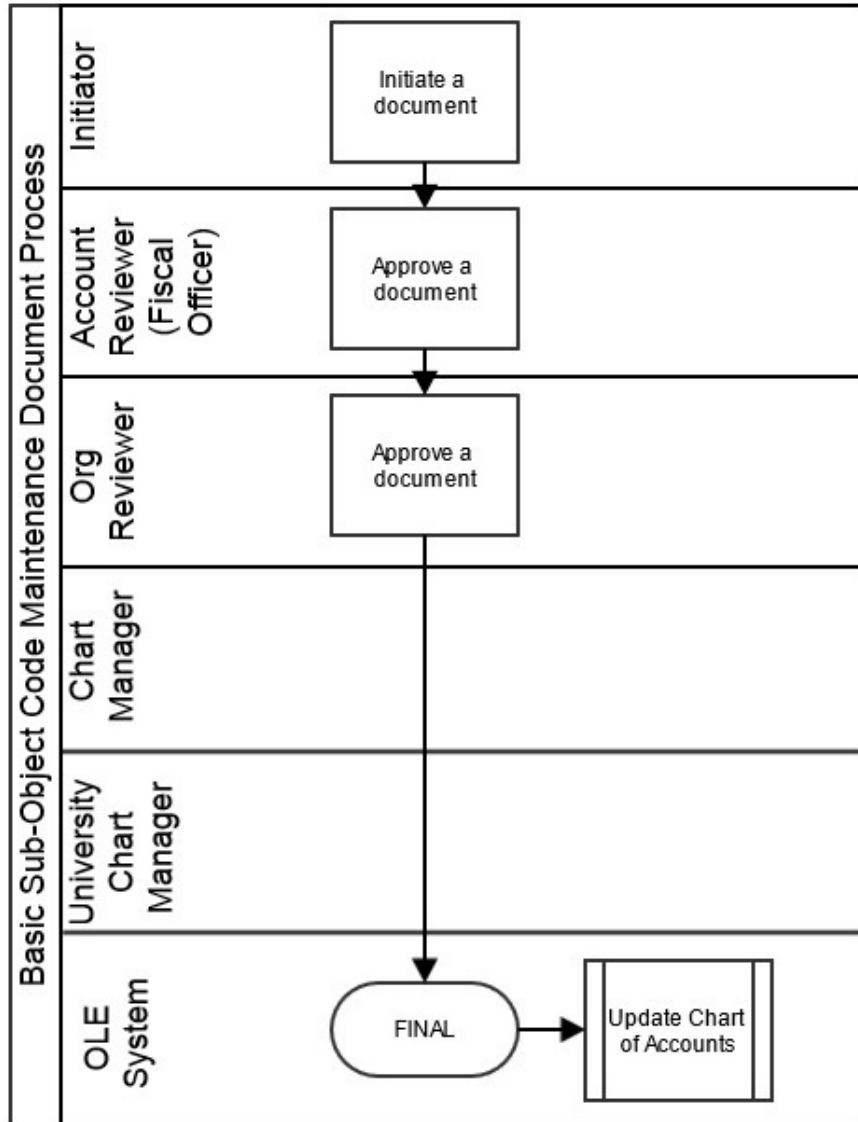

Sub-Object Code Global

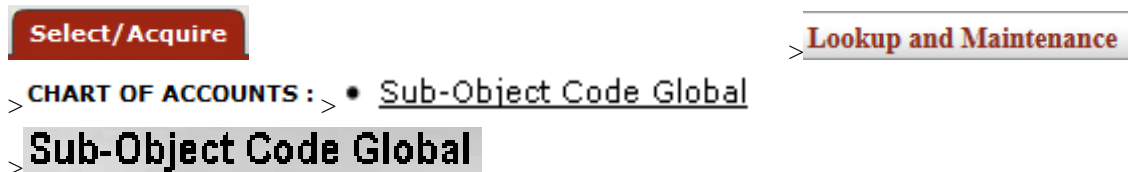

Note

For general information about accessing and working with global documents, see [Global COA E-Docs](#).

The Sub-Object Code Global document is used to assign identical attributes to multiple sub-object codes on a single document.

Document Layout

The Sub-Object Code Global document has three unique tabs: **Edit Global Sub Object Code**, **Edit Object Codes**, and **Edit Accounts**. These tabs contain all of the modifiable sub-object code attributes that are not specific to object codes and account numbers.

Sub-Object Code Global ?
Doc Nbr:
Initiator:

hide

Document Overview

* Description: <input type="text"/>	Explanation: <input type="text"/>
Org. Doc. #: <input type="text"/>	

hide

Edit Global Sub Object Code

New	
* Fiscal Year: <input type="text" value="2010"/>	* Chart Code: <input type="text"/>
* Sub-Object Code: <input type="text"/>	* Sub-Object Code Name: <input type="text"/>
* Sub Object Code Short Name: <input type="text"/>	* Active Indicator: <input checked="" type="checkbox"/>

hide

Edit Object Codes

New Object Code		Look Up
* Fiscal Year: <input type="text" value="2010"/>	* Chart Code: <input type="text"/>	
* Object Code: <input type="text"/>		
<input type="button" value="add"/>		

hide

Edit Accounts

New Account		Look Up
* Account Number: <input type="text"/>	* Chart Code: <input type="text"/>	
Account Name: <input type="text"/>		
<input type="button" value="add"/>		

show

Notes and Attachments (0)

show

Ad Hoc Recipients

show

Route Log

Edit Global Sub Object Code Tab

The **Edit Global Sub Object Code** tab works much the same as the **Edit Sub Object Code** tab of the Sub-Object Code document works. All of the fields on this tab are required. The Sub Object Code Global document can both create new and update existing records.

Edit Global Sub Object Code

New

* Fiscal Year:	2010
* Chart Code:	<input type="text"/>
* Sub-Object Code:	<input type="text"/>
* Sub-Object Code Name:	<input type="text"/>
* Sub Object Code Short Name:	<input type="text"/>
Active Indicator:	<input checked="" type="checkbox"/>

Note

For more information about how to complete the **Edit Global Sub Object Code** tab, see [Sub-Object Code](#).

Edit Object Code Tab

In the **Edit Account** tab, specify the chart and object codes that the sub-object code belongs to. There are two ways to populate the object codes in the **Edit Object** tab. One is by manually entering or selecting one object code at a time from the normal **Object Code** lookup , the other is by using a special multiple value lookup called the **Look Up / Add Multiple Object Code Lines** to return multiple values.

Edit Object Codes

New Object Code Look Up

* Fiscal Year:	2010
Chart Code:	<input type="text"/>
* Object Code:	<input type="text"/>

Edit Account Tab

In the **Edit Account** tab, specify the chart and account that the sub-object code belongs to. There are two ways to populate the accounts that you want to select in the **Edit Account** tab. One is by manually entering or selecting one account at a time from the normal **Account** lookup , the other is by using a special multiple value lookup called the **Look Up / Add Multiple Account Lines** to return multiple values.

Edit Accounts

New Account Lo

Chart Code:	<input type="text"/>
* Account Number:	<input type="text"/>
Account Name:	<input type="text"/>

Note

For information about how to use the multiple value lookup, see [Multiple Value Lookup](#) on the *OLE E-Doc Fundamentals* wiki page.

Process Overview

Business Rules

The Global Sub-Object Code document is subject to the same business rules as the Sub-Object Code document. In addition, at least one account must be selected on the **Edit Accounts** tab and one object code must be selected on the **Edit Object Code** tab.

Routing

The Global Sub-Object Code document routes to the Account Reviewer and Org Reviewer.

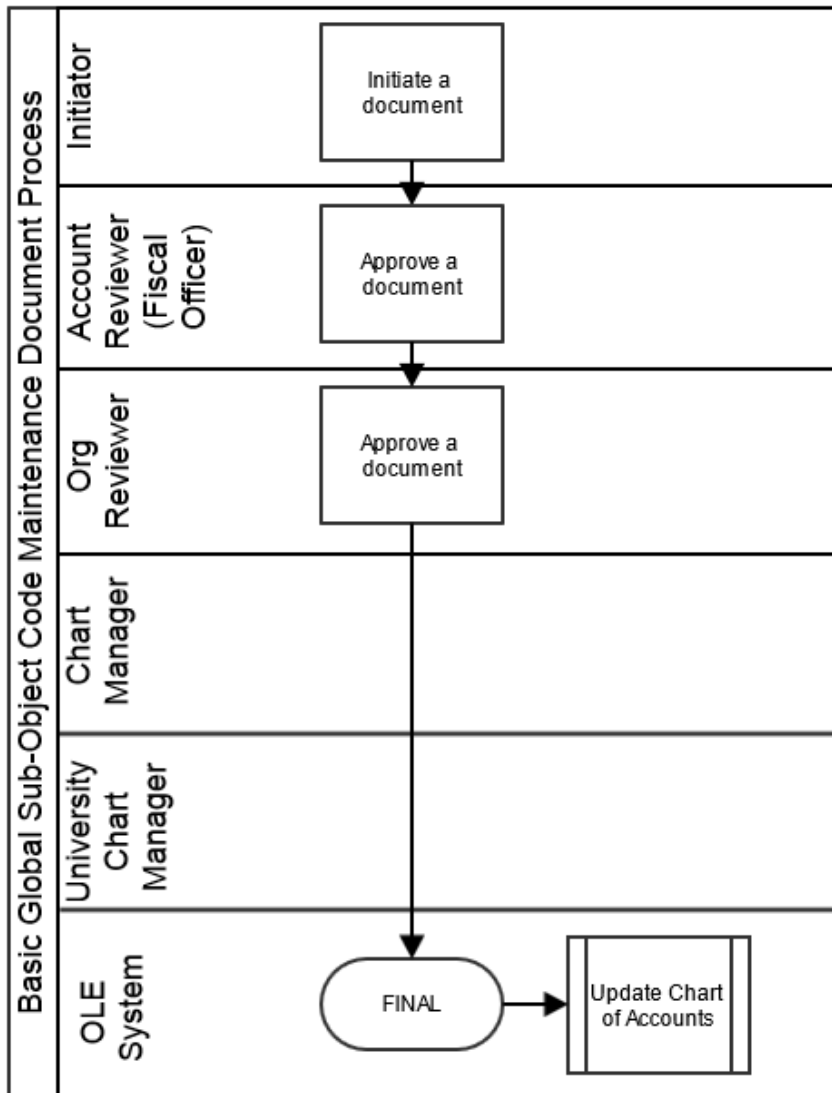



Initiating a Global Sub-Object Code document

Using Look Up / Add Multiple Account and Object Code Lines

18. Complete the **Edit Global Sub Object Code** tab.

19.To add multiple object codes to the **Edit Object Codes** tab, click **Look Up / Add Multiple Object Lines** lookup .

20.Enter the desired search criteria to search for the object codes you want to include and click .

21.After the result is returned, select check boxes to make your object code selection and click . The selected accounts are returned to the **Edit Object Codes** tab.

22.To add multiple accounts to the **Edit Accounts** tab, click the **Look Up / Add Multiple Account Lines** lookup .

23.Enter the desired search criteria to search for the accounts you want to include and click .

24.After the results are displayed, select check boxes to make your account selection and click . The selected accounts are returned to the **Edit Account** tab.

25. Click .

Adding One Account and Object Code at a Time

26.Complete the **Edit Global Sub-Object Code** tab

27. To add one object code at a time, enter the values or use the **Object Code lookup** .

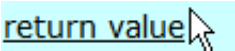
28. Search for an object code and click the  link associated with the object code you want to select.

29. Click  to add the object code to the list.

30.Repeat steps 2 through 4 until you have selected all of the object codes.

31. To add one account at a time, enter the values or use the **Account lookup** .

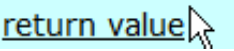
32. Search for an account and click the  link associated with the account you want to select.

33. Click  to add the object code to the list.

34.Repeat steps 2 through 4 until you have selected all of the accounts.

35. Click .

Note

For information about field lookup and multiple value lookup, see [Field Lookup](#) and [Multiple Value Lookup](#) on the *OLE E-Doc Fundamentals* wiki page.

Chapter 10. Vendor (and Document Searches)

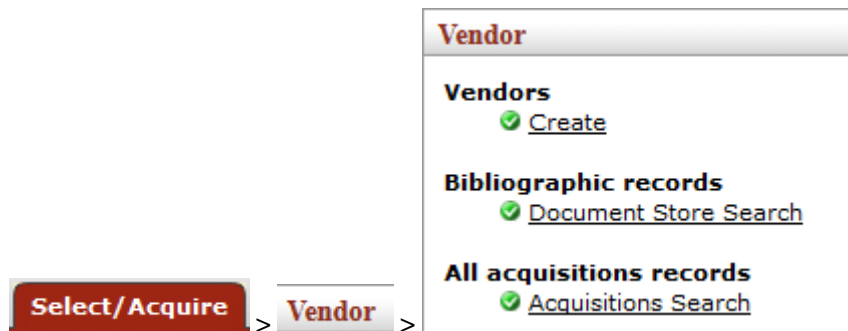

On the Select/Acquire tab, the Vendor submenu provides access for users to create vendors and search for multiple OLE records.

Vendors

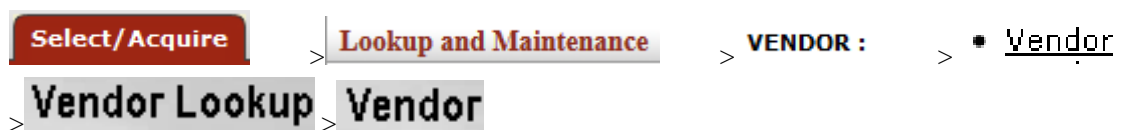

The Vendor (PVEN) document allows users to create and maintain a Vendor table to track businesses or other entities your institution has done or plans to do business with. Each record in this table maintains all information pertinent to a vendor, including tax ID, addresses, contacts and other details required for the management of your institution's procurement process.. Vendors created using this document are available for use on various purchasing documents (such as Requisition, Purchase Order, and Disbursement Voucher documents).

Vendors have many different attributes which may in some cases determine how and when they may be used.

The Vendor document is available from the **Inquiry and Maintenance** menu group on the **Main Menu** tab.

There are three situations where you may choose to use this menu:

- To add a new vendor ('parent Vendor record')
- To create a new division to an existing vendor ('child Vendor record')
- To edit information about an existing vendor or division

Special Navigation Features

For demo purposes, we suggest you use the following library vendors that we specifically created for OLE. The other existing vendors may be experimented upon to test editing, creating new, or adding Divisions to existing vendors.

Vendor name	Vendor search alias	Foreign/domestic
Aleph-Bet Books	ABB	Domestic
D. K. Agencies (P) Ltd.	DKA	Foreign
Otto Harrassowitz	HARRAS	Foreign
YBP Library Services	YBP	Domestic

Wildcards are particularly helpful for searching vendors: *ybp*, harr*.

Note

To learn more about searching, see the section [Searching OLE](#) on the *OLE E-Doc Fundamentals* wiki page.

To create and modify vendors, please sign into OLE as:

Role	Login
Acquisitions-AQ3, AQ4	ole-cstan
Acquisitions-AQ5	ole-ejacob
OLE-PURAP Purchasing Processor (for the Contracts tab)	ole-aferree
OLE ACQ-mgr	ole-hachris
Super user	ole-khuntley

Note

Note: When creating a NEW vendor, if logged in as member of OLE_Acquisitions-AQ3 or AQ4, the new vendor e-doc will be processed, *but* stops at approval. Ole-khuntley or ole-hachris (OLE ACQ-mgr) may create and blanket approve a new vendor.

Foreign Vendor



If the Vendor is Foreign, then additional fields are required, such as **Currency Type** shown in the tab below, and **Is this a foreign vendor** in the **Vendor** main tab. These data values will tie into workflows and currency conversion on requisitions, purchase orders and payment requests, as well as financial accounting with university systems.

Create Division

The Vendor document offers a unique option from the Vendor Detail Lookup screen, called **Create Division**. This option is available only for 'parent' vendors (that is, vendors for which the **Vendor Parent Indicator** on the Vendor tab is set to 'Yes').

The **Create Division** option allows you to group entities under the same corporate office with the same Tax ID ('parent vendor'). You might use this feature to add information about the separate divisions or branches, without having to duplicate the corporate information. A division has a different name from the parent.

Vendor Lookup 

Vendor Name:	<input type="text"/>
Tax Number:	<input type="text"/>
Vendor #:	<input type="text"/>
Active Indicator:	<input checked="" type="radio"/> Yes <input type="radio"/> No <input type="radio"/> Both
Vendor Type:	<input type="text"/> 
State:	<input type="text"/>
Commodity Code:	<input type="text"/> 
Supplier Diversity:	<input type="text"/> 
<input type="button" value="search"/> <input type="button" value="clear"/> <input type="button" value="cancel"/>	

48 items retrieved, displaying all items.

Actions	Vendor Name	Search Alias	Vendor #	Active Indicator	Vendor Type	State
edit create division	ABC CLEANING SERVICES		1000-0	Yes	PQ	NEW YORK
edit create division	ACCOUNTING CONSULTANTS		2005-0	Yes	PQ	INDIANA
edit create division shop	Barnes & Noble.com LLC		4005-0	Yes	PQ	ALASKA
edit create division	BASIC CORP ACTIVE	REGULAR DV 1 SK	1003-0	Yes	DV	INDIANA
edit create division	BASIC VENDOR ESTATE/TRUST		1010-0	Yes	PQ	KENTUCKY
edit	BASIC VENDOR ESTATE/TRUST > B2B CONTRACT VENDOR		1010-3	Yes	PQ	GEORGIA
edit	BASIC VENDOR ESTATE/TRUST > DIVISION 1 OF PO BASIC		1010-1	Yes	PQ	WISCONSIN
edit	BASIC VENDOR ESTATE/TRUST > DIVISION 2 OF PO BASIC		1010-2	Yes	PQ	CALIFORNIA
edit create division	BESCO WATER TREATMENT INC	BBBB FIRST SEARCH ALIAS NAME	2013-0	Yes	PQ	MICHIGAN
edit create division	BOB THE BUILDER	BOB	2003-0	Yes	PQ	OHIO

The **create division** link is available only for the 'parent' vendors. When you click the **create division link**, a new Vendor document is initiated and the information from the **Corporate Information** section of the **Vendor** tab is copied from its Corporate Vendor and remains display-only.

This is an inherited function from KFS. Divisions must be used for full Customer Relationship Management (CRM) type functions. However, if you want to account for a library organization's specific Vendor account number without creating a division, you may enter the **customer number** and the **Organization Code** for the **Account Number Owner** on the **Acquisition Unit Vendor Accounts** tab. You may also add specific vendor discounts associated with the library organization's customer number, as well as **Standard Delivery Carrier** and carrier's standard interval of service (expressed as days/hours).

'Collections'

In the Vendor document, many tabs allow you to enter multiple sets of information ('Collections') for the tab. For example, you may add multiple addresses, contacts, phone numbers, etc. for a single vendor.

To add additional sets of information, complete the tab again and click .

When a set of information is added it is collapsed but may be viewed by clicking  individually.

Supplier Diversity		<input type="button" value="hide"/>
<input type="button" value="hide"/> Supplier Diversity(SMALL BUSINESS)		
	Supplier Diversity:	<u>SMALL BUSINESS</u>
	Active Indicator:	Yes

New	
	Supplier Diversity: <u>SMALL BUSINESS</u> *
<input type="button" value="delete"/>	
New	
	Supplier Diversity: <u>VETERAN OWNED</u> *
<input type="button" value="delete"/>	

Required Fields

In the Vendor document, not all the tabs are required for the creation of the Vendor record. For example, not all the vendors have supplier diversity requirement or multiple phone numbers. Nonetheless the required fields within these tabs are noted with an asterisk in the event that you decide to complete the information.

Document Layout (for Create New Vendor & Create Division)

The Vendor document has various tabs including the **Vendor**, **Transmission Format**, **Address**, **Contact**, **Supplier Diversity**, **Shipping Special Conditions**, **Vendor Commodity Codes**, **Search Alias**, **Vendor Phone Number**, **Acquisitions Unit Vendor Accounts**, and **Contracts** tabs.

The Vendor document is broken into two images below:

Vendor (and Document Searches)

Vendor ?	Doc Nbr: 4268
	Initiator: ole-khuntu

Document Overview ▼ hide

Document Overview

* Description:	<input type="text"/>	Explanation:	<input type="text"/>
Organization Document Number:	<input type="text"/>		

Vendor ▼ hide

New

General Information

Vendor #:	<input type="text"/>
Vendor Linking Id:	<input type="text"/>
Vendor Parent Indicator:	Yes
Vendor Name:	<input type="text"/>
Vendor Last Name:	<input type="text"/>
Vendor First Name:	<input type="text"/>

Corporate Information

* Vendor Type:	<input type="text"/> ▼ 🔍
* Is this a foreign vendor:	<input type="checkbox"/>
Tax Number:	<input type="text"/>
Tax Number Type:	<input type="radio"/> FEIN <input type="radio"/> SSN <input checked="" type="radio"/> NONE
* Ownership Type:	<input type="text"/> ▼ 🔍
Ownership Type Category:	<input type="text"/> ▼ 🔍
W9 Received:	<input type="text"/> ▼
W-8BEN Received:	<input type="text"/> ▼
Backup Withholding Begin Date:	<input type="text"/> 📅
Backup Withholding End Date:	<input type="text"/> 📅
Debarred:	<input type="text"/> ▼

Detail Information

* Currency Type:	<input type="text"/> ▼ 🔍
Payment Terms:	<input type="text"/> ▼ 🔍
* Payment Method:	<input type="text"/> ▼ 🔍
Pre-Payment:	<input type="text"/> ▼
Credit Card:	<input type="text"/> ▼
Taxable Indicator:	<input type="checkbox"/>
Minimum Order Amount:	<input type="text"/>
Shipping Title:	<input type="text"/> ▼ 🔍
Shipping Payment Terms:	<input type="text"/> ▼ 🔍
DUNS Number:	<input type="text"/>
Vendor URL:	<input type="text"/>
Confirmation:	<input type="text"/> ▼
Sold To Vendor Number:	<input type="text"/> 🔍
Sold To Vendor Name:	<input type="text"/>
Restricted:	<input type="text"/> ▼
Restricted Date:	<input type="text"/>
Restricted Person Name:	<input type="text"/>
Restricted By Principal Name:	-
Restricted Reason:	<input type="text"/>
Remit Name:	<input type="text"/>
Active Indicator:	<input checked="" type="checkbox"/>
Inactive Reason:	<input type="text"/> ▼ 🔍

Address
▼ hide

New Address

* Address Type:	<input type="text" value=""/> 🔍
* Address 1:	<input type="text"/>
Address 2:	<input type="text"/>
* City:	<input type="text"/>
State:	<input type="text"/> 🔍
Postal Code:	<input type="text"/>
Province:	<input type="text"/>
* Country:	<input type="text"/> 🔍
Attention:	<input type="text"/>
URL:	<input type="text"/>
Vendor Fax Number:	<input type="text"/>
Email Address:	<input type="text"/>
Set as Default Address:	No ▼
Address Note:	<div style="border: 1px solid #ccc; height: 40px;"></div>
Active Indicator:	<input checked="" type="checkbox"/>

Contact ▶ show

Supplier Diversity ▶ show

Shipping Special Conditions ▶ show

Vendor Commodity Codes ▶ show

Search Alias ▶ show

Vendor Phone Number ▶ show

Acquisition Unit Vendor Accounts ▶ show

Contracts ▶ show

Notes and Attachments (1) ▼ hide

Notes and Attachments				
	Posted Timestamp	Author	* Note Text	Attached File
add:			<div style="border: 1px solid #ccc; height: 20px;"></div>	<input type="button" value="Choose File"/> No file
1	02/21/2013 11:14 AM	HUNTLEY, KEISHA Y	Add vendor document ID 4268	<input type="button" value="CAN"/>

Ad Hoc Recipients ▶ show

Route Log ▶ show

Vendor Tab

The **Vendor** tab collects fundamental information about a vendor such as the name, tax status and details. It is composed of three sections: **General Information**, **Corporate Information** and **Detail Information** sections.

Vendor (and Document Searches)

Vendor	
hide	
New	
General Information	
Vendor #:	
Vendor Linking Id:	
Vendor Parent Indicator:	Yes
Vendor Name:	
Vendor Last Name:	
Vendor First Name:	
Corporate Information	
* Vendor Type:	
* Is this a foreign vendor:	<input type="checkbox"/>
Tax Number:	
Tax Number Type:	<input type="radio"/> FEIN <input type="radio"/> SSN <input checked="" type="radio"/> NONE
* Ownership Type:	
Ownership Type Category:	
W9 Received:	
W-8BEN Received:	
Backup Withholding Begin Date:	
Backup Withholding End Date:	
Debarred:	
Detail Information	
* Currency Type:	
Payment Terms:	
* Payment Method:	
Pre-Payment:	
Credit Card:	
Taxable Indicator:	<input type="checkbox"/>
Minimum Order Amount:	
Shipping Title:	
Shipping Payment Terms:	
DUNS Number:	
Vendor URL:	
Confirmation:	
Sold To Vendor Number:	
Sold To Vendor Name:	
Restricted:	
Restricted Date:	
Restricted Person Name:	
Restricted By Principal Name:	-
Restricted Reason:	
Remit Name:	
Active Indicator:	<input checked="" type="checkbox"/>
Inactive Reason:	

General Information Section

General information includes the Vendor Name and a system-assigned Vendor Number. This number is assigned when the document is approved.

New	
General Information	
Vendor #:	<input type="text"/>
Vendor Linking Id:	<input type="text"/>
Vendor Parent Indicator:	Yes
Vendor Name:	<input type="text"/>
Vendor Last Name:	<input type="text"/>
Vendor First Name:	<input type="text"/>

General Information section definition

Title	Description
Vendor Number	Display-only. A unique, system-generated number that identifies this vendor, assigned at the time the document is approved.
Vendor Linking ID	Locally defined. An identification to link OLE to your university's accounts payable systems
Vendor Parent Indicator	Display only. Indicates whether the vendor is a parent or child record.
Vendor Name	Required if Vendor Last Name and Vendor First Name fields are blank. Enter the vendor name that is not a first and last name. If the vendor should be identified by a first and last name, leave this field blank.
Vendor Last Name	Required if Vendor Name field is blank. Enter the vendor last name. If the vendor should be identified by a company name or title, leave this field blank and use the Vendor Name field.
Vendor First Name	Required if Vendor Name field is blank. Enter the vendor first name. If the vendor should be identified by a company name or title, leave this field blank and use the Vendor Name field.

Note

Either the vendor name or vendor first name and last name are required to identify the vendor.





Corporate Information

The **Corporate Information** section includes the vendor tax information, such as tax number, ownership type, which tax forms are on file and any special withholdings or debarred information.

Corporate Information	
* Vendor Type:	<input type="text"/>
* Is this a foreign vendor:	No <input type="button" value="v"/>
Tax Number:	<input type="text"/>
Tax Number Type:	<input type="radio"/> FEIN <input type="radio"/> SSN <input checked="" type="radio"/> NON
* Ownership Type:	<input type="text"/>
Ownership Type Category:	<input type="text"/>
W9 Received:	<input type="button" value="v"/>
W-8BEN Received:	<input type="button" value="v"/>
Backup Withholding Begin Date:	<input type="text"/> <input type="button" value="calendar"/>
Backup Withholding End Date:	<input type="text"/> <input type="button" value="calendar"/>
Debarred:	<input type="button" value="v"/>

Corporate Information section definition

Vendor (and Document Searches)

Title	Description
Vendor Type	Required. Select the appropriate vendor type from the Vendor Type list or select if from the Vendor Type lookup  . Examples include 'Disbursement Voucher' and 'Purchase Order'. A vendor's type determines on which OLE documents it may be used. Different vendor types are used on different documents
Is this a Foreign Vendor?	Required. Select 'Yes' from the list if the vendor should be identified as foreign. Select 'No' if the vendor is not identified as foreign.
Tax Number	Required for non-foreign vendors. Enter the vendor's tax ID number or SSN.
Tax Number Type	Required. Select the Tax Number Type option that describes the tax number entered in the Tax Number field. If no Tax Number was entered, select 'None'.
Ownership Type	Required. Select the appropriate type from the Ownership Type list, or search for it from the Owner Type lookup  . Examples include 'Corporation,' 'Non-Profit,' and 'Individual/Sole Proprietor'. The ownership type is found on the tax document (W9, W8Ben for example) submitted by the vendor.
Ownership Category	Optional. Select the appropriate category from the Ownership Category list, or search for it from the Owner Category lookup  . The ownership category more specifically identifies the vendor, often indicating the type of services this vendor provides. Examples might include Government or 'Corporation'.
W9 Received	Optional. Select 'Yes' or 'No' from the list to indicate if a W9 has been received for this vendor. Certain types of vendors may be required to have a W9 on file before they may be approved for use.
W-8BEN Received?	Optional. Select 'Yes' or 'No' from the list to indicate if a W-8BEN has been received for this vendor. Certain types of foreign vendors may be required to have a W-8BEN on file before they may be approved for use.
Backup Withholding Begin Date	Optional. Enter the effective date for backup or select it from the calendar  , if the vendor is subject to backup withholdings.
Backup Withholding End Date	Optional. Enter the date to discontinue backup withholding or select it from the calendar  , if the vendor is subject to backup withholdings.
Debarred	Optional. Select 'Yes' or 'No' from the list to indicate whether or not this vendor has been debarred. This designation indicates that an institution has been barred from doing business with this vendor by the state or federal government.

Detail Information Section



The **Detail Information** section contains additional data about the vendor including payment and shipping terms and whether or not they are restricted or inactive and why.

Detail Information	
* Currency Type:	<input type="text"/>
Payment Terms:	<input type="text"/>
* Payment Method:	<input type="text"/>
Pre-Payment:	<input type="text"/>
Credit Card:	<input type="text"/>
Taxable Indicator:	<input type="checkbox"/>
Minimum Order Amount:	<input type="text"/>
Shipping Title:	<input type="text"/>
Shipping Payment Terms:	<input type="text"/>
DUNS Number:	<input type="text"/>
Vendor URL:	<input type="text"/>
Confirmation:	<input type="text"/>
Sold To Vendor Number:	<input type="text"/>
Sold To Vendor Name:	<input type="text"/>
Restricted:	<input type="text"/>
Restricted Date:	<input type="text"/>
Restricted Person Name:	<input type="text"/>
Restricted By Principal Name:	-
Restricted Reason:	<input type="text"/>
Remit Name:	<input type="text"/>
Active Indicator:	<input checked="" type="checkbox"/>
Inactive Reason:	<input type="text"/>

Detail Information section definition

Title	Description
Currency Type	Required. Currency type of the vendor. Select the appropriate currency type from Currency Type list or select it from the Currency Type lookup .
Payment Terms	Optional. Select from the Payment Terms list or select it from the Payment Term Type lookup . Payment terms include the number of days a payment is due and whether a discount is available for prompt payment.
Payment Method	Required. Payment method of the vendor. Select the appropriate method from Payment Method list or select it from the Payment Method lookup .
Pre-Payment	Optional. Select 'Yes' or 'No' from the list to indicate whether or not this vendor accepts pre-payments.
Credit Card	Optional. Select 'Yes' or 'No' from the list to indicate whether or not this vendor accepts credit card payments.
Minimum Order Amount	Optional. Enter an amount if the vendor requires a minimum dollar amount for orders.
Shipping Title	Optional. Select a title from the Shipping Title list or select it from the Shipping Title lookup . The shipping title determines when ownership of the product takes effect. For example destination indicates that ownership takes effect when the product arrives at the delivery location.

Vendor (and Document Searches)

Shipping Payment Terms	Optional. Select the terms from the Shipping Payment Terms list or select it from the Shipping Payment Terms lookup  . This determines whether the institution pays for shipping charges.
DUNS Number	Optional. Enter the nine-digit vendor Data Universal Numbering System (DUNS) number if available. The DUNS number is a unique identifier for businesses that register with Dun and Bradstreet.
Vendor URL	Optional. Enter the URL for the vendor's website.
Confirmation	Optional. Select 'Yes' to indicate that this vendor needs a printed or faxed copy of a PO if the order has been phoned in. Select 'No' if an additional confirmation copy of the PO is not required by the vendor.
Sold To Vendor Number	Enter the number of the vendor that this vendor was sold to or search for the buyer from the Vendor Detail lookup  .
Sold To Name	Display-only. Automatically displayed when the Sold To Vendor is entered.
Restricted	Optional. Select 'Yes' or 'No' from the list to indicate whether or not the use of this vendor is restricted. A restricted vendor is ineligible for APOs.
Restricted Date	Display-only. Automatically displayed by the system when 'Yes' is selected in the Restricted field.
Restricted Person Name	Optional. The system automatically displays the name of the document initiator when 'Yes' is selected for Restricted.
Restricted Reason	Required if Restricted is set to 'Yes'. Enter a text description indicating why this vendor is restricted.
Remit Name	Optional. This field is for information purposes only and does not carry forward to payments requests or disbursement vouchers.
Inactive Reason	Optional. If inactivating a currently active vendor, select a reason from the Inactive Reason list or select it from the Vendor Inactive Reason lookup  . Examples might include 'Sold' or 'Out of Business'.
Active Indicator	Required. Select the check box if the vendor is active. Clear the check box if it is inactive.

Transmission Format Tab



The **Transmission Format** tab allows users to choose how purchase orders will be sent to vendors. Transmission formats could be EDI or PDF files while the transmission type could be set to FTP, Email, Mail, etc.

Be sure to select at least one **Preferred Transmission Format** on the **Transmission format** tab.

After entering the new transmission format information, click  to add it to the document.

▼ hide



New TransmissionFormat

* Transmission Format:	<input type="text"/> 
* Preferred Transmission Format:	<input type="checkbox"/>
* Transmission Type:	<input type="text"/> 
Connection Address:	<input type="text"/>
User Name:	<input type="text"/>
Password:	<input type="text"/>
Active Indicator:	<input checked="" type="checkbox"/>

add

Transmission Format tab definition

Vendor (and Document Searches)

Title	Description
Transmission Format	Required. Transmission format of the vendor. Select the appropriate currency type from the Transmission Format list or select from the Transmission Format lookup 
Preferred Transmission Format	Indicate whether or not the vendor transmission format/type is the preferred one or not. Required. Select the check box if the Transmission Format is the preferred format. Clear the check box if it is not the preferred format.
Transmission Type	Required. Transmission Type of the Transmission Format. Select the appropriate currency type from the Transmission Type list or select from the Transmission Type lookup 
Connection Address	Optional. Address of the transmission type.
User Name	Optional. User Name of the transmission type.
Password	Optional. Transmission Type password.
Active Indicator	Required. Select the check box if the Transmission Format is active. Clear the check box if it is inactive.

Address Tab

The **Address** tab collects address information for a vendor. Different types of addresses may be entered, such as one for mailing purchase orders and another for remittance of payments. Vendors of a particular type may be required to have at least one address of a certain type (such as at least one 'remit to' address). Every vendor must have one default address.



After entering an address, click  to add it to the document.

Note

For more information about adding multiple addresses, see [Collections'](#).



Address
▼ hide

New Address

* Address Type:	<input type="text"/> 
* Address 1:	<input type="text"/>
Address 2:	<input type="text"/>
* City:	<input type="text"/>
State:	<input type="text"/> 
Postal Code:	<input type="text"/>
Province:	<input type="text"/>
* Country:	<input type="text"/> 
Attention:	<input type="text"/>
URL:	<input type="text"/>
Vendor Fax Number:	<input type="text"/>
Email Address:	<input type="text"/>
Set as Default Address:	<input type="text" value="No"/>
Address Note:	<div style="border: 1px solid gray; height: 40px; width: 100%;"></div>
Active Indicator:	<input checked="" type="checkbox"/>



Address tab definition

Title	Description
Address Type	Required. Select an address type from the Address Type list or search for it from the Address Type lookup  .
Address 1	Required. Enter the first line of the address information.
Address 2	Optional. If necessary, enter the second line of the address information.
City	Required. Enter the city name for this address.
State	Optional. Select the state from the State list or select it from the State Code lookup  . State may be required under certain circumstances (such as when entering a US address).
Postal Code	Optional. Enter the postal code for this address. Postal code may be required under certain circumstances (such as when entering a US address).
Province	Optional. Enter the province for this address.
Country	Required. Select a country from the Country list or select it from the Country lookup  .
Attention	Optional. Enter to whose attention it should be directed to, if you want this address to have an attention line.
URL	Optional. Enter a URL you want to associate with this vendor address.
Vendor Fax Number	Optional. Enter the vendor fax number you want to associate with this address.
Email Address	Optional. Enter the vendor email address you want to associate with this address.
Set as Default Address	Required. Select 'Yes' or 'No' from the list to indicate if this address should be used as the default for this vendor or not. Every vendor must have one default address.
Address Note	Optional. Enter additional information for the vendor's address.
Active Indicator	Required. Select the check box if the address is active. Clear the check box if it is inactive.

Contact Tab

The **Contact** tab collects contact information for a vendor. Different types of contacts may be entered, such as sales, technical and customer service representatives.

Contact
▼ hide

New Contact

* Contact Type:	<input type="text" value=""/>
* Name:	<input type="text"/>
Email Address:	<input type="text"/>
Address 1:	<input type="text"/>
Address 2:	<input type="text"/>
City:	<input type="text"/>
State:	<input type="text" value=""/>
Postal Code:	<input type="text"/>
Province:	<input type="text"/>
Country:	<input type="text" value=""/>
Attention:	<input type="text"/>
Comments:	<div style="border: 1px solid gray; height: 40px;"></div>
Active Indicator:	<input checked="" type="checkbox"/>

add

Contact tab definition

Title	Description
Contact Type	Required. Select contact type from the Contact Type list or select it from the Contact Type lookup
Name	Required. Enter the name of the contact.
Email Address	Optional. Enter the email address for this contact.
Address 1	Optional. Enter the first line of the address information for this contact.
Address 2	Optional. Enter the second line of the address information for this contact.
City	Optional. Enter the city name for this contact.
State	Optional. Select the state from the State list or select it from the State Code lookup
Postal Code	Optional. Enter the postal code for this contact.
Province	Optional. Enter the province name for this contact.
Country	Optional. Select the country from the Country list or select it from the Country lookup
Attention	Optional. Enter to whose attention it should be directed to, if you want this address to have an attention line.
Comments	Optional. Enter any additional comments about this contact.
Active Indicator	Required. Select the check box if the contact is active. Clear the check box if it is inactive.

After entering a contact, click add to add it to the document.

Note

For more information about adding multiple contacts, see ['Collections'](#).

Supplier Diversity Tab

The **Supplier Diversity** tab is used to indicate if any recognized supplier diversity categories apply to this vendor. The Small Business Administration has defined supplier diversity categories which may be based on size (small business), ownership (woman or minority owned), and/or geographical location (local).

Supplier Diversity definition

Title	Description
Supplier Diversity	Required when the tab is used. Select the supplier diversity type from the Supplier Diversity list or select it from the Supplier Diversity lookup 
Active Indicator	Required. Select the check box if the supplier diversity type is active. Clear the check box if it is inactive.

After selecting a supplier diversity type, click  to add it to the document.

Note

For more information about adding multiple supplier diversity types, see ['Collections'](#).

Shipping Special Conditions Tab

The **Shipping Special Conditions** tab is used to indicate whether Accounts Payable is allowed to pay for additional freight charged when the vendor invoices for goods or services. Examples might include 'Express,' or 'Insured.'

Shipping Special Conditions tab definition

Title	Description
Shipping Special Conditions	Required. Select the type from the Shipping Special Conditions Type list or select it from the Shipping Special Condition lookup  .
Active Indicator	Required. Select the check box if the shipping special conditions type is active. Clear the check box if it is inactive.

After selecting a shipping special condition, click  to add it to the document.

Note

For more information about adding multiple shipping special condition types, see ['Collections'](#).

Vendor Commodity Codes Tab

The **Vendor Commodity Codes** tab is used to assign commodity codes to this vendor. A commodity code may be added only by a Purchasing Department staff member.

The Purchasing Department assigns commodity codes to vendors in order to track spending by category. A vendor may be assigned multiple commodity codes. For example, a local company that both prints and designs documents might have two different commodity codes, one for printing and one for design.

Note

For information about adding commodity codes, see [Commodity Code](#).

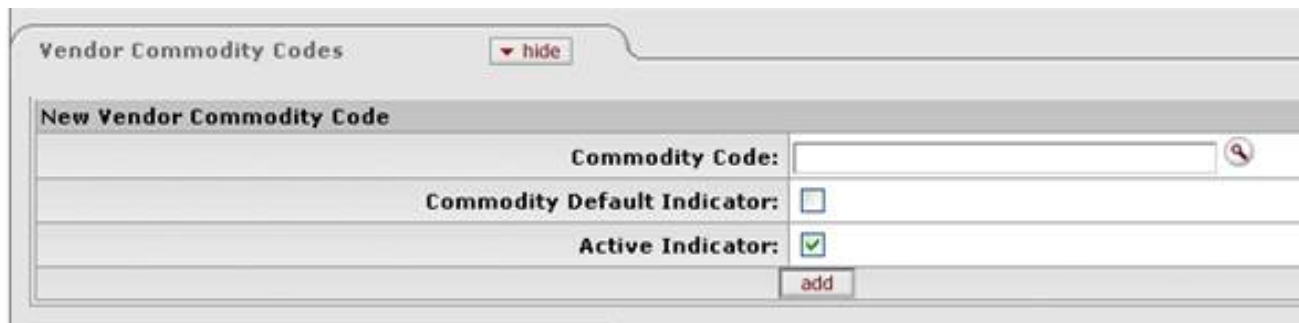

Vendor Commodity Codes tab definition

Title	Description
Commodity Code	Optional. Enter the commodity code.
Commodity Default Indicator	Optional. Select the check box if this commodity code is to be used as the default for this vendor. This commodity code is used on APOs where an institution has indicated that the commodity code is required on POs but not on requisitions. Clear the check box if this commodity code is not to be used as the default.
Active Indicator	Optional. Select the check box if this commodity code is active for this vendor. Clear the check box if it is inactive for this vendor.

After entering a commodity code, click  to add it to the document.

Note

For more information about adding multiple commodity codes, see ['Collections'](#).

Search Alias Tab

The **Search Alias** tab is used to define other names that may be used when searching for this vendor. Search aliases can be used in future lookups as abbreviated forms of long vendor names, or to denote external vendor codes or standard address numbers (SAN). Alias types include Abbreviation, Vendor Code, etc.

Search Alias tab definition

Title	Description
Search Alias Name	Required. Enter the alternate name that may be used to search for this vendor.
Alias Type	Optional. Identify the search alias type or select the type from the Alias Type lookup  .
Active Indicator	Required. Select the check box if the search alias name is active. Clear the check box if it is inactive.

After entering a search alias, click  to add it to the document.

Note

For more information about adding multiple aliases, see ['Collections'](#).

Vendor Phone Number Tab

The **Vendor Phone Number** tab collects phone numbers for this vendor. It may be used to define various types of phone numbers. Examples of different phone number types include 'Toll Free,' 'Mobile,' and 'Purchase Order.'

Vendor Phone Number tab definition

Title	Description
-------	-------------

Phone Type	Required. Select the phone type from the Phone Type list or select it from the Phone Type lookup  .
Phone Number	Required. Enter the phone number.
Extension	Optional. Enter the extension for the phone number.
Active Indicator	Required. Select the check box if the vendor phone number is active. Clear the check box if it is inactive.

After entering a phone number, click  to add it to the document.

Note

For more information about adding multiple phone numbers, see ['Collections'](#).



Acquisition Unit Vendor Accounts Tab

The **Acquisition Unit Vendor Account** tab collects information about numbers the vendor uses to identify your institution. Multiple customer numbers may exist for the same vendor and they are specific to a chart and organization.

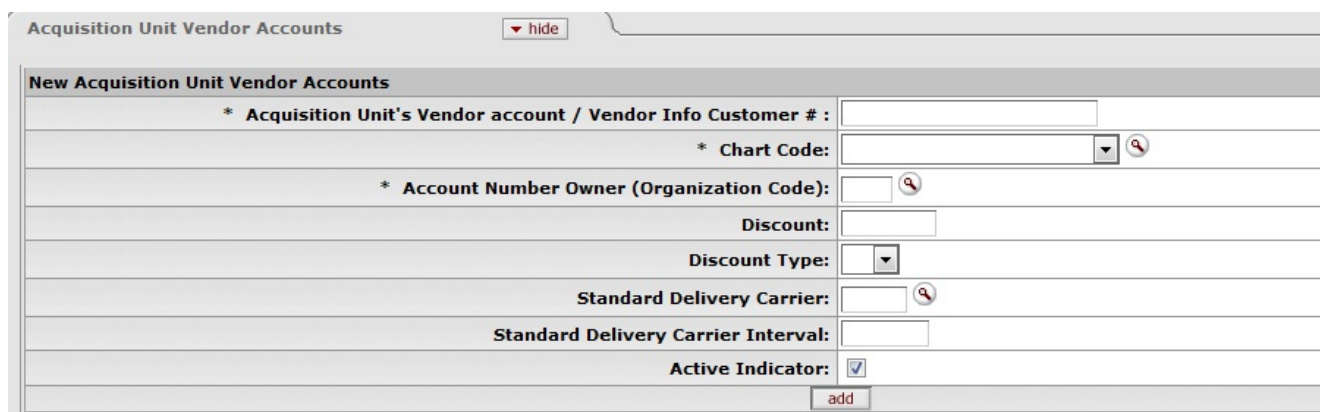
This is where libraries can record local account information for different departments purchasing authority within the same vendor e-doc.



Acquisition Unit Vendor Accounts tab definition

Title	Description
Acquisition Unit's Vendor account / Vendor Info Customer #	Required. Enter the number this vendor uses to identify your institution or organization as a customer.
Chart Code	Required. Select the chart this customer number should be associated with from the Chart Code list or select it from the Chart lookup  .
Account Number Owner (Organization Code)	Optional. Enter an organization code to associate with this customer number or select it from the Organization Code lookup  .
Discount	Optional. Enter the value of the discount.
Discount Type	Optional. Select the type of discount.
Standard Delivery Carrier	Optional. Enter the Delivery Carrier or select it from the Carrier lookup  .
Standard Delivery Carrier Interval	Optional. Enter the days from order date to delivery; used as default claim interval in POs

Vendor (and Document Searches)

Active Indicator

Required. Select the check box if the customer number is active. Clear the check box if it is inactive.

After entering a phone number, click  to add it to the document.

Contracts Tab

The **Contracts** tab collects information about contracts your institution has with this vendor. It includes information such as who manages the contract for your institution, when it begins and ends, any special payment or shipping terms that may specifically apply to the vendor. The **Contracts** tab is viewable only by the members of the OLE-PURAP Purchasing Processor role.

Contracts
▼ hide





New Contract

* Contract Name:	<input type="text"/>
* Description:	<input type="text"/>
* Campus:	<input type="text"/> ▼ 🔍
* Begin Date:	<input type="text"/> 📅
* End Date:	<input type="text"/> 📅
* Contract Manager:	<input type="text"/> ▼ 🔍
* PO Cost Source:	<input type="text"/> ▼ 🔍
* B2B Contract:	No ▼
* Payment Terms:	<input type="text"/> ▼ 🔍
Shipping Terms:	<input type="text"/> ▼ 🔍
Shipping Title:	<input type="text"/> ▼ 🔍
Extension Option Date:	<input type="text"/> 📅
Default APO Limit:	<input type="text"/>
Active Indicator:	<input checked="" type="checkbox"/>



Contracts tab definition

Title	Description
Contract Name	Required. Enter the name used to identify this vendor contract.
Description	Required. Enter a text description that describes the contract.
Campus	Required. Select what institution campus this contract is associated with from the Campus list or select it from the Campus lookup 🔍.
Begin Date	Required. Enter the effective date of the contract or select it from the calendar 📅.
End Date	Required. Enter the expiration date of the contract or select it from the calendar 📅.
Contract Manager	Required. Select the name of the person at your institution who manages this contract from the Contract Manager list or search for it from the Contract Manager lookup 🔍.
PO Cost Source	Required. Select a cost source for this contract from the PO Cost Source list or search for it from the Purchase Order Cost Source lookup 🔍.
B2B Contract	Select the business-to-business contract (yes, no) from the list

Payment Terms	Required. Select the payment terms for this contract from the Payment Terms list or search for it from the Payment Term Type lookup  .
Shipping Terms	Optional. Select the shipping terms for this contract from the Shipping Terms list or search for it from the Shipping Payment Terms lookup  .
Shipping Title	Optional. Select a shipping title for this contract from the Shipping Title list or search for it from the Shipping Title lookup  .
Extension Option Date	Optional. Enter the date up until the contract may be extended or select it from the calendar  .
Default APO Limit	Optional. Enter the upper dollar amount for which automatic purchase orders (APOs) under this contract may be created.
Active Indicator	Required. Select the check box if the contract is active. Clear the check box if it is inactive.

After entering a contract, click  to add it to the document.

Note

For more information about adding multiple contracts, see ['Collections'](#).

Process Overview

Business Rules

- Staff with appropriate levels of security can add, modify or delete data in the vendor record.
- Either **Vendor Name** or **Vendor Last Name** and Vendor First Name fields must be filled.
- If **Vendor Name** field is entered, **Vendor First Name** and Vendor **Last Name** fields must be blank.
- If **Vendor First Name** and **Vendor Last Name** fields have been entered, the **Vendor Name** field must be blank.
- Tax number must be 9-digits and cannot be all zeros.
- The first three digits of an SSN cannot be '000' or '666.
- The middle two digits of an SSN cannot be '00.
- The last four digits of an SSN cannot be '0000.
- The first two digits of a FEIN cannot be '00.
- The vendor's Tax Number must be unique unless it is a division of a parent vendor.
- Vendors of type 'Purchase Order' must have an address of the type 'Purchase Order.
- Vendors of type 'Disbursement Voucher' must have an address of the type 'Remit.
- A vendor must have one and only one address marked as a default address.
- If a country for an address is 'United States' then state and zip code are required.

- Phone and fax numbers must be formatted as ###-###-####.
- If the **Category Allowed Indicator** for a specific ownership type is 'N' (No) then vendor category must be left blank.
- If the **SSN Allowed Indicator** for this ownership type is 'N' (No) then the tax number type must not be SSN.
- If the **FEIN Allowed Indicator** for this ownership type is 'N' (No) then the tax number type must not be FEIN.
- Contract begin date must be earlier than contract end date.

Note

Note: In many of the tabs, at least one address or contact etc. must have **Active Indicator** checked. Otherwise when the user tries to submit the Vendor e-doc, the system will display an error message. If you input any information on the other tabs, then their local tab requirements are noted with asterisks as well.

Routing

- The document does not formally route.

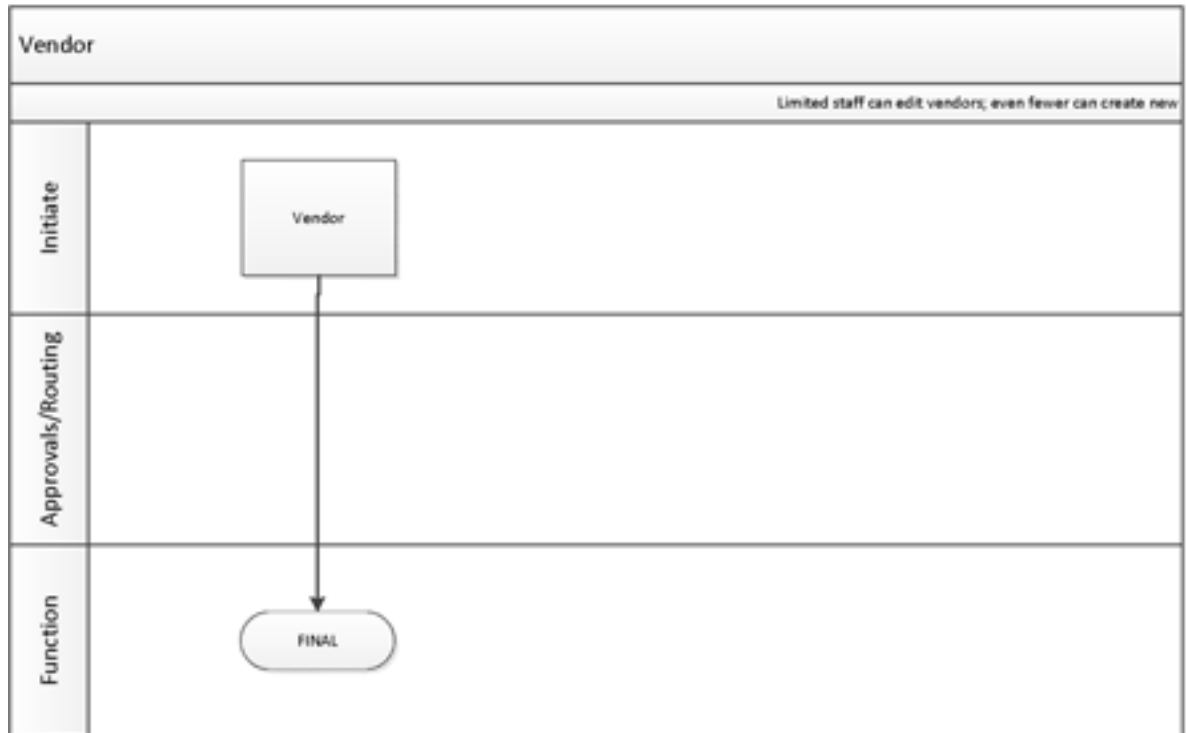

Document Store Discovery

Select/Acquire >
 Vendor >
 Bibliographic records >
 ✔ [Document Store Search](#)

Document Store Search is located on the **Vendor** submenu on the **Select/Acquire** tab. The **Document Store Search** is a content management system for library records such as Bibliographic, Instance (Holdings and Items), Licenses, etc.

Note

Note for searching records: Breadcrumbs are planned for a later release, for now you can navigate through the Doc Store but will want to make note of where you have been if you want to return to the same record.

Performing a Document Store Search

From the **Document Store Search**, bibliographic data in the DocStore can be searched in a variety of ways. Select options from the dropdown menus and enter information to refine the search.

Advanced Search

Document Category Sort By
 Document Type
 Document Format

The following special characters ~,!,(,),{,},[,],',:,- are ignored in search text.

All of these in Search Field:

AND OR NOT

All of these in Search Field:

AND OR NOT

All of these in Search Field:

AND OR NOT

All of these in Search Field:

AND OR NOT

All of these in Search Field:

Advance Search Field Definitions

Title	Description
Document Category	General category of documents being searched.
	<p>Note</p> <p>Work is the only valid category in 1.0</p>

Vendor (and Document Searches)

Document Type	Type of documents associated with a category. For the category Work , these include bibliographic, licenses, Instances, items, etc.
Document Format	Limits searches to a specific data format (i.e., MARC, Dublin Core). Defaults to ALL .
Sort By	Sorts the records by title, author, publication date, and relevance

Five search lines are provided in the Document Store Discovery Layer. Standard Boolean operators (AND, OR, NOT) can be chosen to combine the search terms. Truncation is not automatic in OLE 1.0; the truncation symbol is an asterisk. An asterisk can also be used as a wildcard character within a word.

Note

Known bug: Special characters such as ‘&’ and ‘:’ are not recognized when searching.

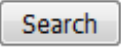
A default sort for the result set can be specified from either the search or the results screen. After all search and sort parameters are entered, click .

Your Search: **DocCategory** - work **DocType** - bibliographic **DocFormat** - all
SearchTerms-(all_text:(mysteries))
 Limited To:(No limits applied)

Limit Your Search...

Author

- Gill, Gillian (1)
- Krefelder Kunstmuseen (Germany) (1)
- McNamara, Frances. (1)

Subject

- Detective and mystery stories -- Periodicals. (1)
- Marcaccio, Fabin, 1963- Exhibitions. (1)
- Pullman Strike, 1894 -- Fiction. (1)

Format

- Book (2)
- Journal/Periodical (1)

Language

- English (2)
- German and English text. (1)

1-3 of 3 results Sort By

1. Agatha Christie : the woman and her **mysteries** /

Local Identifier: 59
 Author: Gill, Gillian
 Publisher: Berlin : Kerber Verlag, 2012.
 Description:
 Subject: Marcaccio, Fabin, 1963- Exhibitions.
 Location:
 Format: Book

UC/DLL/Law-PR6005.H84Z8G5 1990
UC/JRL/Gen-PR6005.H84Z8G5 1990

2. Death at Pullman /

Local Identifier: 120
 Author: McNamara, Frances.
 Publisher: [Forest Park, Ill.] : Allium Press of Chicago, c2011.
 Description:
 Subject: Pullman Strike, 1894 -- Fiction.
 Location:
 Format: Book

UC/JRL/Gen-PS3613.C58583 D43 2011
UC/UCX/Order-PS3613.C58583 PS3613.C58583 D43 2011
B-EDUC/BED-STACKS-PS3613.C5858D43 2008

3. **Mystery** annual.

A short selection of fields from the bibliographic data is displayed for each title.

To refine your search, you can use the **facts** on the left-hand side of the results screen:

▼ **Author**

- Gill, Gillian (1)
- Krefelder Kunstmuseen (Germany) (1)
- McNamara, Frances. (1)

▼ **Subject**

- Detective and mystery stories -- Periodicals. (1)
- Marcaccio, Fabian, 1963- Exhibitions. (1)
- Pullman Strike, 1894 -- Fiction. (1)

▼ **Format**

- Book (2)
- Journal/Periodical (1)

▼ **Language**

Clicking on these returns a smaller, more limited search result set. Clicking on more than one facet reduces the result set even further. The facets being used for limiting results are shown at the top of the results index:

Document Store Discovery

Revise Search New Search

Your Search: **DocCategory** - work **DocType** - bibliographic **DocFormat** - all
SearchTerms-(Title:(mysteries))NOT(Author:(christie))

Limit Your Search... Limited To:Book Gill, Gillian

▼ **Author** 1-1 of 1 results

- Gill, Gillian (1)

▼ **Subject**

1. [Agatha Christie : the woman and her mysteries /](#)

To remove a limit, click on the red [x] next to it.

The search results are then re-displayed with that limit removed.

If you need to see more titles on a screen, each entry can be collapsed to show only its titles. All entries can be collapsed at once by using the **Collapse All** link in the upper right:

Your Search: **DocCategory** - work **DocType** - bibliographic **DocFormat** - marc
SearchTerms-(Title:(ot*ello))NOT(Author:(shak*))
 Limited To:Verdi, Giuseppe, Sound recording

Limit Your Search...

Author

- Verdi, Giuseppe, (61)
- Boito, Arrigo, (15)
- Del Monaco, Mario, (9)
- Gobbi, Tito (7)
- Martinelli, Giovanni, (7)
- more...

Subject

- Operas. (35)
- Opera (Music) -- Music

Selected page:

1-25 of 61 results Sort By Pu

1. **Selezioni da: Otello**
2. **Otello**
3. **Ballet music from Les Vêpres siciliennes, Macbeth, Don Carlos, Otello, Aida**
4. **Otello**

To view more results you may slide or click on the search bar, type in a page number, or hover your mouse near the left of the **Selected page** field to use the up/down arrows. You will then need to click **Go to page**.

Selected page:

1-25 of 54 results

1. **Otello** Giuseppe Verdi.

OLE is designed to search data in a variety of formats. OLE contains bibliographic data in MARC and Dublin Core formats, both stored in XML. The record format is shown at the bottom of the bibliographic information.

2. Death at Pullman /

Local Identifier: 120
 Author: McNamara, Frances.
 Publisher: [Forest Park, Ill.] : Allium Press of Chicago, c2011.
 Description:
 Subject: Pullman Strike, 1894 -- Fiction.
 Location:
 Format: Book

UC/JRL/Gen-PS3613.C58583 D43 2011

PS3613.C58583 D43 2011 B-EDUC/BED-STACKS-PS3613.C5

3. **Mystery** annual.

Just below the bibliographic details for each title are links to the XML versions. Click to open an XML version of the record in a new window or browser tab:

This XML file does not appear to have any style information associated with it. The document tree is shown below.

```
- <OAI-PMH xsi:schemaLocation="http://www.openarchives.org/OAI/2.0/ http://www.openarchives.org/OAI/2.0/OAI-PMH.x
- <ListRecords>
- <record>
- <header>
  <identifier>oai:quod.lib.umich.edu:MIU01-010759290</identifier>
  <timestamp>2011-09-27T01:37:45Z</timestamp>
  <setSpec>hathitrust:pd</setSpec>
</header>
- <metadata>
- <oai_dc:dc xsi:schemaLocation="http://www.openarchives.org/OAI/2.0/oai_dc/ http://www.openarchives.org/OAI
- <dc:title>
  Going public : what writing programs learn from engagement / edited by Shirley K. Rose, Irwin Weiser.
</dc:title>
- <dc:subject>
  English language--Study and teaching (Secondary)--United States.
</dc:subject>
<dc:subject>Language arts (Secondary)--United States.</dc:subject>
<dc:description>259 p. ;</dc:description>
<dc:publisher>Logan, Utah : Utah State University Press,</dc:publisher>
<dc:date>2010.</dc:date>
```

Click to open the Bibliographic Editor.

Note

For more information about the bibliographic editor, see the *Guide to the Describe and Manage Module* in the wiki's [Driver's Manual](#).

Note

Note: The View and Edit buttons will most likely change in future releases.

At any time, you may choose to revise your search or start a new search. These options are located at the top left side of the results screen.

Limit Your Search...

▼ **Author**

Click the **OLE** tab to return to OLE's main portal.

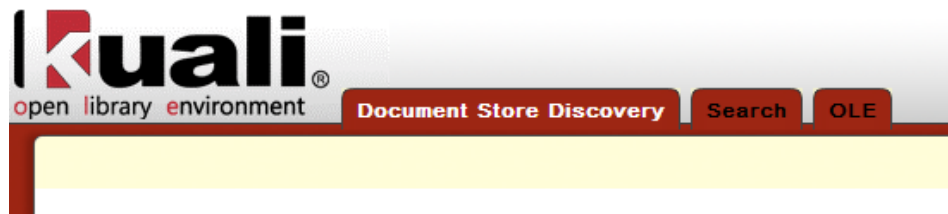

OLE Instance Searching

Some bibliographic search results may include link(s) to one to many Instance (with Holding) and Item records, for those created during acquisitions or as part of OLE sample data:

1. Agatha Christie : the woman and her **mysteries** /

Local Identifier: 59
 Author: Gill, Gillian
 Publisher: Berlin : Kerber Verlag, 2012.
 Description:
 Subject: Marcaccio, Fabin, 1963- Exhibitions.
 Location:
 Format: Book

[View](#) [Edit](#) [UC/DLL/Law-PR6005.H84Z8G5 1990](#) [UC/JRL/Gen-PR6005.H84Z8G5 1990](#) [UC/JRL/Gen-PR6005.H84Z8G5 1990](#)

2. Death at Pullman /

Local Identifier: 120
 Author: McNamara, Frances.
 Publisher: [Forest Park, Ill.] : Allium Press of Chicago, c2011.
 Description:
 Subject: Pullman Strike, 1894 -- Fiction.
 Location:
 Format: Book

[View](#) [Edit](#) [UC/JRL/Gen-PS3613.C58583 D43 2011](#) [UC/UCX/Order-PS3613.C58583 D43 2011](#) [UC/JRL/Gen-PS3613.C58583 D43 2011](#) [B-EDUC/BED-STACKS-PS3613.C5858D43 2008](#)

You may select the **call number** link to see the Instance metadata, or link from it to further Holding or Item(s) data. There is limited data in the Item records that have been added to the Document Store. To return to the Bibliographic description, click the **Title** link.

To return to your search results, use your browser's navigation.

At present, users only have the **Search Field** option "source" available when searching Instance documents, but can further search Holdings data like below:

Advanced Search

Document Category Sort By

Document Type

Document Format

The following special characters ~,!,(,),{,},[,],',:,- are ignored in search text.

All of these in Search Field:

AND OR NOT

All of these in Search Field:

AND OR NOT

All of these in Search Field:

All

Local Identifier

Call Number

Call Number Prefix

Call Number Type Code

Call Number Type Name

Shelving Order

Uri

Holdings Note

Receipt Status Code

Location

Or further, test searching on Item data.

Advanced Search

Document Category Sort By

Document Type

Document Format

The following special characters ~,!,(,),{,},[,],',:,- are ignored in search text.

All of these in Search Field:

AND OR NOT

All of these in Search Field:

AND OR NOT

All of these in Search Field:

AND OR NOT

All of these in Search Field:

All

Local Identifier

Call Number

Call Number Prefix

Call Number Type Code

Call Number Type Name

Shelving Order

Item Identifier

Item Status Code

Item Barcode

Item Uri

Purchase Order Line Item Identifier

Vendor Line Item Identifier

Barcode ARSL

Statistical Searching Code

Statistical Searching Name

Item Type Name

Item Type Code

Copy Number

Enumeration

Facets for Holdings and Item data (such as location, call number sorting, etc.) will be designed and released in the future.

Notes and Tips on Bib, Instance and Item searching

- Breadcrumbs are planned for a later release, for now you can navigate through the DocStore but will want to make note of where you have been if you want to return to the same record.
- If you use multiple words in your search, only one gets highlighted in the search results, and it's the first word that appears in the document (not the first word in your list of search terms).
- If you search for a word in plural form, OLE will show results for the singular form as well.

- Click the **OLE** tab to return to OLE's main portal.

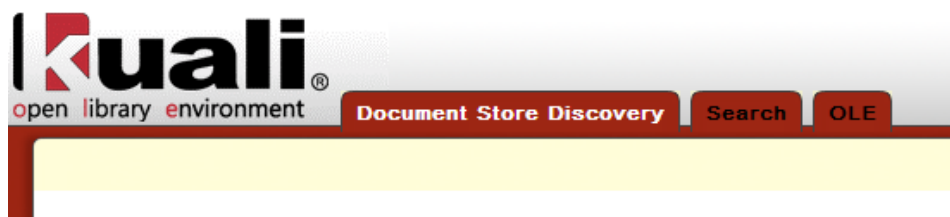

Click to see Instance, Holdings or Items in their raw .xml form. OLE will generate new Instance/Holding/Item documents during the Import or Load process or during Requisition-to-Purchase Order creation. You may also create and edit Instances through the Instance Editor.

Note

For more information about the Instance editor, see the *Guide to the Describe and Manage Module* in the wiki's [Driver's Manual](#).

Acquisitions Search

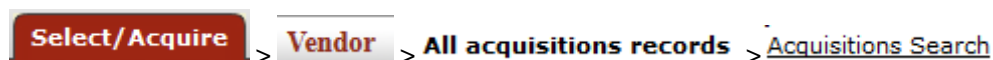

OLE offers a general search for acquisition e-docs. The search screen contains the standard acquisition and bibliographic search fields.

Using the bibliographic search fields will result in acquisition documents pertaining to that title.

Note

For information about performing a search for one or more credit memos, see [Performing Acquisition Searches](#) on the *OLE E-Doc Fundamentals* wiki page.

Chapter 11. Vendor Attribute Maintenance E-Docs

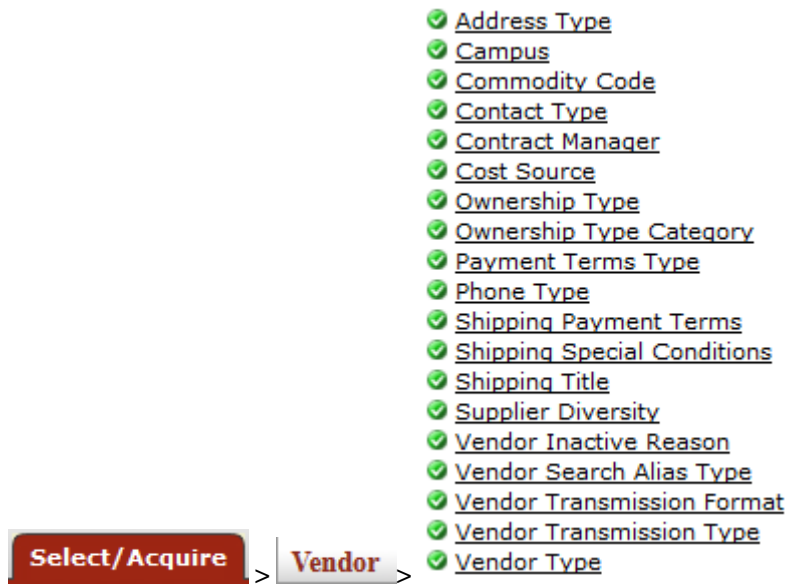

The Maintenance Menu provides access to many vendor-related e-docs that allow you to update vendor attributes used by the Vendor document.

Address Type



The Address Type document is used to establish codes used to categorize various types of vendor addresses. These types can be used to identify different addresses for different purposes, such as defining one address to which purchase orders should be sent and another address to which tax documents should be addressed.

Document Layout

Address Type ?

Doc Nbr: 3245
Initiator: khuntley

Document Overview ▼ hide

Document Overview	
* Description:	<input type="text"/>
Org. Doc. #:	<input type="text"/>
Explanation:	<input type="text"/>

Edit Address Type ▼ hide

Old	New
Address Type Code: PO	Address Type Code: PO
Address Type Description: PURCHASE ORDER	* Address Type Description: PURCHASE ORD
Default Indicator: Yes	Default Indicator: <input checked="" type="checkbox"/>
Active Indicator: Yes	Active Indicator: <input checked="" type="checkbox"/>

Notes and Attachments (0) ▶ show

Ad Hoc Recipients ▶ show

Route Log ▶ show

submit
save
blanket approve
close
cancel

The Address Type document includes the **Edit Address Type** tab. The system automatically enters data into both the **Old** and **New** sections in this tab. Selected data fields are available for editing.

Edit Address Type tab definition

Title	Description
Address Type Code	The code to identify a type of vendor address.
Address Type Description	Required. The familiar title of the vendor addresses type.
Default Indicator	Optional. Select the checkbox if an address of this type can be marked as the default address for a vendor. Clear the checkbox if it should not be used as a default.
Active Indicator	Indicates whether this vendor address is active or inactive. Remove the check mark to deactivate.

Campus

Select/Acquire

>

Vendor

>

✔

Campus

>

Campus Parameter Lookup

>

Campus Parameter

The Campus document defines basic identifying attributes of a campus-level purchasing unit at your institution.

Document Layout

Campus Parameter ?		Doc Nbr: 3246
		Initiator: khuntle

Document Overview ▼ hide

* Description: <input style="width: 95%;" type="text"/>	Explanation: <input style="width: 95%;" type="text"/>
Org. Doc. #: <input style="width: 80%;" type="text"/>	

Edit Campus Parameter ▼ hide

Old	New
Campus Code: BL	Campus Code: BL
Campus Purchasing Director Name: SALLY SMITH	Campus Purchasing Director Name: SALLY SMITH
Campus Purchasing Director Title: UNIVERSITY DIRECTOR OF PURCHASING	Campus Purchasing Director Title: UNIVERSITY DIRECTOR OF PUR
Campus Accounts Payable Email Address:	Campus Accounts Payable Email Address:
Purchasing Institution Name: UNIVERSITY OF HIGHER ED	Purchasing Institution Name: UNIVERSITY OF HIGHER ED
Purchasing Department Name: PURCHASING DEPARTMENT	Purchasing Department Name: PURCHASING DEPARTMENT
Address 1: ONE MAIN STREET	Address 1: ONE MAIN STREET
Address 2:	Address 2:
City: SOME CITY	City: SOME CITY
State: ALASKA	State: ALASKA
Postal Code: 99334	Postal Code: 99334 <input style="width: 20px;" type="text"/>
Country: UNITED STATES	Country: UNITED STATES
Active Indicator: Yes	Active Indicator: <input checked="" type="checkbox"/>

Notes and Attachments (0) ▶ show

Ad Hoc Recipients ▶ show



Route Log ▶ show

submit
save
blanket approve
close
cancel

The Campus Parameter document includes the **Edit Campus Parameter** tab. The system automatically enters data into both the **Old** and **New** sections in this tab. Selected data fields are available for editing.

Edit Campus Parameter tab definition

Title	Description
Campus Code	The campus code for which the parameters are used.
Campus Purchasing Director Name	The name of the purchasing director associated with this campus.
Campus Purchasing Director Title	The title of the purchasing director for this campus.
Campus Accounts Payable Email Address	The accounts payable email address for this campus.
Purchasing Institution Name	The institution's name that is associated with this campus code.
Purchasing Department Name	The Purchasing Department name for this campus.
Address 1	The first line of the address for this campus office.

Address 2	The second line of the address for this campus office.
City	The city for this campus office.
State	The state for this campus office. Existing state codes may be retrieved from the list or from the lookup  .
Postal Code	The postal code for this campus office.
Country	The country for this campus office. Existing restricted status codes may be retrieved from the list or from the lookup  .
Active Indicator	Indicates whether this campus parameter is active or inactive. Remove the check mark to deactivate.

Commodity Code



The Commodity Code document defines categories of items purchased from a vendor by assigning a set of attributes to a code.

Document Layout

Commodity Code ?	Doc Nbr: 3247
	Initiator: khuntley

Document Overview ▼ hide

Document Overview

* Description: <input type="text"/>	Explanation: <input type="text"/>
Org. Doc. #: <input type="text"/>	

Commodity Code ▼ hide

Old	New
Commodity Code: 11	Commodity Code: 11
Commodity Description: Agriculture, Forestry, Fishing and Hunting	* Commodity Description: Agriculture, Fores
Sales Tax Indicator: Yes	Sales Tax Indicator: <input checked="" type="checkbox"/>
Restricted Items Indicator: No	Restricted Items Indicator: <input type="checkbox"/>
Sensitive Data: <input type="text"/>	Sensitive Data: <input type="text"/>
Active Indicator: Yes	Active Indicator: <input checked="" type="checkbox"/>

Contract Managers ▼ hide

New Contract Manager

* Campus Code: <input type="text"/>	
* Contract Manager: <input type="text"/>	

Notes and Attachments (0) ▶ show

Ad Hoc Recipients ▶ show

Route Log ▶ show

The Commodity Code document includes the **Commodity Code** tab and the **Contract Managers** tab.

Commodity Code Tab



Commodity Code ▼ hide	
Old	New
Commodity Code: 11	Commodity Code: 11
Commodity Description: Agriculture, Forestry, Fishing and Hunting	* Commodity Description: Agriculture, F
Sales Tax Indicator: Yes	Sales Tax Indicator: <input checked="" type="checkbox"/>
Restricted Items Indicator: No	Restricted Items Indicator: <input type="checkbox"/>
Sensitive Data:	Sensitive Data:
Active Indicator: Yes	Active Indicator: <input checked="" type="checkbox"/>

The system automatically enters data into both the **Old** and **New** sections of this tab. Selected data fields are available for editing.

Commodity Code tab definition

Title	Description
Commodity Code	The commodity code. Commodity codes can be used to categorize purchases. OLE is not delivered with a commodity code structure, but the system is designed so that industry standards can be loaded into the table or your organization can adopt its own coding structure.
Commodity Code Description	Required. A description of the commodity code.
Sales Tax Indicator	Indicates if sales tax applies to this commodity code. Remove the check mark if sales tax does not apply.
Restricted Items Indicator	Indicates if this is a commodity code of restricted items. Remove the check mark if there are no restrictions on items associated with this commodity code.
Sensitive Data	Optional. The type of sensitive data for the commodity code. Existing sensitive data descriptions may be retrieved from the list or from the  lookup.
Active Indicator	Indicates whether this commodity code is active or inactive. Remove the check mark to deactivate.

Contract Managers Tab



Contract Managers ▼ hide	
New Contract Manager	
* Campus Code:	<input type="text"/> 
* Contract Manager:	<input type="text"/> 

Note that multiple **Campus Code/Contract Manager** combinations may be assigned to the commodity code by clicking **add** after entering data for each combination.

Note

For more information about assigning multiple Campus Code/Contract Manager combinations, see ['Collections'](#).

Contract Managers tab definition

Title	Description
Campus Code	Required. The campus for the commodity code. Existing campus codes may be retrieved from the list or from the lookup  .
Contract Manager	Required. The contract manager for the commodity code. Existing contract managers may be retrieved from the list or from the lookup  .

Contact Type



The Contact Type document is used to establish various roles of the vendor contact, which may assist in determining how inquiries should be directed to the vendor. Examples of contact types include 'Accounts Receivable,' 'Sales Rep,' and 'Customer Service.'

Document Layout

Contact Type ?		Doc Nbr: 3248
		Initiator: khuntle

Document Overview hide

Document Overview

* Description:	<input type="text"/>	Explanation:	<input type="text"/>
Org. Doc. #:	<input type="text"/>		

Edit Contact Type hide

Old		New	
Contact Type Code:	SE	Contact Type Code:	SE
Contact Type Description:	SERVICE/MAINTENANCE	* Contact Type Description:	SERVICE/MA
Active Indicator:	Yes	Active Indicator:	<input checked="" type="checkbox"/>

Notes and Attachments (0) show

Ad Hoc Recipients show

Route Log show

submit save blanket approve close cancel

The Contact Type document includes the **Edit Contact Type** tab. The system automatically enters data into both the **Old** and **New** sections of this tab. Selected data fields are available for editing.

Edit Contact Type tab definition

Title	Description
Vendor Contact Type Code	The code used to identify a type of vendor contact.
Vendor Contact Type Description	Required. The title of the contact type.
Active Indicator	Indicates whether this contact type is active or inactive. Remove the check mark to deactivate.

Contract Manager

Select/Acquire > Vendor > Contract Manager >
Contract Manager Lookup > Contract Manager

The Contract Manager document is used to establish the list of individuals at the institution who are responsible for managing contracts for specific vendors. When associating a contract with a vendor in the Vendor document, a Contract Manager must be selected.

Document Layout

Contract Manager ?		Doc Nbr: 3249
		Initiator: khuntle

Document Overview hide

* Description:	<input type="text"/>	Explanation:	<input type="text"/>
Org. Doc. #:	<input type="text"/>		

Edit Contract Manager hide

Old	New
Contract Manager Code: 10	Contract Manager Code: 10
Contract Manager Name: WILLIE PARKE	* Contract Manager Name: WILLIE PARK
Published Phone Number: 555-555-5555	* Published Phone Number: 555-555-5555
Published Fax Number: 444-444-4444	* Published Fax Number: 444-444-4444
Contract Manager Delegation Dollar Limit: 15,000.00	* Contract Manager Delegation Dollar Limit: 15,000.00
Active Indicator: Yes	* Active Indicator: <input checked="" type="checkbox"/>

Notes and Attachments (0) show

Ad Hoc Recipients show

Route Log show

submit save blanket approve close cancel

The Contract Manager document includes the **Edit Contract Manager** tab. The system automatically enters data into both the **Old** and **New** sections in this tab. Selected data fields are available for editing.

Edit Contract Manager tab definition

Title	Description
Contract Manager Code	The code used to identify this contract manager.
Contract Manager Name	Required. The contract manager's name.
Published Phone Number	The published phone number of the contract manager, including area code.
Published Fax Number	Required. The published fax number of the contract manager, including area code.
Contract Manager Delegation Dollar Limit	Required. The upper dollar amount for which this contract manager is allowed to delegate approval authority.
Active Indicator	Indicates whether this contract manager is active or inactive. Remove the check mark to deactivate.

Cost Source

Select/Acquire > Vendor > • Cost Source > Cost Source Lookup >
Cost Source

The Cost Source document is used to establish codes that identify the method used to determine the pricing for a purchase order. Examples might include 'Quote', 'Estimate', 'Pricing Agreement', or the name of an affiliation that has negotiated a contract with one or more vendors.

Document Layout

Cost Source ?

Doc Nbr: 3250
Initiator: khuntle

Document Overview
▼ hide

Document Overview

* Description: <input style="width: 90%;" type="text"/>	Explanation: <input style="width: 90%;" type="text"/>
Org. Doc. #: <input style="width: 90%;" type="text"/>	

Edit Cost Source
▼ hide

Old	New
Cost Source Code: COOP	Cost Source Code: COOP
Cost Source Description: COOPERATIVE AGREEMENT	* Cost Source Description: COOPERATIV
Item Unit Price Lower Variance Percent: 0	* Item Unit Price Lower Variance Percent: <input style="width: 40px;" type="text" value="0"/>
Item Unit Price Upper Variance Percent: 0	* Item Unit Price Upper Variance Percent: <input style="width: 40px;" type="text" value="0"/>
Active Indicator: Yes	Active Indicator: <input checked="" type="checkbox"/>

Notes and Attachments (0)
▶ show

Ad Hoc Recipients
▶ show

Route Log
▶ show

submit
save
blanket approve
close
cancel

The Cost Source document includes the **Edit Cost Source** tab. The system automatically enters data into both the **Old** and **New** sections in this tab. Selected data fields are available for editing.

Edit Cost Source tab definition

Title	Description
Cost Source Code	The code used to identify this purchase order cost source.
Cost Source Description	Required. The familiar title of the purchase order cost source.
Item Unit Price Lower Variance Percent	Required. Payment will not be made if the price variance is lower by this percentage.
Item Unit Price Upper Variance Percent	Required. Payment will not be made if the price variance is higher by this percentage.
Active Indicator	Indicates whether this cost source code is active or inactive. Remove the check mark to deactivate.

Ownership Type

Select/Acquire

>

Vendor

>

•

Ownership Type

>

Ownership Type Lookup

>

Ownership Type

300

The Ownership Type document is used to define the vendor for tax and reporting purposes, indicating for example, that the vendor is an individual, corporation, or non-profit entity. It also indicates if vendors of this type can be further defined using an Ownership Category.

Document Layout

Ownership Type ?

Doc Nbr: 3251
Initiator: khuntl

Document Overview
▼ hide

* Description: <input style="width: 90%;" type="text"/>	Explanation: <input style="width: 90%;" type="text"/>
Org. Doc. #: <input style="width: 80%;" type="text"/>	

Edit Ownership Type
▼ hide

Old	New
Ownership Code: CP	Ownership Code: CP
Ownership Description: CORPORATION	* Ownership Description: CORPORATION
Ownership Type Category Allowed Indicator: Yes	Ownership Type Category Allowed Indicator: <input checked="" type="checkbox"/>
Active Indicator: Yes	Active Indicator: <input checked="" type="checkbox"/>

Notes and Attachments (0) ▶ show

Ad Hoc Recipients ▶ show

Route Log ▶ show

submit
save
blanket approve
close
cancel

The Ownership Type document includes the **Edit Ownership Type** tab. The system automatically enters data into both the **Old** and **New** sections in this tab. Selected data fields are available for editing.

Edit Ownership Type tab definition

Title	Description
Ownership Code	The code used to identify this ownership type.
Ownership Description	Required. The familiar title of the ownership type.
Ownership Type Category Allowed Indicator	Indicates if a vendor with this ownership type is allowed to have an ownership category. Remove the check mark if ownership category is not allowed.
Active Indicator	Indicates whether this ownership type code is active or inactive. Remove the check mark to deactivate.

Ownership Type Category

Select/Acquire
>
Vendor
>
• Ownership Type Category
>

Ownership Type Category Lookup
>

Ownership Type Category
>

Certain ownership types allow the selection of further refining ownership type category. The Ownership Type Category document further defines a vendor's ownership within Ownership Type.

Document Layout

Ownership Type Category ?

Doc Nbr: 3252
Initiator: khuntle

Document Overview
▼ hide

Document Overview	
* Description: <input style="width: 95%;" type="text"/>	Explanation: <input style="width: 95%;" type="text"/>
Org. Doc. #: <input style="width: 95%;" type="text"/>	

Edit Ownership Type Category
▼ hide

Old	New
Ownership Type Category Code: LE	Ownership Type Category Code: LE
Ownership Type Category Description: LEGAL SERVICES	* Ownership Type Category Description: LEGAL SERVI
Active Indicator: Yes	Active Indicator: <input checked="" type="checkbox"/>

Notes and Attachments (0)
▶ show

Ad Hoc Recipients
▶ show

Route Log
▶ show

submit
save
blanket approve
close
cancel

The Ownership Category document includes the **Edit Ownership Category** tab. The system automatically enters data into both the **Old** and **New** sections in this tab. Selected data fields are available for editing.

Edit Ownership Category tab definition

Title	Description
Ownership Type Category Code	The code used to identify this ownership type category.
Ownership Type Category Description	Required. The familiar title of the ownership type category.
Active Indicator	Indicates whether this ownership type category code is active or inactive. Remove the check mark to deactivate.

Payment Terms Type

Select/Acquire

>

Vendor

>

•
Payment Terms Type
>

Payment Terms Type Lookup

>

Payment Terms Type

The Payment Terms Type document is used to establish codes that define a vendor's payment terms, including the number of days in which a payment is due and if a discount is available for prompt payment.

Document Layout

Payment Terms Type ?

Doc Nbr: 3253
Initiator: khuntle

Document Overview
▼ hide

Document Overview

* Description: <input style="width: 95%;" type="text"/>	Explanation: <input style="width: 95%;" type="text"/>
Org. Doc. #: <input style="width: 95%;" type="text"/>	

Edit Payment Terms Type
▼ hide

Old	New
Payment Terms Code: 00N05	Payment Terms Code: 00N05
Payment Terms Description: Net 5 Days	* Payment Terms Description: <input style="width: 95%;" type="text" value="Net 5 Days"/>
Payment Terms Percent: <input style="width: 95%;" type="text"/>	* Payment Terms Percent: <input style="width: 95%;" type="text"/>
Discount Due Number: <input style="width: 95%;" type="text"/>	* Discount Due Number: <input style="width: 95%;" type="text"/>
Discount Due Type Description: <input style="width: 95%;" type="text"/>	* Discount Due Type Description: <input type="radio"/> days <input type="radio"/>
Net Due Number: 5	* Net Due Number: <input style="width: 95%;" type="text" value="5"/>
Net Due Type Description: days	* Net Due Type Description: <input checked="" type="radio"/> days <input type="radio"/>
Active Indicator: Yes	Active Indicator: <input checked="" type="checkbox"/>

Notes and Attachments (0)
▶ show

Ad Hoc Recipients
▶ show

Route Log
▶ show

submit
save
blanket approve
close
cancel

The Payment Terms Type document includes the **Edit Payment Term Type** tab. The system automatically enters data into both the **Old** and **New** sections in this tab. Selected data fields are available for editing.

Edit Payment Term Type tab definition

Title	Description
Payment Terms Code	Required. Enter the code used to identify this payment terms type.
Payment Terms Description	Required. Enter the familiar title of the payment terms.
Payment Terms Percent	Required. Enter the percentage discount to be applied if the payment is made by the discount date.
Discount Due Number	Required. Enter a number that reflects either the number of days or the date (day of the month) by which payment must be made to qualify for the discount percentage.
Discount Due Type Description	Required. Select 'Days' or 'Date' to indicate whether the number entered in the Vendor Discount Due Number field is a number of days or a date (defined here as a specific day of the month).
Net Due Number	Required. Enter a number that reflects either the number of days or the date (day of the month) by which payment net is due.
Net Due Type Description	Required. Select 'Days' or 'Date' to indicate whether the number entered in the Vendor Net Due Number field is a number of days or a date (defined here as a specific day of the month).
Active Indicator	Optional. Select the check box if the payment term type is active. Clear the check box to inactivate the existing payment terms code.

Phone Type

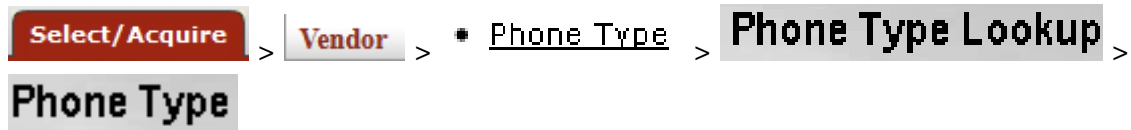

The Phone Type document is used to establish codes that identify various types of vendor phone or fax numbers. Sample phone types might be 'Phone,' 'Fax,' or 'Mobile.'

Document Layout

Phone Type ?		Doc Nbr: 3254
		Initiator: khuntle

Document Overview hide

* Description:	<input type="text"/>	Explanation:	<input type="text"/>
Org. Doc. #:	<input type="text"/>		

Edit Phone Type hide

Old		New	
Phone Type Code:	FX	Phone Type Code:	FX
Phone Type Description:	FAX	* Phone Type Description:	FAX
Active Indicator:	Yes	Active Indicator:	<input checked="" type="checkbox"/>

Notes and Attachments (0) show

Ad Hoc Recipients show

Route Log show

submit save blanket approve close cancel

The Phone Type document includes the **Edit Phone Type** tab. The system automatically enters data into both the **Old** and **New** sections in this tab. Selected data fields are available for editing.

Edit Phone Type tab definition

Title	Description
Phone Type Code	The code used to identify this phone type.
Phone Type Description	Required. The familiar title of the phone type.
Active Indicator	Indicates whether this phone type code is active or inactive. Remove the check mark to deactivate.

Shipping Payment Terms

Select/Acquire >
 Vendor >
 • Shipping Payment Terms >
 Shipping Payment Terms Lookup >
 Shipping Payment Terms

The Shipping Payment Terms document establishes codes that define the various terms that specify who is responsible for the payment of shipping charges for purchases from a vendor. Examples might include 'Institute Pays, Part of PO,' 'Paid by 3rd Party,' or 'Vendor Pays'.

Document Layout

Shipping Payment Terms ?

Doc Nbr: 3255
Initiator: khuntle

Document Overview ▼ hide

* Description: <input style="width: 90%;" type="text"/>	Explanation: <input style="width: 90%;" type="text"/>
Org. Doc. #: <input style="width: 80%;" type="text"/>	

Edit Shipping Payment Terms ▼ hide

Old	New
Shipping Payment Terms Code: AL	Shipping Payment Terms Code: AL
Shipping Payment Terms Description: VENDOR PAYS ("ALLOWED")	* Shipping Payment Terms Description: VENDOR PAYS ("ALLOWED")
Shipping Payment Terms Pay Indicator: Yes	Shipping Payment Terms Pay Indicator: <input checked="" type="checkbox"/>
Active Indicator: Yes	Active Indicator: <input checked="" type="checkbox"/>

Notes and Attachments (0) ▶ show

Ad Hoc Recipients ▶ show

Route Log ▶ show

submit save blanket approve close cancel

The Shipping Payment Terms document includes the **Edit Shipping Payment Terms** tab. The system automatically enters data into both the **Old** and **New** sections in this tab. Selected data fields are available for editing.

Edit Shipping Payment Terms tab definition

Title	Description
Shipping Payment Terms Code	The code used to identify the shipping payment terms.
Shipping Payment Terms Description	Required. The title of the shipping payment terms.
Shipping Payment Terms Pay Indicator	Indicates if it is permissible for the vendor to add shipping charges to an invoice. Remove check mark if shipping payment terms does not apply to payments.

Active Indicator

Indicates whether this shipping payment terms code is active or inactive. Remove the check mark to deactivate.

Shipping Special Conditions

Select/Acquire > Vendor > Shipping Special Conditions >
Shipping Special Conditions Lookup >
Shipping Special Conditions

The Shipping Special Conditions document establishes various categories of commodities that require special shipping considerations. Examples might include 'Express' or 'Insured'.

Document Layout

Shipping Special Conditions Doc Nbr: 3256

Initiator: khuntle

Document Overview hide

* Description: <input type="text"/>	Explanation: <input type="text"/>
Org. Doc. #: <input type="text"/>	

Edit Shipping Special Condition hide

Old	New
Shipping Special Condition Code: HA	Shipping Special Condition Code: HA
Shipping Special Condition Description: HAZMAT	* Shipping Special Condition Description: HAZMAT
Active Indicator: Yes	Active Indicator: <input checked="" type="checkbox"/>

Notes and Attachments (0) show

Ad Hoc Recipients show

Route Log show

submit save blanket approve close cancel

The Shipping Special Conditions document includes the **Edit Shipping Special Condition** tab. The system automatically enters data into both the **Old** and **New** sections in this tab. Selected data fields are available for editing.

Edit Shipping Special Condition tab definition

Title	Description
Shipping Special Condition Code	The code used to identify the shipping special condition.
Shipping Special Condition Description	Required. The familiar title of the shipping special condition.

Active Indicator

Indicates whether this shipping special condition code is active or inactive. Remove the check mark to deactivate.

Shipping Title

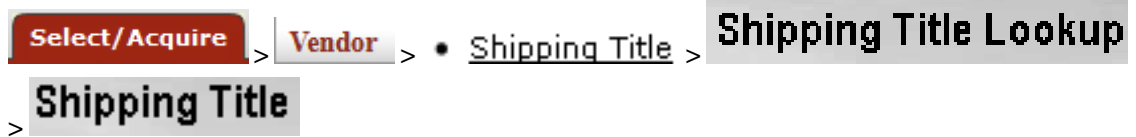

The Shipping Title document establishes the codes that define the point at which shipping titles are transferred and the institution takes possession of a shipment. Examples might include 'Destination,' 'Origin (Vendor Location),' or 'Customs-US Port.'

Document Layout

The screenshot shows a web interface for a 'Shipping Title' document. At the top right, there are fields for 'Doc Nbr: 3257' and 'Initiator: khuntle'. Below this is a 'Document Overview' tab with fields for '* Description:', 'Org. Doc. #:', and 'Explanation:'. The 'Edit Shipping Title' tab is active, showing a comparison between 'Old' and 'New' data. The 'Old' section has 'Shipping Title Code: CI', 'Shipping Title Description: CUSTOMS-INTERNATIONAL PORT', and 'Active Indicator: Yes'. The 'New' section has 'Shipping Title Code: CI', '* Shipping Title Description: CUSTOMS-IN...', and 'Active Indicator: '. Below the tabs are sections for 'Notes and Attachments (0)', 'Ad Hoc Recipients', and 'Route Log', each with a 'show' button. At the bottom, there are buttons for 'submit', 'save', 'blanket approve', 'close', and 'cancel'.

The Shipping Title document includes the **Edit Shipping Title** Tab. The system automatically enters data into both the **Old** and **New** sections in this tab. Selected data fields are available for editing.

Edit Shipping Title tab definition

Title	Description
Shipping Title Code	The code used to identify this vendor shipping title.
Shipping Title Description	Required. The familiar title of the vendor shipping title.
Active Indicator	Indicates whether this shipping title code is active or inactive. Remove the check mark to deactivate.

Supplier Diversity



Certain vendors may merit special consideration due to their size (small business), ownership (woman or minority owned), geographical location (local), or other factors. The Supplier Diversity document establishes the codes to identify the categories defined by the Small Business Administration.

Document Layout

Supplier Diversity ?		Doc Nbr: 3258
		Initiator: khuntle

Document Overview hide	
* Description: <input type="text"/>	Explanation: <input type="text"/>
Org. Doc. #: <input type="text"/>	

Edit Supplier Diversity hide	
Old	New
Supplier Diversity Code: DB	Supplier Diversity Code: DB
Supplier Diversity Description: DISABLED	* Supplier Diversity Description: DISABLED
Active Indicator: Yes	Active Indicator: <input checked="" type="checkbox"/>

Notes and Attachments (0) show
Ad Hoc Recipients show
Route Log show

The Supplier Diversity document includes the **Edit Supplier Diversity** tab. The system automatically enters data into both the **Old** and **New** sections in this tab. Selected data fields are available for editing.

Edit Supplier Diversity tab definition

Title	Description
Supplier Diversity Code	The code used to identify this supplier diversity type.
Supplier Diversity Description	Required. The title of the supplier diversity code.
Active Indicator	Indicates whether this supplier diversity code is active or inactive. Remove the check mark to deactivate.

Vendor Inactive Reason

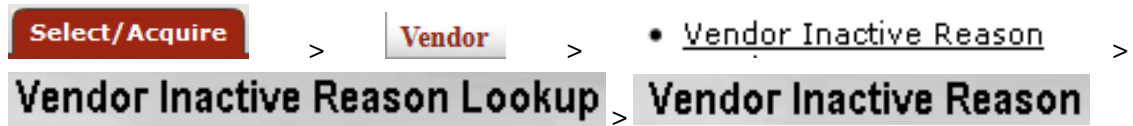

The Vendor Inactive Reason document establishes codes that indicate why a vendor is being inactivated in the system. Examples of codes might include 'Out of Business' or 'Merged.'

Document Layout

Vendor Inactive Reason ?		Doc Nbr: 3259
		Initiator: khuntle

Document Overview hide

Document Overview	
* Description:	<input type="text"/>
Org. Doc. #:	<input type="text"/>
Explanation:	
<input type="text"/>	

Edit Vendor Inactive Reason hide

Old		New	
Vendor Inactive Reason Code:	OB	Vendor Inactive Reason Code:	OB
Vendor Inactive Reason Description:	OUT OF BUSINESS	* Vendor Inactive Reason Description:	OUT OF BUS
Active Indicator:	Yes	Active Indicator:	<input checked="" type="checkbox"/>

Notes and Attachments (0) show

Ad Hoc Recipients show

Route Log show

submit save blanket approve close cancel

The Vendor Inactive Reason document includes the **Edit Vendor Inactive Reason** tab. The system automatically enters data into both the **Old** and **New** sections in this tab. Selected data fields are available for editing.

Edit Vendor Inactive Reason tab definition

Title	Description
Vendor Inactive Reason Code	The code used to identify this vendor inactive reason.
Vendor Inactive Reason Description	Required. The familiar title of the vendor inactive reason code.
Active Indicator	Indicates whether this vendor inactive reason code is active or inactive. Remove the check mark to deactivate.

Vendor Search Alias Type

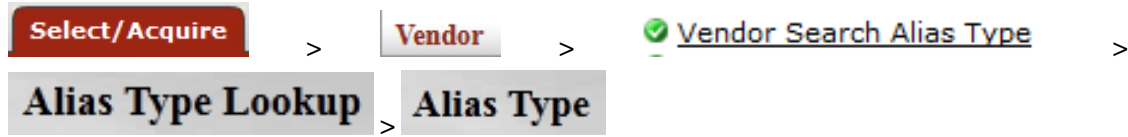

The Vendor Search Alias Type document establishes codes that indicate what type of vendor alias is used on the Vendor document. Examples of codes might include 'Abbreviation' or 'External Vendor Code.'

Document Layout

Alias Type ?	Doc Nbr:	5007	St
	Initiator:	ole-khuntley	Cre

Document Overview hide

* Description:	<input type="text"/>	Explanation:	<input type="text"/>
Organization Document Number:	<input type="text"/>		

Edit Alias Type hide

Old		New	
Alias Type:	Vendor Code	* Alias Type:	Vendor Code
Definition:	Library specific code for a vendor.	* Definition:	Library specific code for a v
Active Indicator:	Yes	Active Indicator:	<input checked="" type="checkbox"/>

Notes and Attachments (0) show

Ad Hoc Recipients show

Route Log show

The Vendor Alias Type document includes the **Edit Alias Type** tab. The system automatically enters data into both the **Old** and **New** sections in this tab. Selected data fields are available for editing.

Edit Alias Type tab definition

Title	Description
Alias Type	Required. The name of the alias type used to describe aliases.
Definition	Required. The description of the alias type.
Active Indicator	Indicates whether this alias type is active or inactive. Remove the check mark to deactivate.

Vendor Transmission Format

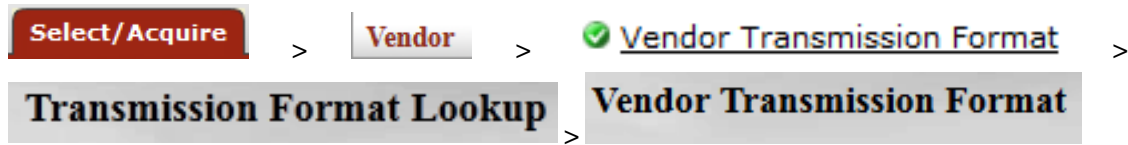

The Vendor Transmission Format document establishes the file formats that a vendor will use to receive purchase orders. Examples of formats might include 'EDI' or 'PDF'.

Document Layout

Vendor Transmission Format ? Backdoor Id admin is in use Doc Nbr: 5
Initiator: a

Document Overview hide

* Description: <input type="text"/>	Explanation: <input type="text"/>
Organization Document Number: <input type="text"/>	

Edit Vendor Transmission Format hide

Old	New
Vendor Transmission Format: EDI	* Vendor Transmission Format: <input type="text" value="EDI"/>
Active Indicator: Yes	Active Indicator: <input checked="" type="checkbox"/>

Notes and Attachments (0) show

Ad Hoc Recipients show

Route Log show

The Vendor Transmission Format document includes the **Edit Vendor Transmission Format** tab. The system automatically enters data into both the **Old** and **New** sections in this tab. Selected data fields are available for editing.

Edit Vendor Transmission Format tab definition

Title	Description
Vendor Transmission Format	Required. The name of the vendor transmission format.
Active Indicator	Indicates whether this vendor inactive reason code is active or inactive. Remove the check mark to deactivate.

Vendor Transmission Type

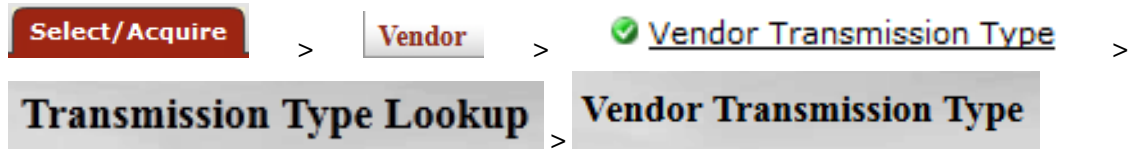

The Vendor Transmission Type document establishes how a purchase order will be sent to the vendor. Examples of transmission types might include 'FTP', 'Email', or 'Fax'.

Document Layout

Vendor Transmission Type ? Backdoor Id admin is in use Doc Nbr: 580
Initiator: adm

Document Overview hide

* Description: <input type="text"/>	Explanation: <input type="text"/>
Organization Document Number: <input type="text"/>	

Edit Transmission Type hide

Old	New
Transmission Type: FTP	* Transmission Type: FTP
Active Indicator: Yes	Active Indicator: <input checked="" type="checkbox"/>

Notes and Attachments (0) show

Ad Hoc Recipients show

Route Log show

The Vendor Transmission Type document includes the **Edit Vendor Transmission Type** tab. The system automatically enters data into both the **Old** and **New** sections in this tab. Selected data fields are available for editing.

Edit Vendor Transmission Type tab definition

Title	Description
Transmission Type	Required. The familiar name of the transmission type.
Active Indicator	Indicates whether this vendor inactive reason code is active or inactive. Remove the check mark to deactivate.

Vendor Type

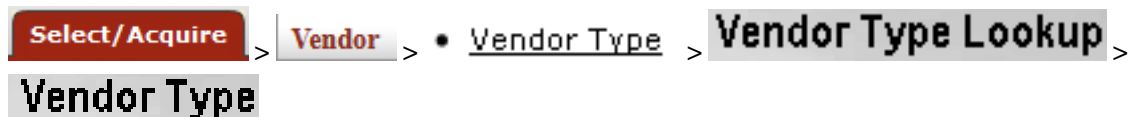

The Vendor Type document establishes codes to identify different types of vendors. Common types include 'Disbursement Voucher' and 'Purchase Order' vendors. The selection of vendors on specific documents can be restricted based on this type.

Document Layout

Vendor Type ?	Doc Nbr: 3260
	Initiator: khuntley

Document Overview ▼ hide

* Description: <input type="text"/>	Explanation: <input type="text"/>
Org. Doc. #: <input type="text"/>	

Edit Vendor Type ▼ hide

Old	New
Vendor Type Code: DV	Vendor Type Code: DV
Vendor Type Description: Disbursement Voucher	* Vendor Type Description: <input type="text" value="Disbursement Voucher"/>
Address Type Required: REMIT	* Address Type Required: <input type="text" value="REMIT"/> ▼ 🔍
Tax Number Required: Yes	Tax Number Required: <input checked="" type="checkbox"/>
Type Change Allowed: Yes	Type Change Allowed: <input checked="" type="checkbox"/>
Vendor Contract Allowed: No	Vendor Contract Allowed: <input type="checkbox"/>
Show Review Page: No	Show Review Page: <input type="checkbox"/>
Commodity Code Required: No	Commodity Code Required: <input type="checkbox"/>
Vendor Review Page Text: The new vendor, {0}, is about to be routed. The vendor's document ID is {1}. Please fax your W-9/W-8BEN documentation to 111-111-1111 and reference the Vendor document number on the form. For inquiries regarding vendor additions, changes or other vendor-related requests, please contact the workgroup at 222-222-2222 or email knoreceipt-l@indiana.edu. For general questions, please contact your local purchasing office. <table class="datatable" border="2"><tr><th>Campus</th><th>Hotline</th></tr><tr><td>Main</td><td>333-333-3333</td></tr><tr><td>East</td><td>444-444-4444</td></tr><tr><td>West</td><td>555-555-5555</td></tr></table> Press "yes" below if you understand these instructions. Press "no" if you wish to return to the document before routing.	Vendor Review Page Text: The new vendor, {0}, is about to be vendor's document ID is {1}. 8BEN documentation to 111-111-1111 Vendor document number on the fo inquiries regarding vendor additions
Active Indicator: Yes	Active Indicator: <input checked="" type="checkbox"/>

Notes and Attachments (0) ▶ show

Ad Hoc Recipients ▶ show

Route Log ▶ show

submit
save
blanket approve
close
cancel

The Vendor Type document includes the **Edit Vendor Type** tab. The system automatically enters data into both the **Old** and **New** sections in this tab. Selected data fields are available for editing.

Edit Vendor Type tab definition

Vendor Attribute Maintenance E-Docs

Title	Description
Vendor Type Code	The code used to identify this vendor type.
Vendor Type Description	Required. The familiar title of this vendor type.
Address Type Required	Required. The Address type that is required for this vendor type code. Existing address types may be retrieved from the list or from the lookup  .
Tax Number Required	Indicates if a vendor of this type is required to have a tax number. Remove this check mark if this tax number is not required.
Type Change Allowed	Indicates if a vendor of this type can be changed to another vendor type after creation. Remove this mark if this tax type change is not allowed.
Vendor Contract Allowed	Indicates whether a vendor of a specific type will allow contracts to be created and maintained. (For example, a Disbursement Voucher type would not allow contracts.)
Show Review Page	Indicates if the vendor review page text should be shown on the review page. Remove this check mark if not desired.
Commodity Code Required	Indicates that a commodity code is required. Remove this check mark if a commodity code is optional.
Vendor Review Page Text	Optional. In the last stage of adding a vendor, the system displays a review page where the user sees a snapshot of the information for the vendor. Text entered in this field will be displayed to the user on the review page and is for informational purposes only. For example, you might use it to explain what will happen to the Vendor document after it is submitted and what further actions need to be taken. Note Note: For security reasons, you must replace regular html <> brackets with square brackets [] in order to make vendor review page text display properly. Also, you must not use [table] or [a href]. [br] can be used but not [br/].
Active Indicator	Indicates whether this vendor type code is active or inactive. Remove the check mark to deactivate.

Chapter 12. Importing Records



On the Select/Acquire tab, the Import submenu provides access for users to import batch records and view load reports. Users may also import batch records from the **Batch Process** interface on the **Admin** tab.

Note

To learn more about the [Batch Process](#) interface, see the *OLE Guide to System Administration* on the [OLE Documentation Portal](#).

Staff Upload

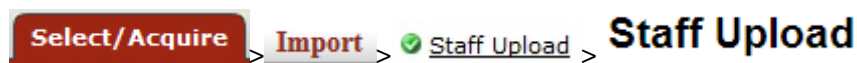

The Staff Upload interface allows users to import order process. In OLE 1.0, this requires that two files simultaneously be uploaded – an EDIFACT file and accompanying MARC file, which together represent the order and details about the item(s) ordered. The files should contain a representation of the same records (and the same number of records) based on the original preprocessing or conversion of sample vendor EOCR files. The import process will accept both the RAW file formats and the XML representation.

The process is driven by a 'profile' (chosen at upload time) which contains the logic needed to determine the actions that should be taken if a match (or no match) is found and includes values needed during the creation of the bib, purchase order and instance records.

Vendor EOCRs

Presently, OLE 1.0 provides sample EDIFACT order messages and matching MARC bibliographic files to test import of firm, fixed orders. Future versions of Import will also be coded in new OLE releases to include other order types, bibliographic overlay, and invoices.

To access the order files to test-drive Import, sample order files that validate to our current coded schema are found at the OLE demo Web site (OLE-EOCR-master.zip):

<https://wiki.kuali.org/display/OLE/OLE+Data+Import+Templates>

Note

If technical users prefer to modify some of your own library records to match the schema, and upload those into the DEMO environment, we request that you limit your file loads at this time to **no more** than 10-20 documents or file pairs. This is out of courtesy to other users navigating the demo system, and to maintain overall performance.

One example, zipped files from Duke University, is available on the wiki.

Process Overview

The **Staff Upload** interface is available from the **Main Menu**, located under the **Import** sub tab.

[Home](#) » [Staff Upload](#) »

Staff Upload

* **Marc File Upload:** No file chosen

* **EDI File Upload:** No file chosen

* **Load Profile:** ▼

Description:

1. Receive files of bibliographic and order data from the vendor.

Note

If not already done by vendor, you will need to pre-process files into XML MARC and EDI files.

2. From the **Staff Upload** screen, select a MARC and an EDI file to upload and optionally provide a description.

Note

If you attempt to import a pair of EDI and MARC files that do not match the import schema you will get an error message.

3. Choose the **Load Profile** from the drop down menu.

Note

For testing, choose **YBP**.

- 4.



Click the button to process the file.

Note: Provided sample files were created to match import rules and actions which make up a sample import profile. OLE demo users can use their own files as well if they can be modified to match the schema and do not exceed the recommended maximum file size of 10 EOCRs.

5. OLE will provide a message letting you know if the load was successful or not.

6.



Click on  to view load reports.

Note

For more information about Load Reports, see [below](#).

Business Rules

- Users must upload paired files – either MARC and EDI or MARCXML and EDIFACT-XML
- For successful loads, Purchase Orders and Bibliographic records with linked Instance (Holding and Item) are created.
- Extra records will be logged in the Load Failure Details of the Load Report.
- Any and all load error conditions will be included in the load report as attachment files.

Routing

- The OLE_Load role will receive an FYI if the load was successful.
- The OLE_Load role will receive an acknowledgement (approval) if not.

Load Reports



Load Reports provide users with access to information about the loads performed within OLE. The reports give information about how many successes and/or fails were counted and links to the purchase orders and bibliographic records that may have been created.

Getting Started

OLE offers a customized document search related to load reports. The search screen contains the standard search fields along with special fields that are unique to this type of e-doc. Click the Document Id to open a Load Report.

Note

For information about performing a search for one or more load reports, see [Performing Acquisition Searches](#) on the *OLE E-Doc Fundamentals* wiki page.

Document Layout

The following displays an example of a successful load.

Acquisitions Batch Upload ?	Doc Nbr: 3535	Statu
	Initiator: ole-khuntley	Date Of Loa
	Load Id: 1002	

Document Overview ▼ hide

Document Overview	
* Description: YBP_Firm_Ingest_kyh_021413	Explanation:
Organization Document Number:	

Load Summary ▼ hide

Name Of Load Profile:	YBP
User ID:	ole-khuntley
Counts :	TOTAL: 6 -- SUCCESS: 6 -- FAILED: 0
Name Of File:	ole37.mrc , ole37.edi
No. Of POs Created:	6
No. Of Bibs Created:	6
List Of All POs:	List Of All POs
List Of All Bibs:	List Of All Bibs
Description:	
Date Of Load:	02/14/2013 04:11 PM

Notes and Attachments (0) ▶ show

Ad Hoc Recipients ▶ show

Route Log ▶ show

submit save reload blanket approve close cancel

If there were problems with the load, an additional tab, **Load Failure Details** will display the errors and the files will be available to you in the **Notes and Attachments** tab.

The following displays an example of a failed load.

Acquisitions Batch Upload	Doc Nbr:	3543	
	Initiator:	ole-khuntley	Date
	Load Id:	1003	

Document Overview ▼ hide

* Description:	<input type="text" value="YBP_Firm_Ingest_kyh_021413"/>	Explanation:	
Organization Document Number:	<input type="text"/>		

Load Summary ▼ hide

Name Of Load Profile:	YBP
User ID:	ole-khuntley
Counts :	TOTAL: 6 -- SUCCESS: 0 -- FAILED: 6
Name Of File:	ole37dups.mrc , ole37.edi
No. Of POs Created:	0
No. Of Bibs Created:	0
Description:	
Date Of Load:	02/14/2013 04:13 PM

Load Failure Details ▼ hide

ISBN:	TITLE:	Error Id:
9781845192457	SUFFERING SAINTS : JANSENISTS AND CONVULSIONNAIRES IN FRANCE, 1640-1799.	ISBN_DUP_FOUND
9781933002408	VICTIMS RETURN : SURVIVORS OF THE GULAG AFTER STALIN.	ISBN_DUP_FOUND

Notes and Attachments (2) ▼ hide

	Posted Timestamp	Author	* Note Text	Attached File
add:			<input type="text"/>	<input type="text" value=""/> <small>CANCEL</small>
1	02/14/2013 04:13 PM	HUNTLEY, KEISHA Y	Failure Edi File	1003_edi_err.xml (8 KB, application/octet-stream)
2	02/14/2013 04:13 PM	HUNTLEY, KEISHA Y	Failure Bib File	1003_bib_err.xml (2 KB, application/octet-stream)

Ad Hoc Recipients ▶ show

Route Log ▶ show

submit save reload blanket approve close cancel

Load Summary Tab

Load Summary tab definition

Title	Description
Name of Load Profile	Reports the name of the Load Profile used during the import process
User ID	Reports who was logged in and performed the import
Counts	Reports the total amount of records imported along with the successes and fails

Importing Records

Name of File	Lists the MARC and EDI files processed during the import
No of POs Created	Reports the amount of Purchase Orders created
No of Bibs Created	Reports the amount of Bibliographic Records created
List of All POs	Links to the list of the Purchase Orders created
List of All Bibs	Links to the list of the Bibliographic Records created
Description	Presents the description that was input on the Staff Upload page
Date of Load	System generated time stamp of when the import occurred

Load Failure Details

The import profile guides the processing of records during the import process. If the logic contained in the import profile reaches an exception point based on the match logic, the record will fail to be processed. OLE will display details about each failed record detected in the file under the tab **Load Failure Details**.

Load Failure Details ▼ hide		
ISBN:	TITLE:	Error Id:
9781845192457	SUFFERING SAINTS : JANSENISTS AND CONVULSIONNAIRES IN FRANCE, 1640-1799.	ISBN_DUP_FOUND
9781933002408	VICTIMS RETURN : SURVIVORS OF THE GULAG AFTER STALIN.	ISBN_DUP_FOUND

Load Failure Details tab definition

Title	Description
ISBN	The ISBN number associated with the error record.
Title	The title of the record associated with the error record.
Error Id	Gives a description of the error that occurred.



Notes and Attachments Tab

If any of the files have failed during the import process, the files will be attached under the **Notes and Attachments** tab.

Notes and Attachments (1) ▼ hide				
Notes and Attachments				
	Posted Timestamp	Author	* Note Text	Attached File
add:				<input type="text"/> CANCEL
1	01/08/2013 10:19 AM	HUNTLEY, KEISHA Y	Extra Edi Records File	 1014_edi_err.xml (3 KB, application/octet-stream)

Notes and Attachments tab definition

Title	Description
Posted Timestamp	Display only. The date and time the error record was loaded.

Author	Display only. The name of the person who loaded the record into OLE
Note Text	A brief description as to why the file could not be imported.
Attached File	 Click  to download the file. Edit and re-load as appropriate. Note You will need to use the Staff Upload interface to re-load records. Adding new files as a Notes and Attachments file will not load items into the DocStore.

Process Overview

1. From the **Load Summary Lookup** page, optionally enter details about the file import and click the **search** button. The system displays the search results in the same window or browser tab, below the search fields.

Note

To learn more about searching, see [Searching OLE](#) on the *OLE E-Docs fundamentals* wiki page.

2. Select the appropriate document listed under the **Document Id** to open the **Acquisitions Batch Upload**.

The **Load Summary** contains details about each load.

3. To view the purchase order, click the link **List of All POs** on the **Load Summary** tab. You may view and edit purchase orders from this list.

Note

To learn more about purchase orders, see [above](#).

4. To view the bibliographic records, click the link **List of All Bibs** on the **Load Summary** tab. You may view and edit the bibliographic records from this list.

Note

To learn more about bibliographic records, see the Editor section in the *Guide to Describe – DocStore and Editors*. This and other OLE user guides are available for download from the [OLE Documentation Portal](#).

5. Review the **Notes and Attachments** tab for failed file uploads.

6. Review the **Route Log** tab.

Note

For more information about the Route Log, see [Route Log](#) on the *OLE Workflow Overview and Key Concepts* wiki page.

Chapter 13. Purchasing/Accounts Payable Maintenance E-Docs

Purchasing/Accounts Payable

- ✔ [Billing Address](#)
- ✔ [Carrier](#)
- ✔ [Category](#)
- ✔ [Delivery Required Date Reason](#)
- ✔ [Electronic Invoice Item Mapping](#)
- ✔ [Exception Type](#)
- ✔ [Format](#)
- ✔ [Funding Source](#)
- ✔ [Invoice Sub Type](#)
- ✔ [Invoice Type](#)
- ✔ [Item Price Source](#)
- ✔ [Item Reason Added](#)
- ✔ [Item Type](#)
- ✔ [Method of PO Transmission](#)
- ✔ [Negative Payment Request Approval Limit](#)
- ✔ [Note Type](#)
- ✔ [Organization Parameter](#)
- ✔ [Order Type](#)
- ✔ [Payment Method](#)
- ✔ [Payment Request Auto Approve Exclusions](#)
- ✔ [Purchase Order Contract Language](#)
- ✔ [Purchase Order Item Status](#)
- ✔ [Purchase Order Quote Language](#)
- ✔ [Purchase Order Quote List](#)
- ✔ [Purchase Order Quote Status](#)
- ✔ [Purchase Order Vendor Choice](#)
- ✔ [Receiving Address](#)
- ✔ [Receiving Threshold](#)
- ✔ [Recurring Payment Frequency](#)
- ✔ [Recurring Payment Type](#)
- ✔ [Request Source Type](#)
- ✔ [Requisition Source](#)
- ✔ [Sensitive Data](#)
- ✔ [Vendor Stipulation](#)
- ✔ [Licensing Requirement](#)
- ✔ [Authentication Type](#)
- ✔ [Access Location](#)
- ✔ [E-Resource Status](#)
- ✔ [Package Type](#)
- ✔ [Package Scope](#)
- ✔ [Material Type](#)
- ✔ [Access Type](#)
- ✔ [Content Type](#)
- ✔ [Payment Type](#)
- ✔ [Request Priority](#)
- ⚠ [General Ledger Entry](#)
- ⚠ [Available Balances](#)
- ✔ [Globally Protected Field](#)

Select/Acquire >

Order, Paying, Receiving, and E-Resource maintenance e-docs as well as general ledger entry and available balances lookups are available via the Purchasing/Accounts Payable submenu on the **Select/Acquire** menu tab.

Billing Address



The Billing Address document defines the various addresses to which vendors should send invoices. Addresses are specific to a campus but a campus can have multiple billing addresses.

Document Layout

Billing Address ?		Doc Nbr: 3264
		Initiator: khuntley

Document Overview ▼ hide

Document Overview

* Description: <input type="text"/>	Explanation: <input type="text"/>
Org. Doc. #: <input type="text"/>	

Edit Billing Address ▼ hide

Old	New
Billing Campus Code: BL - BLOOMINGTON	Billing Campus Code: BL - BLOOMINGTON
Billing Name: THE UNIVERSITY	* Billing Name: THE UNIVERSITY
Billing Line 1 Address: ACCOUNTS PAYABLE	* Billing Line 1 Address: ACCOUNTS PAYABLE
Billing Line 2 Address: P.O. BOX 4095	Billing Line 2 Address: P.O. BOX 4095
Billing City Name: BUTTER NUT	* Billing City Name: BUTTER NUT
Billing State Code: SOUTH CAROLINA	Billing State Code: SOUTH CAROLINA
Billing Postal Code: 47402	Billing Postal Code: 47402 <input type="text"/>
Billing Country Code: UNITED STATES	* Billing Country Code: UNITED STATES
Billing Phone Number: 342-456-2398	* Billing Phone Number: 342-456-2398
Active Indicator: Yes	Active Indicator: <input checked="" type="checkbox"/>

Notes and Attachments (0) ▶ show

Ad Hoc Recipients ▶ show

Route Log ▶ show

submit
save
blanket approve
close
cancel

The Billing Address document includes the **Edit Billing Address** tab. The system automatically enters data into both the **Old** and **New** sections in this tab. Selected data fields are available for editing.

Edit Billing Address tab definition

Title	Description
Billing Campus Code	The campus code associated with this billing address.
Billing Name	Required. The familiar title of the billing address.

Purchasing/Accounts
Payable Maintenance E-Docs

Billing Line 1 Address	Required. The first line of the address information for this billing address.
Billing Line 2 Address	Optional. The second line of the address information for this billing address.
Billing City Name	Required. The city name associated with this billing address.
Billing State Code	The state associated with this billing address. Existing state codes may be retrieved from the list.
Billing Postal Code	The postal code associated with this billing address.
Billing Country Code	Required. The country associated with this billing address. Existing country codes may be retrieved from the list.
Billing Phone Number	Required. The phone number, including area code for this billing address. (Formatted: xxx-xxx-xxxx)
Active Indicator	Indicates whether this billing address is active or inactive. Remove the check mark to deactivate.

Carrier

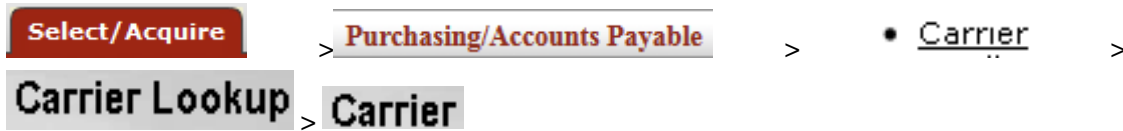

The Carrier document defines the possible freight carriers and shipping companies assigned to deliver goods.

Document Layout

Carrier		Doc Nbr: 3267
		Initiator: khuntle

Document Overview ▼ hide

Document Overview

* Description: <input type="text"/>	Explanation: <input type="text"/>
Org. Doc. #: <input type="text"/>	

Edit Carrier ▼ hide

Old	New
Carrier Code: ABF	Carrier Code: ABF
Carrier Description: ABF FREIGHT SYSTEMS	* Carrier Description: ABF FREIGHT
Active Indicator: Yes	Active Indicator: <input checked="" type="checkbox"/>

Notes and Attachments (0) ▶ show

Ad Hoc Recipients ▶ show

Route Log ▶ show

submit save blanket approve close cancel

The Carrier document includes the **Edit Carrier** tab. The system automatically enters data into both the **Old** and **New** sections in this tab. Selected data fields are available for editing.

Edit Carrier tab definition

Title	Description
Carrier Code	A unique code to identify a particular carrier.
Carrier Description	Required. A description or name of the carrier.
Active Indicator	Indicates whether this carrier code is active or inactive. Remove the check mark to deactivate the code.

Category

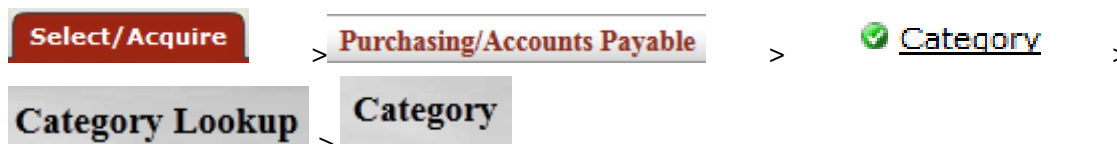

The Category document defines the possible groupings used to manage the selection and acquisition of titles on requisitions and purchase orders.

Document Layout

Category ?

Doc Nbr: 4100
Initiator: ole-khu

Document Overview hide

Document Overview

* Description:	<input type="text"/>	Explanation:	<input type="text"/>
Organization Document Number:	<input type="text"/>		

Edit Category hide

Old		New	
Category:	Area Studies	* Category:	Area Studies
Active Indicator:	Yes	Active Indicator:	<input checked="" type="checkbox"/>

Notes and Attachments (0) show

Ad Hoc Recipients show

Route Log show

The Category document includes the **Edit Category** tab. The system automatically enters data into both the **Old** and **New** sections in this tab. Selected data fields are available for editing.

Edit Category tab definition

Title	Description
Category	Required. A description or name of the category.
Active Indicator	Indicates whether this category is active or inactive. Remove the check mark to deactivate the code.

Delivery Required Date Reason

Select/Acquire > **Purchasing/Accounts Payable** >

- Delivery Required Date Reason >

Delivery Required Date Reason Lookup >

Delivery Required Date Reason

The Delivery Required Date Reason document defines the reasons for requiring the delivery date in the Purchasing/AP module. Examples might include types of 'Must Receive' or 'Estimated Date.'

Document Layout

Delivery Required Date Reason ?		Doc Nbr: 3269
		Initiator: khuntley

Document Overview ▼ hide

Document Overview	
* Description: <input type="text"/>	Explanation: <input type="text"/>
Org. Doc. #: <input type="text"/>	

Edit Delivery Required Date Reason ▼ hide

Old		New	
Delivery Required Date Reason Code:	BUY	Delivery Required Date Reason Code:	BUY
Delivery Required Date Reason Description:	ESTIMATED DATE	* Delivery Required Date Reason Description:	ESTIMATED DA
Active Indicator:	Yes	Active Indicator:	<input checked="" type="checkbox"/>

Notes and Attachments (0) ▶ show

Ad Hoc Recipients ▶ show

Route Log ▶ show

submit save blanket approve close cancel

The Delivery Required Date Reason document includes the **Edit Delivery Required Date Reason** tab. The system automatically enters data into both the **Old** and **New** sections in this tab. Selected data fields are available for editing.

Edit Delivery Required Date Reason tab definition

Title	Description
Delivery Required Date Reason Code	The code to identify this delivery required date reason from the Reason Code list.
Delivery Required Date Reason Description	Required. The familiar title for this delivery required date reason.

Active Indicator

Indicates whether this delivery required date reason code is active or inactive. Remove the check mark to deactivate this code.

Electronic Invoice Item Mapping

Select/Acquire > **Purchasing/Accounts Payable** >

- **Electronic Invoice Item Mapping** >

Electronic Invoice Item Mapping Code Lookup >

Electronic Invoice Item Mapping

The Electronic Invoice Item Mapping document specifies unique mapping of additional items per vendor if the business need exists. OLE follows cXML standards in that five item types are defined (Item, Special Handling, Shipping, and Discount). Each vendor invoice is mapped according to the Electronic Invoice Item Mapping Code table via the electronic invoicing batch job.

Document Layout

The Electronic Invoice Item Mapping document includes the **Edit Electronic Invoice Item Mapping** tab.

Electronic Invoice Item Mapping ?	Doc Nbr: 3270	Status:
	Initiator: khuntley	Created:

expand

Document Overview ▼ hide

Document Overview

* Description: <input type="text"/>	Explanation: <input type="text"/>
Org. Doc. #: <input type="text"/>	

Edit Electronic Invoice Item Mapping ▼ hide

New

* Invoice Item Type Code: <input type="text"/>	
Item Type Code: <input type="text"/>	
Vendor Header Identifier: <input type="text"/>	
Vendor Detail Identifier: <input type="text"/>	

Notes and Attachments (0) ▶ show

Ad Hoc Recipients ▶ show

Route Log ▶ show

Edit Electronic Invoice Item Mapping tab definition

Title	Description
Invoice Item Type Code	Required. The field name on the vendor invoice to compare the value.
Item Type Code	The item code in OLE to which the invoice item type code will map to. Existing item type codes may be retrieved from the lookup

Vendor Header Identifier	Optional. The segment of the vendor number that precedes the dash. For example, for vendor number 1000-0, the vendor header identifier is 1000.
Vendor Detail Identifier	Required if the Vendor Header Identifier field is completed. The segment of the vendor number that follows the dash. For example, for vendor number 1000-0, the detail identifier is 0.

Exception Type

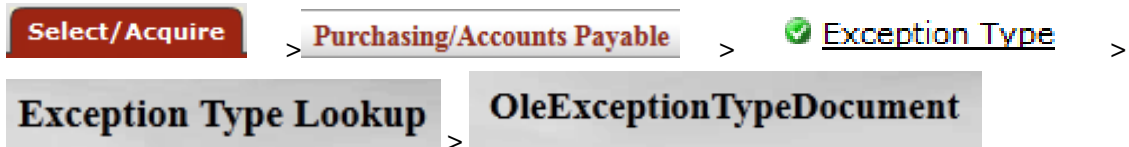

The Exception Type identifies types of exceptions when receiving resources. Some exceptions are received damaged, received the wrong edition, etc.

Document Layout

The screenshot shows the 'OleExceptionTypeDocument' web form. At the top right, it displays 'Doc Nbr: 4098' and 'Initiator: ole-kh'. The main content area is divided into several tabs: 'Document Overview', 'Edit Exception Type', 'Notes and Attachments (0)', 'Ad Hoc Recipients', and 'Route Log'. The 'Document Overview' tab is active, showing fields for 'Description', 'Organization Document Number', and 'Explanation'. The 'Edit Exception Type' tab is also visible, showing a comparison between 'Old' and 'New' values for 'Exception Type' (both 'Received-damaged') and 'Active Indicator' (Old: 'Yes', New: checked checkbox). At the bottom, there are buttons for 'submit', 'save', 'blanket approve', 'close', and 'cancel'.

The Exception Type document includes the **Edit Exception Type** tab. The system automatically enters data into both the **Old** and **New** sections in this tab. Selected data fields are available for editing.

Edit Exception Type tab definition

Title	Description
Exception Type	Required. A description or name of the exception type.
Active Indicator	Indicates whether this exception type is active or inactive. Remove the check mark to deactivate this type.

Format

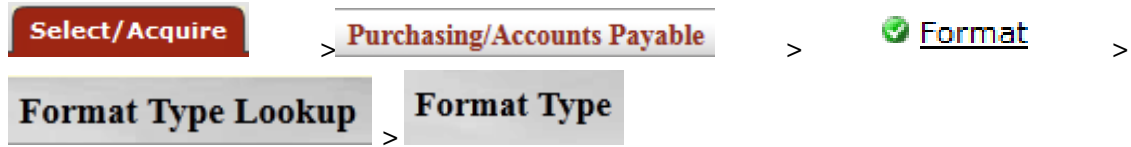

The Format Type is the type of material of a title, e.g., a printed book, e-book, DVD, map, serial, CD, kit, etc.

Document Layout

Format Type ?	Doc Nbr: 4099
	Initiator: ole-khu

Document Overview hide

Document Overview

* Description:	<input type="text"/>	Explanation:	<input type="text"/>
Organization Document Number:	<input type="text"/>		

Edit Format Type hide

Old	New
Format Type: E-Book	* Format Type: E-Book
Active Indicator: Yes	Active Indicator: <input checked="" type="checkbox"/>

Notes and Attachments (0) show

Ad Hoc Recipients show

Route Log show

submit save blanket approve close cancel

The Format Type document includes the **Edit Format Type** tab. The system automatically enters data into both the **Old** and **New** sections in this tab. Selected data fields are available for editing.

Edit Format Type tab definition

Title	Description
Format Type	Required. A description or name of the format type.
Active Indicator	Indicates whether this format type is active or inactive. Remove the check mark to deactivate this type.

Funding Source



The Funding Source document defines the different fund sources that are available to choose from for purchasing documents.

Document Layout

Funding Source ?

Doc Nbr: 3271
Initiator: khuntle

Document Overview
▼ hide

Document Overview

* Description: <input style="width: 90%;" type="text"/>	Explanation: <input style="width: 90%;" type="text"/>
Org. Doc. #: <input style="width: 80%;" type="text"/>	

Edit Funding Source
▼ hide

Old	New
Funding Source Code: INST	Funding Source Code: INST
Funding Source Description: INSTITUTION ACCOUNT	* Funding Source Description: <input style="width: 90%;" type="text" value="INSTITUTION"/>
Active Indicator: Yes	Active Indicator: <input checked="" type="checkbox"/>

Notes and Attachments (0) ▶ show

Ad Hoc Recipients ▶ show

Route Log ▶ show

submit
save
blanket approve
close
cancel

The Funding Source document includes the **Edit Funding Source** tab. The system automatically enters data into both the **Old** and **New** sections in this tab. Selected data fields are available for editing.

Edit Funding Source tab definition

Title	Description
Funding Source Code	The code to identify this funding source.
Funding Source Description	Required. The familiar title of this funding source.
Active Indicator	Indicates whether this funding source code is active or inactive. Remove the check mark to deactivate this code.

Invoice Sub Type

Select/Acquire

>

Purchasing/Accounts Payable

>

✔ Invoice Sub Type

>

Invoice Sub Type Lookup

>

OLE Invoice SubType Document

The Invoice Sub Type document identifies the subtype of an invoice on a payment request and may impact workflow.

Document Layout

OLE Invoice SubType Document ?		Doc Nbr: 4097
		Initiator: ole-khuntlev

Document Overview hide

* Description:	<input type="text"/>	Explanation:	<input type="text"/>
Organization Document Number:	<input type="text"/>		

Edit Invoice SubType hide

Old		New	
Invoice SubType:	Regular	* Invoice SubType:	Regular
Invoice SubType Description:	Regular	Invoice SubType Description:	Regular
Active Indicator:	Yes	Active Indicator:	<input checked="" type="checkbox"/>

Notes and Attachments (0) show

Ad Hoc Recipients show

Route Log show

submit save blanket approve close cancel

The Invoice Sub Type document includes the **Edit Invoice Sub Type** tab. The system automatically enters data into both the **Old** and **New** sections in this tab. Selected data fields are available for editing.

Edit Invoice Type tab definition

Title	Description
Invoice Sub Type	Required. A description or name of the invoice subtype.
Invoice Sub Type Description	A description or name of the invoice subtype.
Active Indicator	Indicates whether this invoice subtype is active or inactive. Remove the check mark to deactivate this subtype.

Invoice Type

Select/Acquire > Purchasing/Accounts Payable > Invoice Type >
Invoice Type Lookup > OLE Invoice Type Document

The Invoice Type document identifies the type of invoice on a payment request and may impact workflow.

Document Layout

OLE Invoice Type Document ?		Doc Nbr: 4096
		Initiator: ole-khuntley

Document Overview hide

* Description:	<input type="text"/>	Explanation:	<input type="text"/>
Organization Document Number:	<input type="text"/>		

Edit Invoice Type hide

Old		New	
Invoice Type:	Standard	* Invoice Type:	Standard
Invoice Type Description:	Standard	Invoice Type Description:	Standard
Active Indicator:	Yes	Active Indicator:	<input checked="" type="checkbox"/>

Notes and Attachments (0) show

Ad Hoc Recipients show

Route Log show

submit save blanket approve close cancel

The Invoice Type document includes the **Edit Invoice Type** tab. The system automatically enters data into both the **Old** and **New** sections in this tab. Selected data fields are available for editing.

Edit Invoice Type tab definition

Title	Description
Invoice Type	Required. A description or name of the invoice type.
Invoice Type Description	A description or name of the invoice type.
Active Indicator	Indicates whether this invoice type is active or inactive. Remove the check mark to deactivate this type.

Item Price Source

Select/Acquire > Purchasing/Accounts Payable > Item Price Source >

Item Price Source Lookup > Item Price Source

The Item Price Source document identifies the source of the item price for titles on requisitions and purchase orders.

Document Layout

Item Price Source ?		Doc Nbr: 4095
		Initiator: ole-khur

Document Overview ▼ hide

* Description: <input type="text"/>	Explanation: <input type="text"/>
Organization Document Number: <input type="text"/>	

Edit Item Price Source ▼ hide

Old	New
Item Price Source: Vendor	* Item Price Source: Vendor
Active Indicator: Yes	Active Indicator: <input checked="" type="checkbox"/>

Notes and Attachments (0) ▶ show

Ad Hoc Recipients ▶ show

Route Log ▶ show

submit save blanket approve close cancel

The Item Price Source document includes the **Edit Item Price Source** tab. The system automatically enters data into both the **Old** and **New** sections in this tab. Selected data fields are available for editing.

Edit Item Price Source tab definition

Title	Description
Item Price Source	Required. A description or name of the item price source.
Active Indicator	Indicates whether this item price source is active or inactive. Remove the check mark to deactivate this source.

Item Reason Added

Select/Acquire >
 Purchasing/Accounts Payable >
 * Item Reason Added >
 Item Reason Added Lookup >
 Item Reason Added

The Item Reason Added document defines possible options to list on a receiving ticket as reasons for why an item was received that was not on the original purchase order.

Document Layout

Item Reason Added ?		Doc Nbr: 3272
		Initiator: khuntle

Document Overview hide

Document Overview

* Description:	<input type="text"/>	Explanation:	<input type="text"/>
Org. Doc. #:	<input type="text"/>		

Edit Reason Added hide

Old		New	
Item Reason Added Code:	NTOR	Item Reason Added Code:	NTOR
Item Reason Added Description:	Not on Order	* Item Reason Added Description:	<input type="text" value="Not on Order"/>
Active:	Yes	Active:	<input checked="" type="checkbox"/>

Notes and Attachments (0) show

Ad Hoc Recipients show

Route Log show

submit save blanket approve close cancel

The Item Reason Added document includes the **Edit Reason Added** tab. The system automatically enters data into both the **Old** and **New** sections in this tab. Selected data fields are available for editing.

Edit Reason Added tab definition

Title	Description
Item Reason Added Code	A unique code to identify a particular reason added.
Item Reason Added Description	Required. A description of the reason added.
Active	Indicates whether this item reason code is active or inactive. Remove the check mark to deactivate this code.

Item Type

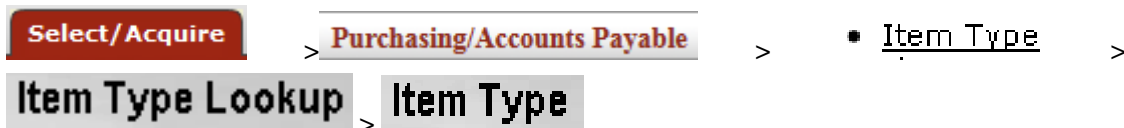

The Item Type document defines the different descriptive categories that can be applied to requisition or purchase order line items. Examples might include Item, Service, State Tax, or Shipping and Handling.

Document Layout

Item Type ?		Doc Nbr: 3273
		Initiator: khuntle

Document Overview hide

* Description:	<input type="text"/>	Explanation:	<input type="text"/>
Org. Doc. #:	<input type="text"/>		

Edit Item Type hide

Old		New	
Item Type Code:	FDTX	Item Type Code:	FDTX
Item Type Description:	Federal Tax	* Item Type Description:	Federal Tax
Quantity Based General Ledger Indicator:	No	Quantity Based General Ledger Indicator:	<input type="checkbox"/>
Additional Charge Indicator:	Yes	Additional Charge Indicator:	<input checked="" type="checkbox"/>
Taxable Indicator:	Yes	Taxable Indicator:	<input checked="" type="checkbox"/>
Active Indicator:	Yes	Active Indicator:	<input checked="" type="checkbox"/>

Notes and Attachments (0) show

Ad Hoc Recipients show

Route Log show

submit save blanket approve close cancel

The document includes the **Edit Item Type** tab. The system automatically enters data into both the **Old** and **New** sections in this tab. Selected data fields are available for editing.

Edit Item Type tab definition

Title	Description
Item Type Code	The code to identify this item type.
Item Type Description	Required. The familiar title of this item type.
Quantity Based General Ledger Indicator	Required. An indicator that the Dollar Total is calculated from the Item quantity times dollar amount rather than a reference to a dollar amount.
Additional Charge Indicator	Required. Used when additional charges are allowed.
Taxable Indicator	Used when the item is taxable.
Active Indicator	Indicates whether this item type code is active or inactive. Remove the check mark to deactivate this code.

Method of PO Transmission

Select/Acquire > **Purchasing/Accounts Payable** >

- Method of PO Transmission >

Method of PO Transmission Lookup

>

Method of PO Transmission

The Purchase Order Transmission Method document defines methods for transmitting purchase orders to vendors.

Document Layout

Method of PO Transmission ?		Doc Nbr: 3275
		Initiator: khuntle

Document Overview hide

* Description:	<input type="text"/>	Explanation:	<input type="text"/>
Org. Doc. #:	<input type="text"/>		

Edit Method of PO Transmission hide

Old		New	
Method of PO Transmission Code:	NOPR	Method of PO Transmission Code:	NOPR
Method of PO Transmission Description:	NO PRINT	* Method of PO Transmission Description:	NO PRINT
Active Indicator:	Yes	Active Indicator:	<input checked="" type="checkbox"/>

Notes and Attachments (0) show

Ad Hoc Recipients show

Route Log show

submit save blanket approve close cancel

The Purchase Order Transmission Method document includes the **Edit PO Transmission Method** tab. The system automatically enters data into both the **Old** and **New** sections in this tab. Selected data fields are available for editing.

Edit PO Transmission Method tab definition

Title	Description
Method of PO Transmission Code	The code to identify this purchase order transmission method.
Method of PO Transmission Description	Required. The familiar title of this purchase order transmission method.
Active Indicator	Indicates whether this method of PO transmission code is active or inactive. Remove the check mark to deactivate this code.

Negative Payment Request Approval Limit

Select/Acquire	>	Purchasing/Accounts Payable	>
• <u>Negative Payment Request Approval Limit</u>			>

Negative Payment Request Approval Limit Lookup

>

Negative Payment Request Approval Limit

The Negative Payment Request Approval Limit document identifies an account or organization and specifies a dollar amount limit to exclude the payment request from automated approvals. Payment requests referencing this account or organization and exceeding this dollar amount are excluded from automated approval.

Document Layout

Negative Payment Request Approval Limit ?		Doc Nbr: 3276
		Initiator: khuntle

Document Overview ▼ hide

Document Overview

* Description: <input type="text"/>	Explanation: <input type="text"/>
Org. Doc. #: <input type="text"/>	

Edit Negative PREQ Approval Limit ▼ hide

New

* Chart Code: <input type="text"/> 🔍
Organization Code: <input type="text"/> 🔍
Account Number: <input type="text"/> 🔍
* Negative Payment Request Approval Limit Amount: <input type="text"/>
* Active Indicator: <input checked="" type="checkbox"/>

Notes and Attachments (0) ▶ show

Ad Hoc Recipients ▶ show

Route Log ▶ show

submit save blanket approve close cancel

The Negative Payment Request Approval Limit document includes the **Edit Negative PREQ Approval Limit** tab.

Edit Auto Approve Exclude tab definition

Title	Description
Chart of Accounts Code	Required. The Chart of Accounts code associated with the account to which the dollar limit will apply. Existing chart codes may be retrieved from the lookup 🔍.
Organization Code	The organization code associated with the account to which the dollar limit will apply. Existing organization codes may be retrieved from the lookup 🔍.

Purchasing/Accounts
Payable Maintenance E-Docs

Account Number	The account number to which this dollar limit will apply. Existing account numbers may be retrieved from the lookup  .
Negative Payment Request Approval Limit Amount	Required. The dollar limit above which payment requests will be excluded from automated approval.
Active Indicator	Required. Indicates whether this negative payment request approval limit is active or inactive. Remove the check mark to deactivate.

Note Type

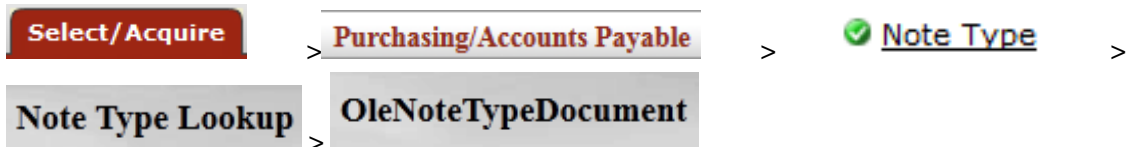

The Note Type document identifies the types of notes, e.g., Receipt Note, Special Conditions Note, or Special Processing Instruction Note that may be associated with Purchasing and Accounts Payable documents.

Document Layout

OleNoteTypeDocument Doc Nbr: 4094
Initiator: ole-khu

Document Overview ▼ hide

Document Overview

* Description: <input type="text"/>	Explanation: <input type="text"/>
Organization Document Number: <input type="text"/>	

Edit Note Type ▼ hide

Old	New
Note Type: Miscellaneous/Other Note	* Note Type: Miscellaneous/Other Note
Active Indicator: Yes	Active Indicator: <input checked="" type="checkbox"/>

Notes and Attachments (0) ▶ show

Ad Hoc Recipients ▶ show

Route Log ▶ show

The Note Type document includes the **Edit Note Type** tab. The system automatically enters data into both the **Old** and **New** sections in this tab. Selected data fields are available for editing.

Edit Note Type tab definition

Title	Description
Note Type	Required. A description or name of the note type.
Active Indicator	Indicates whether this note type parameter is active or inactive. Remove the check mark to deactivate.

Organization Parameter

Select/Acquire > Purchasing/Accounts Payable > • Organization Parameter >
Organization Parameter Lookup >
Organization Parameter Lookup

The Organization Parameter document defines an APO dollar amount limit for a specific organization as identified by a unique combination of chart and organization code.

Document Layout

Organization Parameter ?		Doc Nbr: 3277
		Initiator: khuntley

Document Overview hide

* Description:	<input type="text"/>	Explanation:	<input type="text"/>
Org. Doc. #:	<input type="text"/>		

Edit Organization Parameter hide

Old		New	
Chart Code:	BA	Chart Code:	BA
Organization Code:	ABDR	Organization Code:	ABDR
Organization APO Limit:	5,000.00	Organization APO Limit:	<input type="text" value="5,000.00"/>
Active Indicator:	Yes	Active Indicator:	<input checked="" type="checkbox"/>

Notes and Attachments (0) show

Ad Hoc Recipients show

Route Log show

submit save blanket approve close cancel

The Organization Parameter document includes the **Edit Organization Parameter** tab. The system automatically enters data into both the **Old** and **New** sections in this tab. Selected data fields are available for editing.

Edit Organization Parameter tab definition

Title	Description
Chart Code	The chart code of the organization for which you want to create an APO limit.
Organization Code	The organization code that identifies the organization for which you want to create an APO limit.
Organization APO Limit	The upper dollar amount that you want this organization to be authorized for on APOs.
Active Indicator	Indicates whether this organization parameter is active or inactive. Remove the check mark to deactivate.

Order Type

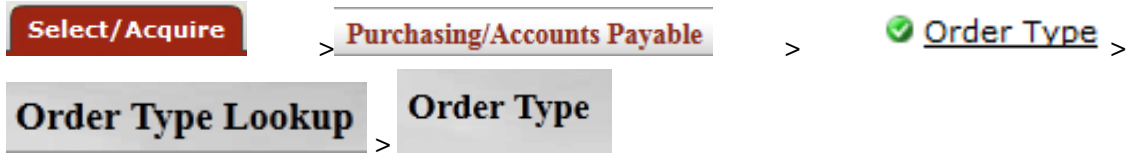

Order Type identifies the type of order which affects workflow e.g., Firm, Standing, Subscription, etc.

Document Layout

Order Type ?

Doc Nbr: 4093	Status: INITIATED
Initiator: ole-khuntley	Created: 02:43 PM

expand all collapse all * require

Document Overview hide

Document Overview

* **Description:**

Organization Document Number:

Explanation:

Edit Order Type hide

Old	New
<p>Order Type: Firm, Fixed</p> <p>Description: Firm orders are commitments from a library to purchase a quantity of a title from a provider. Once all quantities are resolved on a firm order (received & paid for, or cancelled) the order is considered complete and that no further relationship continues with a provider with regards to that firm order.</p> <p>Active Indicator: Yes</p>	<p>* Order Type: Firm, Fixed</p> <p>Description: Firm orders are commitments from a library to purchase a quantity of a title from a provider. Once all quantities are resolved on a firm order (received & paid for, or cancelled) the order is considered complete and that no further relationship continues with a provider with regards to that firm order.</p> <p>Active Indicator: <input checked="" type="checkbox"/></p>

Notes and Attachments (0) show

Ad Hoc Recipients show

Route Log show

The Order Type document includes the **Edit Order Type** tab. The system automatically enters data into both the **Old** and **New** sections in this tab. Selected data fields are available for editing.

Edit Order Type tab definition

Title	Description
Order Type	Required. A name of the order type.
Description	A description of the order type.
Active Indicator	Indicates whether this order type is active or inactive. Remove the check mark to deactivate.

Payment Method

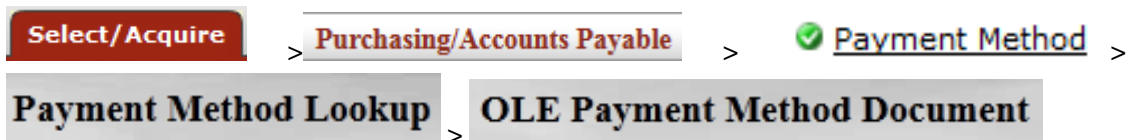

Payment method identifies the method of payment for invoicing e.g., check, cash, wire transfer, etc.

Document Layout

OLE Payment Method Document ?

Doc Nbr: 4092
Initiator: ole-khu

Document Overview
▼ hide

* Description: <input style="width: 90%;" type="text"/>	Explanation: <input style="width: 95%; height: 40px;" type="text"/>
Organization Document Number: <input style="width: 90%;" type="text"/>	

Edit Payment Method
▼ hide

Old	New
Payment Method: Check	* Payment Method: Check
Payment Method Description: Check	Payment Method Description: Check
Active Indicator: Yes	Active Indicator: <input checked="" type="checkbox"/>

Notes and Attachments (0) ▶ show

Ad Hoc Recipients ▶ show

Route Log ▶ show

submit
save
blanket approve
close
cancel

The Payment Method document includes the **Edit Payment Method** tab. The system automatically enters data into both the **Old** and **New** sections in this tab. Selected data fields are available for editing.

Edit Payment Method tab definition

Title	Description
Payment Method	Required. A name of the payment method.
Payment Method Description	A description of the payment method.
Active Indicator	Indicates whether this payment method is active or inactive. Remove the check mark to deactivate.

Payment Request Auto Approve Exclusions

Select/Acquire
Purchasing/Accounts Payable
>

- Payment Request Auto Approve Exclusions
>
- Payment Request Auto Approve Exclusions Lookup
>
- Payment Request Auto Approve Exclusions
>

Payment requests using specified accounts can be excluded from the automatic approval process which approves an eligible en route document automatically after a specified number of days. The Payment

Request Auto Approve Exclusions document identifies the accounts that should be excluded from automated approval.

Document Layout

Payment Request Auto Approve Exclusions ?

Doc Nbr:	3278
Initiator:	khuntle

Document Overview
▼ hide

* Description: <input style="width: 95%;" type="text"/>	Explanation: <input style="width: 95%;" type="text"/>
Org. Doc. #: <input style="width: 80%;" type="text"/>	

Edit Auto Approve Exclude
▼ hide

Old	New
Chart Code: BA	Chart Code: BA
Account Number: 9019995	Account Number: 9019995
Active Indicator: Yes	Active Indicator: <input checked="" type="checkbox"/>

Notes and Attachments (0)
▶ show

Ad Hoc Recipients
▶ show

Route Log
▶ show

submit
save
blanket approve
close
cancel

The Payment Request Auto Approve Exclusions document includes the **Edit Auto Approve Exclude** tab. The system automatically enters data into both the **Old** and **New** sections in this tab. Selected data fields are available for editing.

Edit Auto Approve Exclude tab definition

Title	Description
Chart Code	The Chart of Accounts code associated with the account to be excluded.
Account Number	The account number to be excluded from auto approval.
Active Indicator	Indicates whether this payment request auto approval exclusion is active or inactive. Remove the check mark to deactivate.

Purchase Order Contract Language

Select/Acquire

>

Purchasing/Accounts Payable

>

- Purchase Order Contract Language
>
- Purchase Order Contract Language Lookup
>
- Purchase Order Contract Language
>

The Purchase Order Contract Language document defines text to be included in purchase order contracts. The contract language is defined by campus, allowing variations among campus offices and inclusion of campus-specific language.

Document Layout

Purchase Order Contract Language ?		Doc Nbr: 3280
		Initiator: khuntle

Document Overview ▼ hide

Document Overview	
* Description: <input type="text"/>	Explanation: <input type="text"/>
Org. Doc. #: <input type="text"/>	

Edit PO Contract Language ▼ hide

Old		New	
Purchasing Office Campus Code:	BL - BLOOMINGTON	* Purchasing Office Campus Code:	BL - BLOOMINGTON ▼
Purchase Order Contract Language Description:	All deliveries are to be made to the address and room number as listed above.	* Purchase Order Contract Language Description:	All deliveries are to be made to the address and room number as listed above.
Contract Language Create Date:	05/08/2007	Contract Language Create Date:	05/08/2007
Active Indicator:	Yes	Active Indicator:	<input checked="" type="checkbox"/>

Notes and Attachments (0) ▶ show

Ad Hoc Recipients ▶ show

Route Log ▶ show

The Purchase Order Contract Language document includes the **Edit PO Contract Language** tab. The system automatically enters data into both the **Old** and **New** sections in this tab. Selected data fields are available for editing.

Edit PO Contract Language tab definition

Title	Description
Purchasing Office Campus Code	Required. The campus code that uses this contract language. Existing campus codes may be retrieved from the list.
Purchase Order Contract Language Description	Required. Language description associated with this PO contract related to this campus code.
Contract Language Create Date	Display only. This field is filled automatically, indicating the date on which this contract language was created in the system.
Active Indicator	Indicates whether this purchase order contract language code is active or inactive. Remove the check mark to deactivate this code.

Purchase Order Item Status

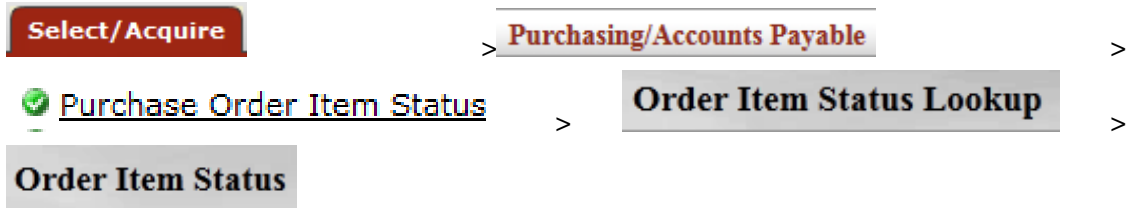

The Purchase Order Item Status identifies the status of individual purchase order items e.g., On order, Received, In process.

Document Layout

Order Item Status ?		Doc Nbr: 3568
		Initiator: ole-khu

Document Overview hide

* Description: <input type="text"/>	Explanation: <input type="text"/>
Organization Document Number: <input type="text"/>	

Edit Order Item Status hide

Old	New
Order Item Status Type: On order	* Order Item Status Type: On order
Description: PO has been sent to vendor; awaiting receipt	Description: PO has been
Active Indicator: Yes	Active Indicator: <input checked="" type="checkbox"/>

Notes and Attachments (0) show

Ad Hoc Recipients show

Route Log show

submit save blanket approve close cancel

The Purchase Order Item Status document includes the **Edit Order Item Status** tab. The system automatically enters data into both the **Old** and **New** sections in this tab. Selected data fields are available for editing.

Edit PO Contract Language tab definition

Title	Description
Order item Status Type	Required. A name of the order item status type.
Description	A description of the order item status type.
Active Indicator	Indicates whether this order item status type is active or inactive. Remove the check mark to deactivate this type.

Purchase Order Quote Language

Select/Acquire > **Purchasing/Accounts Payable** >

- Purchase Order Quote Language >

Purchase Order Quote Language Lookup >

Purchase Order Quote Language

The Purchase Order Quote Language document defines the terms and conditions that print on every request for quotation.

Document Layout

Purchase Order Quote Language ? Doc Nbr: 3281
Initiator: khuntle

Document Overview hide

Document Overview

* Description: <input type="text"/>	Explanation: <input type="text"/>
Org. Doc. #: <input type="text"/>	

Edit Purchase Order Quote Language hide

Old	New
Purchase Order Quote Language Description: - No substitutes will be considered unless a complete description is given. Active: YES	* Purchase Order Quote Language Description: - No substitutes will be considered unless a complete o Active: <input checked="" type="checkbox"/>
Purchase Order Quote Language Create Date: 05/16/2007	Purchase Order Quote Language Create Date: 05/16/2007

Notes and Attachments (0) show

Ad Hoc Recipients show

Route Log show

submit save blanket approve close cancel

The Purchase Order Quote Language document includes the **Edit Purchase Order Quote Language** tab. The system automatically enters data into both the **Old** and **New** sections in this tab. Selected data fields are available for editing.

Edit Purchase Order Quote Language tab definition

Title	Description

Purchase Order Quote Language Description	Required. Enter the PO quote language specifying conditions and requirements for responding to a quote.
Active	Indicates whether this purchase order quote language is active or inactive. Remove the check mark to deactivate.
Purchase Order Quote Language Create Date	Display only. The date defaults to the current date for 'new and copy' actions.

Purchase Order Quote List

Select/Acquire > Purchasing/Accounts Payable > Purchase Order Quote List > Purchase Order Quote List Lookup > Purchase Order Quote List

The Purchase Order Quote List document defines lists of vendors that have been created for a specific commodity. For example, a purchasing agent may need to get a quote for electrical supplies. Rather than add each electrical supply vendor to the quote one-by-one, he or she may select a pre-existing list of available electrical suppliers.

Document Layout

The Purchase Order Quote List document includes the **Edit Quote List** tab and the **Vendors** tab. The system automatically enters data into both the **Old** and **New** sections in this tab. Selected data fields are available for editing.

Purchase Order Quote List	Doc Nbr: 3282
	Initiator: khuntle

Document Overview ▼ hide

* Description: <input type="text"/>	Explanation: <input type="text"/>
Org. Doc. #: <input type="text"/>	

Edit Quote List ▼ hide

Old	New
Purchase Order Quote List Name: Computer Supplies	* Purchase Order Quote List Name: Computer Supplies
Contract Manager: CAIN,IVERSON D	* Contract Manager: <input type="text" value="CAIN,IVERSON D"/>
Active Indicator: Yes	* Active Indicator: <input checked="" type="checkbox"/>

Vendors ▼ hide

New Vendor

*** Vendor #:**

Vendor Name:

Old	New
Vendor #: <u>1011-0</u>	Vendor #: <u>1011-0</u>
Vendor Name: <u>FOREIGN VENDOR RESTRICTED</u>	Vendor Name: <u>FOREIGN</u>

Old	New
Vendor #: <u>1020-2</u>	Vendor #: <u>1020-2</u>
Vendor Name: <u>EASTMAN DIGITAL</u>	Vendor Name: <u>EASTMAN</u>

Old	New
Vendor #: <u>2021-0</u>	Vendor #: <u>2021-0</u>
Vendor Name: <u>COFFEE CUP CAFE</u>	Vendor Name: <u>COFFEE</u>

Notes and Attachments (0) ▶ show

Ad Hoc Recipients ▶ show

Route Log ▶ show

Edit Quote List tab definition

Title	Description
Purchase Order Quote List Name	Required. The name of this PO quote list.
Contract Manager	Required. The contract manager for the quote list. Existing contract managers may be retrieved from the list or from the lookup
Active Indicator	Indicates whether this purchase order quote list is active or inactive. Remove the check mark to deactivate.

Vendors Tab

The screenshot shows the 'Vendors' tab interface. At the top, there is a 'hide' button. Below it is the 'New Vendor' section with a form containing a '* Vendor #' field with a search icon and a 'Vendor Name:' field. An 'add' button is located at the bottom right of this section. Below the 'New Vendor' section is a list of existing vendors, each with a 'hide' button and a title like 'Vendor(1011-0)'. Each vendor entry is split into 'Old' and 'New' columns. The 'Old' column contains the 'Vendor #' and 'Vendor Name' for the current vendor, while the 'New' column contains the 'Vendor #' and 'Vendor Name' for a new vendor being added.

Vendor(1011-0)	
Old	New
Vendor #: 1011-0	Vendor #: 1011-0
Vendor Name: FOREIGN VENDOR RESTRICTED	Vendor Name: FOREIGN VENDOR RESTRICTED

Vendor(1020-2)	
Old	New
Vendor #: 1020-2	Vendor #: 1020-2
Vendor Name: EASTMAN DIGITAL	Vendor Name: EASTMAN DIGITAL

Vendor(2021-0)	
Old	New
Vendor #: 2021-0	Vendor #: 2021-0
Vendor Name: COFFEE CUP CAFE	Vendor Name: COFFEE CUP CAFE

Note that more than one vendor may be assigned to the quote list using the 'add' functionality.

Vendors tab definition

Title	Description
Vendor #	Required. The vendor number. Existing vendor numbers may be retrieved from the lookup  .
Vendor Name	Display-only. The field is populated when a valid vendor number is selected.

Purchase Order Quote Status

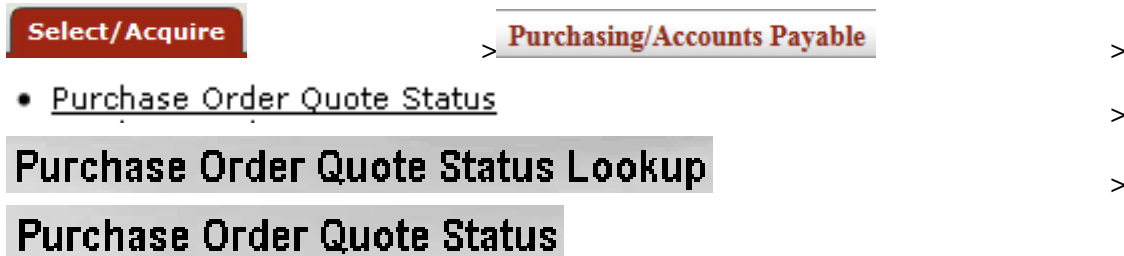

The Purchase Order Quote Status document defines the status options that may be assigned by a purchasing agent to each vendor in an existing quotation. For example, a vendor who did not submit a bid would be given the status 'No Response'. For a vendor who submitted a bid that was unacceptable, the vendor would be given the status, 'Received, Bid Unacceptable'.

Document Layout

Purchase Order Quote Status		Doc Nbr: 3285
		Initiator: khuntle

Document Overview ▼ hide

* Description: <input type="text"/>	Explanation: <input type="text"/>
Org. Doc. #: <input type="text"/>	

Edit Purchase Order Quote ▼ hide

Old	New
Purchase Order Quote Status Code: RCAC	Purchase Order Quote Status Code: RCAC
Purchase Order Quote Status Description: Received, Bid Acceptable	* Purchase Order Quote Status Description: Received, Bid
Active Indicator: Yes	Active Indicator: <input checked="" type="checkbox"/>

Notes and Attachments (0) ▶ show

Ad Hoc Recipients ▶ show

Route Log ▶ show

submit save blanket approve close cancel

The Purchase Order Quote Status document includes the **Edit Purchase Order Quote** tab. The system automatically enters data into both the **Old** and **New** sections in this tab. Selected data fields are available for editing.

Edit Purchase Order Quote tab definition

Title	Description
Purchase Order Quote Status Code	A unique code to identify a particular PO quote status.
Purchase Order Quote Status Description	Required. A description of the PO quote status.
Active Indicator	Indicates whether this purchase order quote status is active or inactive. Remove the check mark to deactivate.

Purchase Order Vendor Choice

Select/Acquire > **Purchasing/Accounts Payable** >

- Purchase Order Vendor Choice >

Purchase Order Vendor Choice Lookup >

Purchase Order Vendor Choice

The Purchase Order Vendor Choice document defines reasons that indicate why a specific vendor was chosen for a purchase.

Document Layout

Purchase Order Vendor Choice ?

Doc Nbr: 3288
Initiator: khuntle

Document Overview ▼ hide

Document Overview	
* Description: <input style="width: 95%;" type="text"/>	Explanation: <input style="width: 95%;" type="text"/>
Org. Doc. #: <input style="width: 80%;" type="text"/>	

Edit PO Vendor Choice ▼ hide

Old	New
Purchase Order Vendor Choice Code: CNST	Purchase Order Vendor Choice Code: CNST
Purchase Order Vendor Choice Description: Construction	* Purchase Order Vendor Choice Description: Construction
Active Indicator: Yes	Active Indicator: <input checked="" type="checkbox"/>

Notes and Attachments (0) ▶ show

Ad Hoc Recipients ▶ show

Route Log ▶ show

submit
save
blanket approve
close
cancel

The Purchase Order Vendor Choice document includes the **Edit PO Vendor Choice** tab. The system automatically enters data into both the **Old** and **New** sections in this tab. Selected data fields are available for editing.

Edit PO Vendor Choice tab definition

Title	Description
Purchasing Order Vendor Choice Code	The code to identify the reason for selecting this vendor.
Purchase Order Vendor Choice Description	Required. The familiar title for the purchase order vendor choice code.
Active Indicator	Indicates whether this purchase order vendor choice code is active or inactive. Remove the check mark to deactivate this code.

Receiving Address

Select/Acquire

>

Purchasing/Accounts Payable

>

•

Receiving Address

>

Receiving Address Lookup

>

Receiving Address

The Receiving Address document defines the possible default receiving addresses for each department.

Document Layout

Receiving Address		Doc Nbr: 3289
		Initiator: khuntle

Document Overview
▼ hide

* Description: <input style="width: 90%;" type="text"/>	Explanation: <input style="width: 90%;" type="text"/>
Org. Doc. #: <input style="width: 80%;" type="text"/>	

Edit Receiving Address
▼ hide

Old	New
Chart Code: BL	* Chart Code: <input style="width: 80%;" type="text"/>
Organization Code:	Organization Code: <input style="width: 80%;" type="text"/>
Receiving Name: KUALI UNIVERSITY	* Receiving Name: KUALI UNIVERSITY
Receiving Line 1 Address: 400 E. Main Street	* Receiving Line 1 Address: 400 E. Main Street
Receiving Line 2 Address: Central Receiving	Receiving Line 2 Address: Central Receiving
Receiving City Name: KualI City	* Receiving City Name: KualI City
Receiving State Code: WYOMING	Receiving State Code: WYOMING
Receiving Postal Code: 83444	Receiving Postal Code: <input style="width: 80%;" type="text"/>
Receiving Country Code: UNITED STATES	* Receiving Country Code: UNITED STATES
Use Receiving Address Indicator: Yes	Use Receiving Address Indicator: <input checked="" type="checkbox"/>
Default Indicator: Yes	Default Indicator: <input checked="" type="checkbox"/>
Active Indicator: Yes	Active Indicator: <input checked="" type="checkbox"/>

Notes and Attachments (0)	▶ show
Ad Hoc Recipients	▶ show
Route Log	▶ show

submit
save
blanket approve
close
cancel

The Receiving Address document includes the **Edit Receiving Address** tab. The system automatically enters data into both the **Old** and **New** sections in this tab. Selected data fields are available for editing.

Edit Receiving Address tab definition

Title	Description
Chart Code	Required. The Chart of Accounts code associated with this organization. Existing chart codes may be retrieved from the lookup
Organization Code	Optional. The organization code associated with the receiving address. Existing organization codes may be retrieved from the lookup
Receiving Name	Required. The familiar title of the receiving address.
Receiving Line 1 Address	Required. The first line of the address information for this receiving address.
Receiving Line 2 Address	Optional. The second line of the address information for this receiving address.

Purchasing/Accounts
Payable Maintenance E-Docs

Receiving City Name	Required. The city name associated with this receiving address.
Receiving State Code	The state code associated with this receiving address. Existing state codes may be retrieved from the list.
Receiving Postal Code	The postal code associated with this receiving address.
Receiving Country Code	Required. The country associated with this receiving address. Existing countries may be retrieved from the list.
Use Receiving Address Indicator	Indicates if users are to be allowed to specify the receiving address on requisitions and POs. Clear the box if users are not to be allowed to specify the receiving address (if, for example, all goods are shipped to a central receiving area).
Default Indicator	Indicates if this address is to be used as the default receiving address. Clear the check box if it is not.
Active Indicator	Indicates whether this receiving address is active or inactive. Remove the check mark to deactivate.

Receiving Threshold

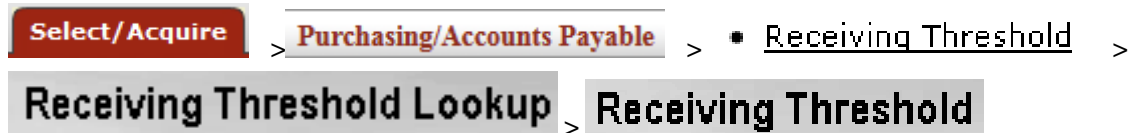

The Receiving Threshold document is used to define criteria that determine when an order requires line-item receiving. When an order meets certain criteria and is above a pre-defined dollar limit, the purchase order will not be paid until line item receiving has occurred.

Document Layout

Receiving Threshold

Doc Nbr: 3290
Initiator: khuntl

Document Overview

Document Overview

* Description: <input type="text"/>	Explanation: <input type="text"/>
Org. Doc. #: <input type="text"/>	

Edit Threshold

Old	New
Chart Code: EA	* Chart Code: EA
Account Type Code:	Account Type Code: <input type="text"/>
Sub-Fund Group Code:	Sub-Fund Group Code: <input type="text"/>
Commodity Code:	Commodity Code: <input type="text"/>
Object Code:	Object Code: <input type="text"/>
Organization Code:	Organization Code: <input type="text"/>
Vendor #:	Vendor #: <input type="text"/>
Threshold Amount: 3000.00	* Threshold Amount: <input type="text" value="3000.00"/>
Active Indicator: Yes	Active Indicator: <input checked="" type="checkbox"/>

Notes and Attachments (0)

Ad Hoc Recipients



Route Log

submit
save
blanket approve
close
cancel

The Receiving Threshold document includes the **Edit Threshold** tab. The system automatically enters data into both the **Old** and **New** sections in this tab. Selected data fields are available for editing.

Edit Threshold tab definition

Title	Description
Chart Code	The Chart of Accounts code associated with this receiving threshold. Existing chart codes may be retrieved from the lookup
Account Type Code	The account type code to be used on this receiving threshold. Existing account type codes may be retrieved from the list or from the lookup
Sub-Fund Group Code	The sub fund group code associated with this receiving threshold. Existing sub fund group codes may be retrieved from the lookup
Commodity Code	The commodity code associated with this receiving threshold. Existing commodity codes may be retrieved from the lookup

Object Code	The object code associated with this receiving threshold. Existing object codes may be retrieved from the lookup 
Organization Code	The organization code associated with this receiving threshold. Existing organization codes may be retrieved from the lookup 
Vendor #	The vendor number associated with this receiving threshold. Existing vendor numbers may be retrieved from the lookup 
Threshold Amount	Required. The minimum amount that is required to be processed through the receiving process.
Active Indicator	Indicates whether this receiving threshold is active or inactive. Remove the check mark to deactivate.

Recurring Payment Frequency

Select/Acquire > **Purchasing/Accounts Payable** >

- Recurring Payment Frequency >

Recurring Payment Frequency Lookup >

Recurring Payment Frequency

The Recurring Payment Frequency document defines payment frequency periods, such as 'annually,' 'monthly,' or 'quarterly.'

Document Layout

Recurring Payment Frequency 	Doc Nbr: 3295
	Initiator: khuntle

Document Overview ▼ hide

Document Overview

* Description: <input type="text"/>	Explanation: <input type="text"/>
Org. Doc. #: <input type="text"/>	

Edit Recurring Pmt Frequency ▼ hide

Old	New
Recurring Payment Frequency Code: MONT	Recurring Payment Frequency Code: MONT
Recurring Payment Frequency Description: MONTHLY	* Recurring Payment Frequency Description: MONTHLY
Active Indicator: Yes	Active Indicator: <input checked="" type="checkbox"/>

Notes and Attachments (0) ▶ show

Ad Hoc Recipients ▶ show

Route Log ▶ show

submit save blanket approve close cancel

The Recurring Payment Frequency document includes the Edit **Recurring Pmt Frequency** tab. The system automatically enters data into both the **Old** and **New** sections in this tab. Selected data fields are available for editing.

Edit Recurring Pmt Frequency tab definition

Title	Description
Recurring Payment Frequency Code	The code to identify this type of recurring payment frequency.
Recurring Payment Frequency Description	Required. The familiar title of this recurring payment frequency.
Active Indicator	Indicates whether this recurring payment frequency code is active or inactive. Remove the check mark to deactivate this code.

Recurring Payment Type

Select/Acquire > Purchasing/Accounts Payable > • Recurring Payment Type >
Recurring Payment Type Lookup >
Recurring Payment Type

This Recurring Payment Type document defines different types of recurring payments that can be established for a purchase order. Examples might include 'Fixed Schedule, Fixed Payment' or 'Fixed Schedule, Variable Amount.

Document Layout

Recurring Payment Type Doc Nbr: 3296
Initiator: khuntle

Document Overview ▼ hide

* Description:	Explanation:
Org. Doc. #:	

Edit Recurring Payment Type ▼ hide

Old	New
Recurring Payment Type Code: FIXD	Recurring Payment Type Code: FIXD
Recurring Payment Type Description: FIXED SCHEDULE, FIXED AMOUNT	* Recurring Payment Type Description: FIXED SCHEDULE
Active Indicator: Yes	Active Indicator: <input checked="" type="checkbox"/>

Notes and Attachments (0) ▶ show

Ad Hoc Recipients ▶ show

Route Log ▶ show

submit save blanket approve close cancel

The Recurring Payment Type document includes the **Edit Recurring Payment Type** tab. The system automatically enters data into both the **Old** and **New** sections in this tab. Selected data fields are available for editing.

Edit Recurring Payment Type tab definition

Title	Description
Recurring Payment Type Code	The code to identify this recurring payment type.
Recurring Payment Type Description	Required. The description of this recurring payment type.
Active Indicator	Indicates whether this recurring payment type code is active or inactive. Remove the check mark to deactivate this code.

Request Source Type

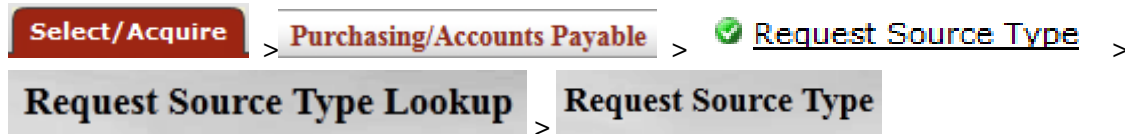

The Request Source Type document identifies the source of the request e.g., WorldCat, Amazon etc.

Document Layout

Request Source Type ?

Doc Nbr: 40

Initiator: pl

Document Overview ▼ hide

*** Description:**

Organization Document Number:

Explanation:

Edit Request Source Type ▼ hide

Old	New
Request Source Type: BatchIngest	* Request Source Type: BatchIngest
Active Indicator: Yes	Active Indicator: <input checked="" type="checkbox"/>

Notes and Attachments (0) ▶ show

Ad Hoc Recipients ▶ show

Route Log ▶ show

submit save blanket approve close cancel

The Request Source Type document includes the **Edit Request Source Type** tab. The system automatically enters data into both the **Old** and **New** sections in this tab. Selected data fields are available for editing.

Edit Request Source Type tab definition

Title	Description
-------	-------------

Request Source Type	Required. The description or name of this request source type.
Active Indicator	Indicates whether this request source type is active or inactive. Remove the check mark to deactivate.

Requisition Source

[Select/Acquire](#) > [Purchasing/Accounts Payable](#) > • [Requisition Source](#) >
[Requisition Source Lookup](#) > [Requisition Source](#)

This table defines different sources for requisitions that can be imported into the Quali AP/Purchasing documents.

Document Layout

Requisition Source ?

Doc Nbr:	3297
Initiator:	khuntlev

Document Overview ▼ hide

Document Overview

* Description: <input type="text"/>	Explanation: <input type="text"/>
Org. Doc. #: <input type="text"/>	

Edit Requisition Source ▼ hide

Old	New
Requisition Source Code: B2B	Requisition Source Code: B2B
Requisition Source Description: B2B	* Requisition Source Description: <input type="text" value="B2B"/>
Active Indicator: Yes	Active Indicator: <input checked="" type="checkbox"/>

Notes and Attachments (0) ▶ show

Ad Hoc Recipients ▶ show

Route Log ▶ show

submit save blanket approve close cancel

The Requisition Source document includes the **Edit Requisition Source** tab. The system automatically enters data into both the **Old** and **New** sections in this tab. Selected data fields are available for editing.

Edit Requisition Source tab definition

Title	Description
Requisition Source Code	The code that identifies this source of requisition information.
Requisition Source Description	Required. The description of this source of requisition.
Active Indicator	Indicates whether this requisition source code is active or inactive. Remove the check mark to deactivate this code.

Sensitive Data

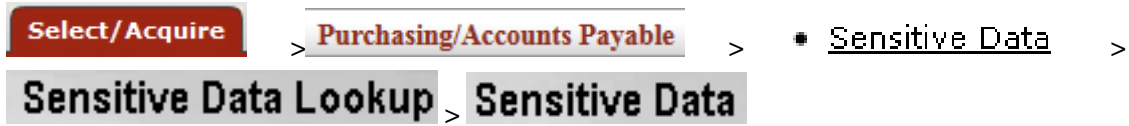

The Sensitive Data document indicates why a Purchase Order document might be restricted from viewing. When a user wants to restrict a document from view because it contains sensitive data, he/she must select a reason why the data is sensitive. After a reason is specified, only authorized staff members may view the document.

Document Layout

Sensitive Data ?		Doc Nbr: 3301
		Initiator: khuntle

Document Overview hide

Document Overview	
* Description: <input type="text"/>	Explanation: <input type="text"/>
Org. Doc. #: <input type="text"/>	

Edit Sensitive Data hide

Old		New	
Sensitive Data Code:	RADI	Sensitive Data Code:	RADI
Sensitive Data Description:	Radio Active Material	* Sensitive Data Description:	Radio Active M
Active Indicator:	Yes	Active Indicator:	<input checked="" type="checkbox"/>

Notes and Attachments (0) show

Ad Hoc Recipients show

Route Log show

submit save blanket approve close cancel

The Sensitive Data document includes the **Edit Sensitive Data** tab. The system automatically enters data into both the **Old** and **New** sections in this tab. Selected data fields are available for editing.

Edit Sensitive Data tab definition

Title	Description
Sensitive Data Code	A unique code to identify a particular type of sensitive data.
Sensitive Data Description	Required. A description of this type of sensitive data.
Active Indicator	Indicates whether this sensitive data code is active or inactive. Remove the check mark to deactivate this code.

Vendor Stipulation

Select/Acquire > Purchasing/Accounts Payable > Vendor Stipulation >
Vendor Stipulation Lookup > Vendor Stipulation

This Vendor Stipulation document defines text to be included in purchase order documents that stipulates order conditions to vendors. The stipulations are defined by a unique identifier, which allows pre-defined stipulation language to be easily added to orders.

Document Layout

Vendor Stipulation ?		Doc Nbr: 3302
		Initiator: khuntle

Document Overview ▼ hide

Document Overview	
* Description:	<input type="text"/>
Org. Doc. #:	<input type="text"/>
Explanation:	
<input type="text"/>	

Edit Vendor Stipulation ▼ hide

Old		New	
Vendor Stipulation Name:	Material Acknowledgment	* Vendor Stipulation Name:	<input type="text" value="Material Acknowledgment"/>
Vendor Stipulation Description:	By acceptance of this Purchase Order the Supplier warrants that material will be free from defects and fit for use as intended. Supplier accepts all terms included for the items herein and the stated delivery expectations. Please acknowledge by fax XXX-XXX-XXXX or email to XXXXXXX@XXXXX.XXX. Your compliance with this directive is imperative.	* Vendor Stipulation Description:	By acceptance of this Purchase Order the Supplier warrants that material will be free from defects and fit for use as intended. Supplier accepts all terms included for the items herein and the stated delivery expectations. Please acknowledge by fax XXX-XXX-XXXX or email to XXXXXXX@XXXXX.XXX. Your compliance with this directive is imperative.
Active Indicator:	Yes	Active Indicator:	<input checked="" type="checkbox"/>

Notes and Attachments (0) ▶ show

Ad Hoc Recipients ▶ show

Route Log ▶ show

submit save blanket approve close cancel

The Vendor Stipulation document includes the **Edit Vendor Stipulation** tab. The system automatically enters data into both the **Old** and **New** sections in this tab. Selected data fields are available for editing.

Edit Vendor Stipulation tab definition

Title	Description
-------	-------------

Vendor Stipulation Name	Required. The familiar title of this vendor stipulation.
Vendor Stipulation Description	Required. The text describing the stipulation conditions and reasons for this vendor stipulation.
Active Indicator	Indicates whether this vendor stipulation is active or inactive. Remove the check mark to deactivate

Licensing Requirement

[Select/Acquire](#) > [Purchasing/Accounts Payable](#) > [Licensing Requirement](#) >
[Licensing Requirement Lookup](#) >
[Licensing Requirement](#)

Licenses are initiated on the requisition when the “Licensing Requirement/Review” is checked. As licenses continue through their workflow, the “Licensing Requirement/Review Status” field on a requisition is automatically updated. The License Requirement document is used to inform the requisition of the workflow and status of the License Request.

Document Layout

Licensing Requirement ?		Doc Nbr:	4116
		Initiator:	ole-khun!

Document Overview ▼ hide

Document Overview

* Description:		Explanation:	
Organization Document Number:			

Edit Order Type ▼ hide

Old		New	
Licensing Requirement Code:	ILR	Licensing Requirement Code:	ILR
Licensing Requirement Description:	Initiate License Request	Licensing Requirement Description:	Initiate License Request
Active Indicator:	Yes	Active Indicator:	<input checked="" type="checkbox"/>

Notes and Attachments (0) ▶ show

Ad Hoc Recipients ▶ show

Route Log ▶ show

The Licensing Requirement document includes the **Edit License Requirement** tab. The system automatically enters data into both the **Old** and **New** sections in this tab. Selected data fields are available for editing.

Edit Requisition Source tab definition

Title	Description
-------	-------------

Licensing Requirement Code	The code that identifies this source of licensing requirement.
Licensing Requirement Description	Required. The description of this licensing requirement.
Active Indicator	Indicates whether this licensing requirement code is active or inactive. Remove the check mark to deactivate this code.

Authentication Type

Select/Acquire > Purchasing/Accounts Payable > ✔ Authentication Type >

Authentication Type

Authentication Types are used to describe the authentication necessary for the E-Resource. Some examples may include IP address or Username and Password.

Document Layout

Authentication Type		Document Number: 5528
		Initiator Network Id: ole-k

Document Overview		
* Description:	<input type="text"/>	Explanation:
Organization Document Number:	<input type="text"/>	<input type="text"/>

Add/Edit Authentication Type		
	Old	New
Authentication Type Name:	IP range	<input type="text" value="IP range"/>
Authentication Type Description:	IP range	<input type="text" value="IP range"/>
Active Indicator:	true	<input checked="" type="checkbox"/>

Notes and Attachments (0)
Ad Hoc Recipients
Route Log

The Authentication Type document includes the Add/Edit Authentication Type tab. The system automatically enters data into both the **Old** and **New** sections. Selected data fields are available for editing.

Add/Edit Authentication Type Tab Definitions

Title	Description
Authentication Type Name	Required. Brief name that will display in the Authentication Type field of the Access tab on the E-Resource Record.

Authentication Type Description	Optional. Include a brief description.
Active Indicator	Indicates whether this status is active or inactive. Remove the check mark to deactivate.

Access Location

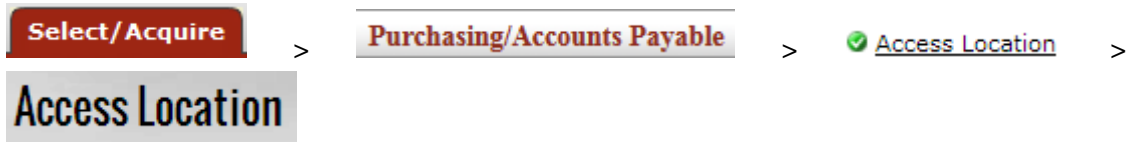

Access Location is used to describe parts or locations of an institution that access has been granted to for a particular E-Resource. Access Locations will be locally configured to be specific to each institution.

Document Layout

Access Location		Document Number: 5536
		Initiator Network Id: ole-k
Document Overview		
* Description:	<input type="text"/>	Explanation:
Organization Document Number:	<input type="text"/>	
Add/Edit Access Location		
	Old	New
Access Location Name:	Main Campus	Main Campus
Access Location Description:	Main Campus	Main Campus
Active Indicator:	true	<input checked="" type="checkbox"/>
Notes and Attachments (0)		
Ad Hoc Recipients		
Route Log		

The Access Location document includes the Add/Edit Access Location tab. The system automatically enters data into both the **Old** and **New** sections. Selected data fields are available for editing.

Add/Edit Access Location Tab Definitions

Title	Description
Access Location Name	Required. Brief name that will display in the Access Location field of the E-Resource Record.

Access Location Description	Optional. Include a brief description.
Active Indicator	Indicates whether this status is active or inactive. Remove the check mark to deactivate.

E-Resource Status

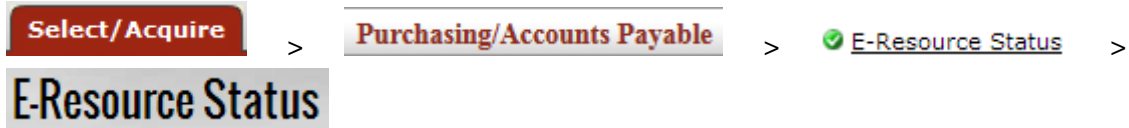

Document Layout

E-Resource Status		Document Number: 5542
		Initiator Network Id: ole-kh
Document Overview		
* Description:	<input type="text"/>	Explanation:
Organization Document Number:	<input type="text"/>	
Add/Edit E-Resource Status		
	Old	New
E-Resource Status Name:	In-Process	<input type="text" value="In-Process"/>
E-Resource Status Description:	Status of E-Res Record	<input type="text" value="Status of E-Res"/>
Active Indicator:	true	<input checked="" type="checkbox"/>
Notes and Attachments (0)		
Ad Hoc Recipients		
Route Log		

The E-Resource Status document includes the Add/Edit E-Resource Status tab. The system automatically enters data into both the **Old** and **New** sections. Selected data fields are available for editing.

Add/Edit E-Resource Status Tab Definitions

Title	Description
E-Resource Status Name	Required. Brief name that will display in the E-Resource Status field of the E-Resource Record.
E-Resource Status Description	Optional. Include a brief description.
Active Indicator	Indicates whether this status is active or inactive. Remove the check mark to deactivate.

Package Type

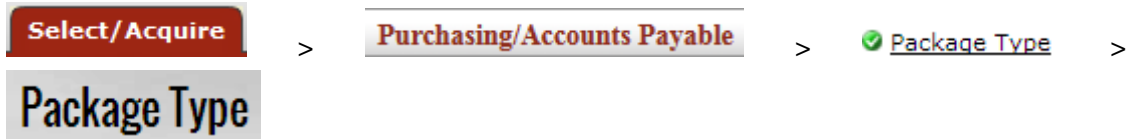

Document Layout

Package Type		Document Number: 5549
		Initiator Network Id: ole-kh
Document Overview		
* Description:	<input type="text"/>	Explanation:
Organization Document Number:	<input type="text"/>	
Add/Edit Package Type		
	Old	New
Package Type Name:	Consortial	<input type="text" value="Consortial"/>
Package Type Description:	Consortial	<input type="text" value="Consortial"/>
Active Indicator:	true	<input checked="" type="checkbox"/>
Notes and Attachments (0)		
Ad Hoc Recipients		
Route Log		

The Package Type document includes the Add/Edit Package Type tab. The system automatically enters data into both the **Old** and **New** sections. Selected data fields are available for editing.

Add/Edit Package Type Tab Definitions

Title	Description
Package Type Name	Required. Brief name that will display in the Package Type field of the E-Resource Record.
Package Type Description	Optional. Include a brief description.
Active Indicator	Indicates whether this status is active or inactive. Remove the check mark to deactivate.

Package Scope

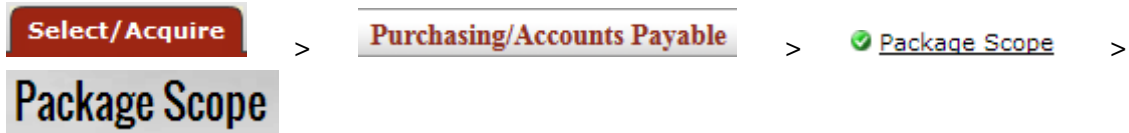

Access Location is used to describe parts or locations of an institution that access has been granted to for a particular E-Resource. Access Locations will be locally configured to be specific to each institution.

Document Layout

Package Scope		Document Number: 5554
		Initiator Network Id: ole-k
▼ Document Overview		
* Description:	<input type="text"/>	Explanation: <input type="text"/>
Organization Document Number:	<input type="text"/>	
▼ Add/Edit Package Scope		
	Old	New
Package Scope Name:	Front File	<input type="text" value="Front File"/>
Package Scope Description:	Front File	<input type="text" value="Front File"/>
Active Indicator:	true	<input checked="" type="checkbox"/>
▶ Notes and Attachments (0)		
▶ Ad Hoc Recipients		
▶ Route Log		

The Package Scope document includes the Add/Edit Package Scope tab. The system automatically enters data into both the **Old** and **New** sections. Selected data fields are available for editing.

Add/Edit Package Scope Tab Definitions

Title	Description
Package Scope Name	Required. Brief name that will display in the Package Scope field of the E-Resource Record.
Package Scope Description	Optional. Include a brief description.
Active Indicator	Indicates whether this status is active or inactive. Remove the check mark to deactivate.

Material Type

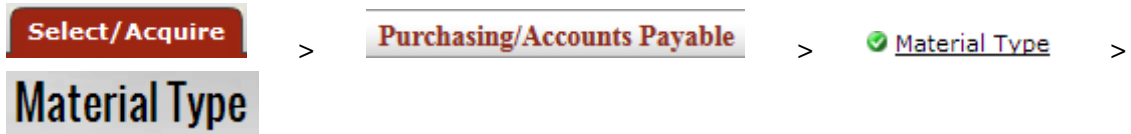

Document Layout

Material Type	Document Number:	5558
	Initiator Network Id:	ole-kl

▼ Document Overview

* Description:	test	Explanation:	
Organization Document Number:			

▼ Add/Edit Material Type

	Old	New
Material Type Name:	Journal	Journal
Material Type Description:	Journal of the material	Journal of the material
Active Indicator:	true	<input checked="" type="checkbox"/>

- ▶ Notes and Attachments (0)
- ▶ Ad Hoc Recipients
- ▶ Route Log

The Material Type document includes the Add/Edit Material Type tab. The system automatically enters data into both the **Old** and **New** sections. Selected data fields are available for editing.

Add/Edit Material Type Tab Definitions

Title	Description
Material Type Name	Required. Brief name that will display in the Material Type field of the E-Resource Record.
Material Type Description	Optional. Include a brief description.
Active Indicator	Indicates whether this status is active or inactive. Remove the check mark to deactivate.

Access Type



Document Layout

Access Type		Document Number: 5561
		Initiator Network Id: ole-kh
▼ Document Overview		
* Description:	<input type="text"/>	Explanation: <input type="text"/>
Organization Document Number:	<input type="text"/>	
▼ Add/Edit Access Type		
	Old	New
Access Type Name:	site-wide	<input type="text" value="site-wide"/>
Access Type Description:	site-wide	<input type="text" value="site-wide"/>
Active Indicator:	true	<input checked="" type="checkbox"/>
▶ Notes and Attachments (0)		
▶ Ad Hoc Recipients		
▶ Route Log		

The Access Type document includes the Add/Edit Access Type tab. The system automatically enters data into both the **Old** and **New** sections. Selected data fields are available for editing.

Add/Edit Access Type Tab Definitions

Title	Description
Access Type Name	Required. Brief name that will display in the Access Type field of the E-Resource Record.
Access Type Description	Optional. Include a brief description.
Active Indicator	Indicates whether this status is active or inactive. Remove the check mark to deactivate.

Content Type

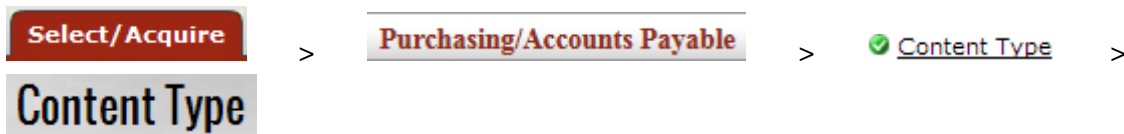

Document Layout

Content Type	Document Number: 5565
	Initiator Network Id: ole-kh

▼ **Document Overview**

* Description:	<input type="text"/>	Explanation:	<input type="text"/>
Organization Document Number:	<input type="text"/>		

▼ **Add/Edit Content Type**

	Old	New
Content Type Name:	Text	<input type="text" value="Text"/>
Content Type Description:	Text	<input type="text" value="Text"/>
Active Indicator:	true	<input checked="" type="checkbox"/>

- ▶ **Notes and Attachments (0)**
- ▶ **Ad Hoc Recipients**
- ▶ **Route Log**

The Content Type document includes the Add/Edit Content Type tab. The system automatically enters data into both the **Old** and **New** sections. Selected data fields are available for editing.

Add/Edit Content Type Tab Definitions

Title	Description
Content Type Name	Required. Brief name that will display in the Content Type field of the E-Resource Record.
Content Type Description	Optional. Include a brief description.
Active Indicator	Indicates whether this status is active or inactive. Remove the check mark to deactivate.

Payment Type

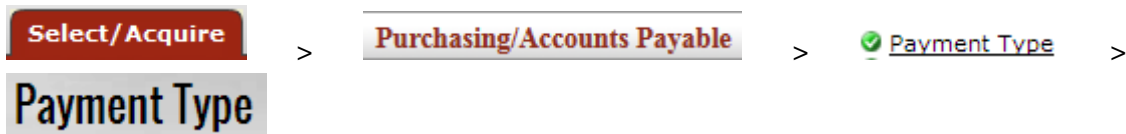

Document Layout

Payment Type	Document Number: 5573
	Initiator Network Id: ole-kl

Document Overview	
* Description:	<input type="text"/>
Organization Document Number:	<input type="text"/>
Explanation:	<input type="text"/>

Add/Edit Payment Type		
	Old	New
Payment Type Name:	Free	Free
Payment Type Description:	Free Payment Type	Free Payment T
Active Indicator:	true	<input checked="" type="checkbox"/>

- ▶ **Notes and Attachments (0)**
- ▶ **Ad Hoc Recipients**
- ▶ **Route Log**

The Payment Type document includes the Add/Edit Payment Type tab. The system automatically enters data into both the **Old** and **New** sections. Selected data fields are available for editing.

Add/Edit Payment Type Tab Definitions

Title	Description
Payment Type Name	Required. Brief name that will display in the Payment Type field of the E-Resource Record.
Payment Type Description	Optional. Include a brief description.
Active Indicator	Indicates whether this status is active or inactive. Remove the check mark to deactivate.

Request Priority

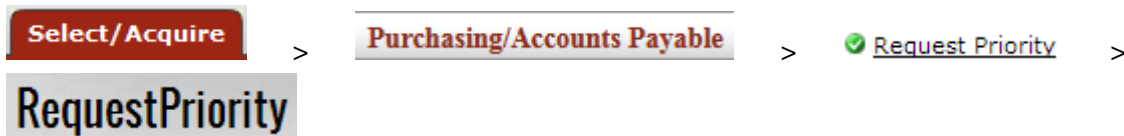

Document Layout

RequestPriority	Document Number: 5578
	Initiator Network Id: ole-kh

Document Overview	
* Description: <input type="text"/>	Explanation: <input type="text"/>
Organization Document Number: <input type="text"/>	

Add/Edit RequestPriority		
	Old	New
RequestPriority Name:	1	<input type="text" value="1"/>
RequestPriority Description:	Least Priority	<input type="text" value="Least Priority"/>
Active Indicator:	true	<input checked="" type="checkbox"/>

- ▶ **Notes and Attachments (0)**
- ▶ **Ad Hoc Recipients**
- ▶ **Route Log**

The Request Priority document includes the Add/Edit Request Priority tab. The system automatically enters data into both the **Old** and **New** sections. Selected data fields are available for editing.

Add/Edit Request Priority Tab Definitions

Title	Description
Request Priority Name	Required. Brief name that will display in the Request Priority field of the E-Resource Record.
Request Priority Description	Optional. Include a brief description.
Active Indicator	Indicates whether this status is active or inactive. Remove the check mark to deactivate.

General Ledger Introduction

The General Ledger (GL) contains numerous processes that ensure that OLE runs correctly. For users processing e-doc transactions, the most apparent of these processes are the generation of offsets and the posting of transactions to the balance tables. Other important General Ledger processes are less apparent to users. These processes ensure that transaction data are valid, that capitalization entries are created, and that indirect cost recovery and cost share transfers occur. OLE also offers related features such as sufficient funds checking and flexible offsets for institutions that want to utilize this functionality.

OLE will apply encumbrances and expenses to the General Ledger as a result of OLE implemented functionality for encumbrances, expenses, budget adjustments and transfers of funds. Real-time GL posting is made available, with certain GL entries updating their status through nightly “batch jobs”.

Note

We continue to reconcile university financial integrations and OLE's use of Budget vs. Actual (cash) balances in our coding efforts.

Requisition

- No GL entries for this form of “pre-order”

Purchase Order, Purchase Order Amendment, other forms of PO

- A final, “approved” Purchase Order will apply an encumbrance to the General Ledger as “pending”. During nightly batch jobs, the pending entry goes to “final”. Pending GL entries will be visible on the PO's General Ledger Pending Entries tab, and be reflected in balance inquiries when “pending” or “all” transactions included.
- Sample: pending GL entry from approved PO with default (OLE Sample Data/object code 9892- RESV OUTSTANDING ORDR EXTRNL ENCUMBRNCES, Credit offset to the purchase order Debit) Offset- not yet processed through nightly batch job

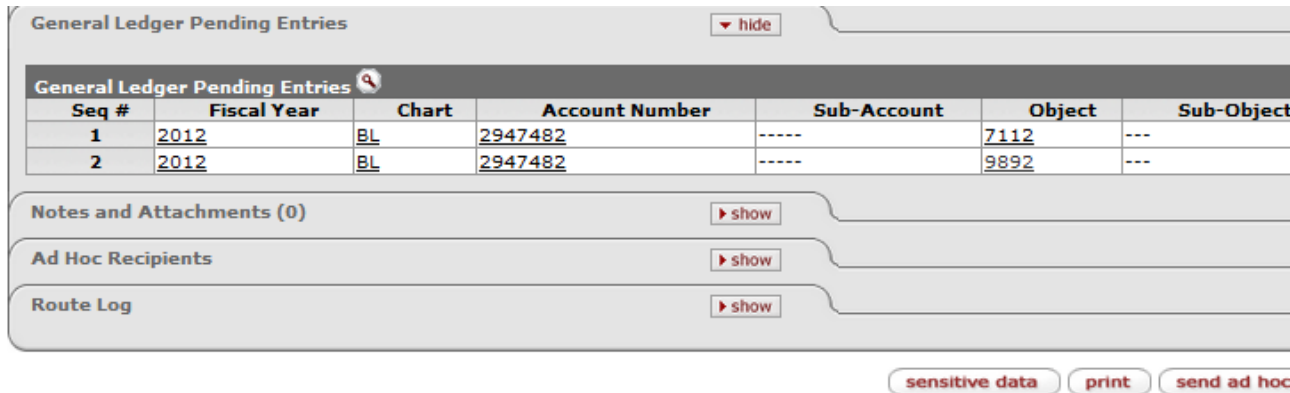

General Ledger Pending Entries

Seq #	Fiscal Year	Chart	Account Number	Sub-Account	Object	Sub-Object
1	2012	BL	2947482	----	7112	---
2	2012	BL	2947482	----	9892	---

Notes and Attachments (0) [show](#)

Ad Hoc Recipients [show](#)

Route Log [show](#)

[sensitive data](#) [print](#) [send ad hoc](#)

- Sample: PO that has processed to nightly batch job- no pending GL entries

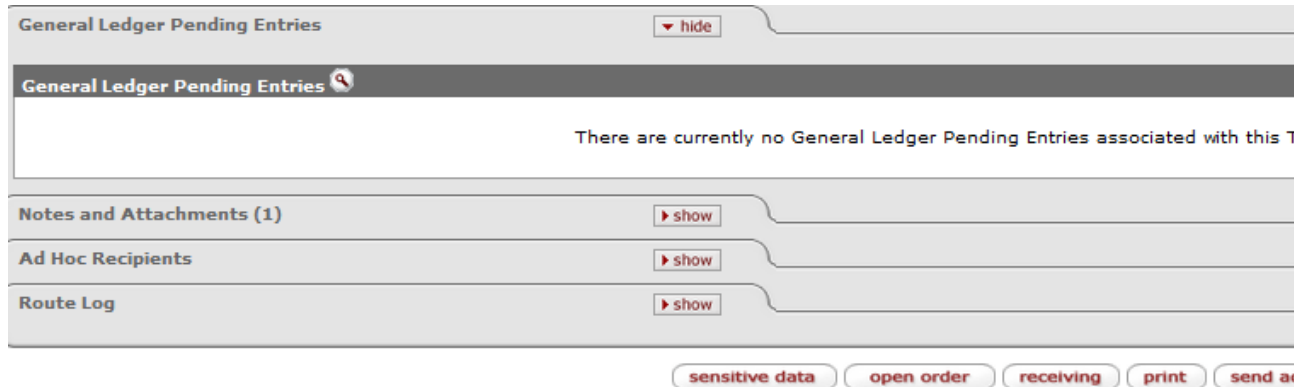

General Ledger Pending Entries

There are currently no General Ledger Pending Entries associated with this T

Notes and Attachments (1) [show](#)

Ad Hoc Recipients [show](#)

Route Log [show](#)

[sensitive data](#) [open order](#) [receiving](#) [print](#) [send ad hoc](#)

Payment Request

- As PREQ's are payments to vendors, any PREQ created with accounting lines will post to the GL as “pending” whether it has completed workflow or not (unlike PO which must be final/approved).

- PREQ will reverse the encumbrance, as noted on the e-Doc, and apply the expense immediately.
- Nightly batch jobs will take approved PREQ's to final status, and also apply liabilities to the balance sheet.
- Sample, PREQ with relieved encumbrance:

Purchase Order Line Item Totals	
Encumbrance excluding freight & s/h	Total Encumbrance Amount Relieved
179.00	179.00

- Sample: General Ledger Pending entries on approved PREQ (encumbrance and initial offset from PO are reversed. Expense applied with offset to Acct Payable/liability object code 9041):

General Ledger Pending Entries				
Seq #	Fiscal Year	Chart	Account Number	Sub-Account
1	2012	BL	2947482	----
2	2012	BL	2947482	----
3	2012	BL	2947482	----
4	2012	BL	2947482	----

Notes and Attachments (0) [▶ show](#)

Ad Hoc Recipients [▶ show](#)

Route Log [▶ show](#)

For all of the above transactions (Requisition to Purchase Order to Receiving to Payment Request), a user can see how the transactions post to the general ledger during the course of one day, i.e. if all docs created in same day, but including filter **All** on balance inquiry searches.

Tip

OLE is cloud-based, allowing users to have multiple browser windows open. If a user wants to query multiple Account-Objects for available balances, while having a transaction open in another window- that user could jump through multiple queries or details in one window, then just copy/paste preferred Chart, Account, Object codes into the Accounting lines of an open transactional document in another window- Requisition, Purchase Order, Payment Request, Transfer of Funds etc.

GL Inquiries: Basic Information

Entering Lookup Criteria

After you select the desired inquiry, you are taken to the lookup criteria screen. The lookup criteria may display some default values, which you may change. To view all General Ledger balances on a specific account you need to enter just the chart and the account number. You can be more specific by including additional criteria. To view specific sub-accounts, object codes or sub-object codes you may enter these criteria. On some of the inquiry screens the balance type may be changed to view something other than actual balances. For example, to view budget transactions, you can change the balance type to either 'CB' (current budget), 'BB' (base budget), or 'MB' (monthly budget which may not be available on all accounts).

The following is an example of the lookup criteria screen for the General Ledger Balance Lookup.

General Ledger Balance Lookup

* Fiscal Year:	<input type="text" value="2010"/>
* Chart Code:	<input type="text"/>
* Account Number:	<input type="text"/>
Sub-Account Number:	<input type="text"/>
Object Code:	<input type="text"/>
Sub-Object Code:	<input type="text"/>
Balance Type Code:	<input type="text" value="AC"/>
Object Type Code:	<input type="text"/>
Consolidation Option:	<input checked="" type="radio"/> Consolidation <input type="radio"/> Detail
Amount View Option:	<input checked="" type="radio"/> Monthly <input type="radio"/> Accumulate
Include Pending Ledger Entry:	<input checked="" type="radio"/> No <input type="radio"/> Approved <input type="radio"/> All

Click when you have entered all necessary criteria and are ready to retrieve the balances.

Meaning of Dollar Accumulators

The inquiries contain various dollar accumulators. The following describes the meaning of each of the amounts displayed in the inquiry results, and which inquiries contain the bucket type.

Dollar Accumulator definition

Column Title	Description
Account Line Annual Balance Amount	The total amount of activity in this account for this balance type across all periods of the selected fiscal year. Appears in Cash Balances inquiry and the General Ledger Balance inquiry.

Purchasing/Accounts
Payable Maintenance E-Docs

Actual Amount	The total of all actual activity for a given balance line of the selected fiscal year. Appears in Available Balances inquiry and Balances by Consolidation inquiry.
Available Cash Balance	The total of the beginning balance and the year-to-date balance. Appears in the Cash Balances inquiry.
Beginning Balance Line Amount	The amount in this account for this balance type and object code at the beginning of the selected fiscal year. Appears in the General Ledger Balance inquiry.
[Month] Balance Amount	The total of all activity for a given accounting period. These fields are labeled as the month to which they refer (July, August, September, etc.).
Budget Amount	The current budget amount in this account for the selected fiscal year. Appears in Available Balances inquiry and Balances by Consolidation inquiry.
Closed Amount	The amount of the encumbrance that has been closed. Appears in the Open Encumbrances inquiry.
Contracts Grants Beginning Balance Amount	The cumulative amount in this account for this balance type and object code that was carried forward from the previous fiscal year. Appears in the Cash Balance inquiry and the General Ledger Balance inquiry.
Encumbrances Amount	The total of all encumbrance activity for a given account for the selected fiscal year. Appears in Available Balances inquiry and Balances by Consolidation inquiry.
Ledger Entry Amount	The dollar amount associated with a particular ledger entry. Appears in General Ledger Entry inquiry and Pending General Ledger Entry inquiry.
Open Amount	The amount of the original encumbrance. Subtracting the Closed Amount from the Open Amounts gives the amount of the encumbrance that is still outstanding. Appears in the Open Encumbrances inquiry.
Variance	The difference between the available budget and the actual amounts, plus encumbrances for an object code or category. Appears in Available Balances inquiry and Balances by Consolidation inquiry.

Drilldowns

The various inquiries display their initial balances at different levels of aggregation. You may drill down into detail when there is the **Drill Down** link available, or if the amount or other attribute (e-doc, for example) is a hyperlink. The following illustrations show the types of drilldowns available in the inquiries.

<u>Sub-Account Number</u>	<u>Reporting Sort Code</u>	<u>Consolidation Code</u>	<u>Lookup By Level</u>	<u>Budget Amount</u>
ALL	A	OTRE	Drill Down	0.00
ALL	B	TRVL	Drill Down	0.00

--

You may drill down to the next level from the **Drill Down** link.

<u>Chart Code</u>	<u>Account Number</u>	<u>Sub-Account Number</u>	<u>Object Code</u>	<u>Sub-Object Code</u>	<u>Balance Type Code</u>
<u>BL</u>	<u>1031400</u>	<u>*ALL*</u>	<u>8000</u>	<u>*ALL*</u>	<u>AC</u>

July	<u>0.00</u>	October	
August	<u>0.00</u>	November	
September	<u>1,365.55</u>	December	

You may drill down to the entries that make up the total from the amount link.

<u>Fiscal Period</u>	<u>Document Type Code</u>	<u>Origin Code</u>	<u>Document Number</u>	<u>Transaction Ledger Entry Description</u>	<u>Transaction Ledger Entry Amount</u>	<u>Debit Credit Code</u>
<u>03</u>	<u>CR</u>	<u>01</u>	<u>311498</u>	CR	250.55	C

You may drill down to the actual e-doc from the **document Number** link.

<u>Budget Amount</u>	<u>Actuals Amount</u>	<u>Encumbrance Amount</u>	<u>Variance</u>	<u>See Pending Entry</u>
<u>3,836,113.00</u>	<u>0.00</u>	<u>0.00</u>	3,836,113.00	<u>Drill Down</u>
<u>29,000.00</u>	<u>0.00</u>	<u>0.00</u>	29,000.00	<u>Drill Down</u>

Drill down to pending entry

Include or Exclude Pending Entries, Unapproved Entries, and GL Entries

Balance inquiries allow you to choose to include or exclude pending ledger entries. These entries have been generated by OLE documents that have not yet been posted through the GL accounting cycle. After a financial processing e-doc is saved, it generates pending ledger entries. These entries are considered pending until the document is disapproved (at which point they are removed) or the document is fully approved and the entries are posted to the General Ledger.

You can choose to exclude pending ledger entries (the default behavior), include all pending ledger entries, or include only those entries associated with documents that have been approved (documents that have reached 'Processed' or 'Final' workflow status).

Note

Including all pending ledger entries in an inquiry can generate misleading results. Note that choosing to include all pending ledger entries in a balance inquiry can generate misleading results because saved documents may contain incomplete or unbalanced accounting entries. Choosing to view all pending ledger entries should be done with the understanding that unapproved entries may change drastically prior to actually posting or they may not post at all.

Refer to the following chart to identify the inquiry that applies to your analysis.

Inquiry Drilldown Patterns

	By Consolidation	By Level	By Object	GL Balance	GL Entry Lookup	By e-doc
Available Balances				#	#	#
Cash Balances	Lists cash balances only (no drilldown)					
GL Balances				#	#	#
GL Entry					#	#
GL Pending Entry					#	#
Open Encumbrances	Lists open encumbrance amounts only (no drilldown)					

General Ledger Entry

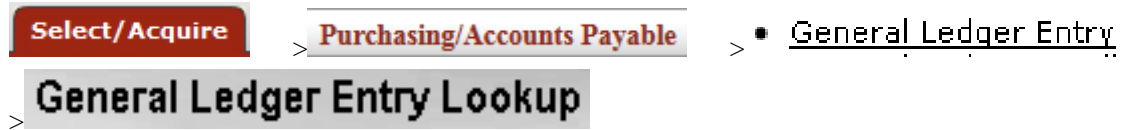

Note

For general information about entering lookup criteria, interpreting dollar accumulators, drilling down into inquiries to see more detail, and including or excluding pending entries, see [GL Inquiries: Basic Information](#).

The General Ledger Entry inquiry displays the individual transactions that make up the balance in an account. It is the same inquiry that can be displayed by drilling down into the General Ledger Balance report, but instead of drilling down from the General Ledger Balance screen you can go directly to this report by selecting it from the main Balance Inquires menu.

The drilldown pattern of this inquiry is as follows:

7. General Ledger Entry
8. E-Doc

Lookup Criteria

Fill in at least **Fiscal Year**, **Chart Code**, **Account Number**, and **Fiscal Period** or **Fiscal Year** and **Document Number**. The lookup criteria default to the current fiscal year, balance type of 'AC'(actuals), and the current fiscal period.

Use the lookup icon  as necessary to select the criteria. Select the desired **Pending Ledger Entry Approved Indicator** option. The Pending General Ledger inquiry offers two alternatives for including

the pending ledger entries: the ability to include all pending entries by selecting **All** or only those pending entries that are fully approved by selecting **Approved**. Cancelled and disapproved pending entries are not pulled into the balance inquiry results.

General Ledger Entry Lookup ?

Fiscal Year:	2010	Document Type:	
Chart Code:		Origin Code:	
Account Number:		Document Number:	
Sub-Account Number:		Organization Document Number:	
Object Code:		Project Code:	
Sub-Object Code:		Organization Reference Id:	
Balance Type Code:	AC	Reference Document Type Code:	
Object Type Code:		Reference Origin Code:	
Fiscal Period:	04	Reference Document Number:	
Pending Entry Approved Indicator:	<input checked="" type="radio"/> No <input type="radio"/> Approved <input type="radio"/> All		

Search Results

The inquiry results list the transactions that meet your lookup criteria. From here you can drill down into the e-doc that created the transaction.

Fiscal Year	Chart Code	Account Number	Sub-Account Number	Object Code	Sub-Object Code	Balance Type Code	Object Type Code	Fiscal Period	Document Type	Origin Code	Document Number	Transaction Ledger Entry Description	Transaction Ledger Entry Amount	Debit Credit Code	Transaction Date	Organization Document Number	Project Code	Organization Reference
2009	BL	1031400	4055	---	AC	EX	02	GEC	02	AQ1461304	Description Hidden	1,500.00	C	08/19/2003		-----	

E-Doc Drilldown

Clicking the document number link from the General Ledger Entry inquiry results allows you to open the underlying e-doc which makes up the transaction. You may view, copy or perform error correction once the document is open, within the constraints of your existing OLE role(s). Note that no link will be displayed if the document originates from a system other than OLE.

Available Balances

Select/Acquire
Purchasing/Accounts Payable

>
•
Available Balances
..>
Available Balances Lookup

Note

For general information about entering lookup criteria, interpreting dollar accumulators, drilling down into inquiries to see more detail, and including or excluding pending entries, see [GL Inquiries: Basic Information](#).

The Available Balances inquiry displays the cumulative balances for an account by object code. The drilldown pattern is as follows:

9. General Ledger Balance







10.GL Entry Lookup

11.E-Doc

Lookup Criteria

Fill in at least Fiscal Year, Chart Code and Account Number. Use the lookup icon  as necessary to select the criteria. Select the desired **Consolidation** and **Included Pending Entry** options.

Available Balances Lookup

* Fiscal Year:	2009 
* Chart Code:	BL 
* Account Number:	1031400 
Sub-Account Number:	<input type="text"/> 
Object Code:	<input type="text"/> 
Sub-Object Code:	<input type="text"/> 
Consolidation Option:	<input checked="" type="radio"/> Consolidation <input type="radio"/> Detail
Include Pending Ledger Entry:	<input checked="" type="radio"/> No <input type="radio"/> Approved <input type="radio"/> All

Search Results

The search results will show the amount of money that has been budgeted for this account broken down by Object Codes. To see further details including Actuals and Encumbrance Amounts, select **All** on the **Include Pending Ledger Entry** field and click the  button again.

You may drill into the amount column to view the details that make up the total amount.



Main Menu

Maintenance

Administration

action list doc search

Available Balances Lookup ?

* Fiscal Year:	2012
* Chart Code:	BL
* Account Number:	2947489
Sub-Account Number:	
Object Code:	
Sub-Object Code:	
Consolidation Option:	<input checked="" type="radio"/> Consolidation
Include Pending Ledger Entry:	<input type="radio"/> No <input type="radio"/> Approv

search clear cancel

4 items retrieved, displaying all items.

<u>Fiscal Year</u>	<u>Chart Code</u>	<u>Account Number</u>	<u>Budget Amount</u>	<u>Actuals Amount</u>	<u>Encumbrance A</u>
2012	BL	2947489	20,000.00	0.00	
2012	BL	2947489	20,000.00	0.00	
2012	BL	2947489	20,000.00	0.00	
2012	BL	2947489	20,000.00	0.00	

Export options: [CSV](#) | [spreadsheet](#) | [XML](#)

Each underlined piece of information in the results grid is an active URL which when clicked can provide you further details about each piece of information. For example clicking on the Actuals amount gives you a monthly breakdown of payment requests that have been processed.

For more information on drilldowns, see [above](#).

Query Available Account Balances: Requisition (Purchase Order, Payment Request) Line Item

Available Balance details can also be accessed from the Requisitions page by clicking on the **bal inquiry** button *after you have added an accounting line:*

Current Items					
Item Line #	Item Type	Quantity	No. of Parts	UOM	
Item 1					
	Qty	1.00	1	EA EACH	
Bib Info:		Bib Editor	create	Title	Frank Lloyd Wright
Options		Format		Category	
▶ show Notes					
▼ hide Accounting Lines					
Accounting Lines ?					
Source					
* Chart		* Account Number		Sub-Account	
[]		[]		[]	
* Chart		* Account Number		Sub-Account	
BL		2947489		[]	
BLOOMINGTON		FRENCH & ITALIAN			

Extended Cost	Tax Amount	Am
0.00	0.00	
Requestor		
[]		
Vendor It Identifie		
[]		
* Dollar \$		
0.00		
* Dollar \$		
0.00		100

From the **Balance Inquiry Report Menu**, select **Available Balances**:

Balance Inquiry Report Menu

- Available Balances** 🔍
- Balances by Consolidation** 🔍
- Cash Balances** 🔍
- General Ledger Balance** 🔍
- General Ledger Entry** 🔍
- General Ledger Pending Entry** 🔍
- Open Encumbrances** 🔍

To return to the requisition, click the button on each screen.

Globally Protected Field

Select/Acquire > Purchasing/Accounts Payable > Globally Protected Field >
Globally Protected Field Lookup > Globally Protected Field

The **Globally Protected Field** Maintenance Document is used to maintain the protected fields for importing files into the OLE DocStore. The globally protected fields contain MARC tags/indicators/subfields that should not be dropped from the MARC record but could be modified if indicated.

A list entry has several data elements: tag, first indicator, second indicator, (optionally) subfield code, and protection flag. Wildcards (for example: 01*, 9**, 050*) can be used anywhere except for the protection flag. The list entry will apply to all matching fields.

Note

Globally protected fields can be overridden through the load profile.

Document Layout

Globally Protected Field		Document Number
		Initiator Network
Document Overview		
* Description:	<input type="text"/>	Explanation:
Organization Document Number:	<input type="text"/>	<input type="text"/>
Add/Edit Globally Protected Field		
	Old	New
Tag:	790	<input type="text" value="790"/>
First Indicator:		<input type="text"/>
Second Indicator:		<input type="text"/>
Sub Field:		<input type="text"/>
Active Indicator:	true	<input checked="" type="checkbox"/>
Notes and Attachments (0)		
Ad Hoc Recipients		
Route Log		

The Globally Protected Field document includes the **Add/Edit Globally Protected Field** tab. The system automatically enters data into both the **Old** and **New** sections in this tab. Selected data fields are available for editing.

Add/Edit Globally Protected Field tab definition

Purchasing/Accounts
Payable Maintenance E-Docs

Title	Description
Tag	Required. The MARC tag that will globally protected during ingest.
First Indicator	Optional. The MARC first indicator that will be globally protected during ingest.
Second Indicator	Optional. The MARC second indicator that will be globally protected during ingest.
Sub Field	Optional. The MARC subfield that will be globally protected during ingest.
Active Indicator	Indicates whether this licensing requirement code is active or inactive. Remove the check mark to deactivate this code.

Chapter 14. Licensing Overview

Licensing is only a part of the Select and Acquire module. To learn more about module, see the *Select and Acquire Overview* from the [OLE Documentation Portal](#).

The Licensing process in OLE includes a back and forth negotiating process between the licensing institution and the electronic resource vendor to set the final terms of the license contract. This is intended to be completed whenever appropriate during the electronic resource acquisition process. OLE will store notes, data and attached documents from this licensing period in an electronic document, or e-doc, called a License Request.

Licensing workflows are a variable part of the electronic acquisitions process. Some resources do not require a license at all and can be used within the guidelines of copyright law, while others require extensive negotiation of business and licensing terms. In general, the licensing process consists of:

- Requesting a standard license from a publisher for a resource
- Assigning the license to a “shepherd” or license owner
- Comparing the license with standard requirements established by the institution and/or library
- Back and forth negotiation with the publisher / library administration to modify license language if necessary.
- If approval, final signatures from both parties.
- Storing final license document (generally a PDF) in OLE.
- Coding machine-readable interpretation of license terms in OLE via a license editor (will be stored as ONIX-PL in the Doctor). Note that this final step is planned for a future release.

The documents and workflows in the Licensing module will allow authorized users to gather information on available terms, store reference materials from providers, track and record external communications or “events,” and trace internal reviews, approvals, and signatures/signed agreements.

Note

In order to work efficiently in the system’s Licensing screens, you need to understand the basics of the user interface. For information and instructions on logging on and off, navigating, understanding the components of screens, and performing basic operations in the screens, see the [OLE Basic Functionality and Key Concepts](#).

Licensing e-documents

OLE Licensing utilizes e-documents and XML documents to store information about the Licensing process and all internal and external negotiations and communications. Initial OLE licensing will utilize:

- E-Resource Record to [initiate licensing workflows](#) by auto-creating the License Request when requested.
- [License Request](#) e-doc captures critical information and communication that takes place during vendor negotiations. It is used to create an institutional workflow for the license negotiation process.

- [Agreement Documents](#) (title lists, sample contracts, signed license, etc.) are external files that can be attached to License Requests
- ONIX-PL [Agreement](#) is used to record the interpreted terms of the license in a machine-readable format. Note that the Agreement is not available in the interface in 1.0, but the underlying infrastructure to import and store these documents has been created.
- [Maintenance Documents](#) & Code Lists

A License Request might be initiated for acquisitions of new titles, renewals of existing titles, or making changes to previous Agreements (amendments). OLE 1.0 provides for a License Request generated from an E-Resource Record as part of the acquisitions process. Future releases may address licensing for Addendums, Renewals, and Trials in more detail.

Chapter 15. Standard Licensing E-Docs

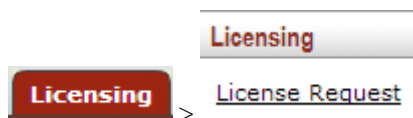

On the **Licensing** tab, the Licensing submenu allows users to view and maintain Licensing E-Docs.

Initiate License Workflow



For OLE 1.0, licensing and License Requests can be initiated from an **E-Resource** Record on the **Select/Acquire** tab.

When creating an E-Resource record, a user must click  to start the licensing workflow.

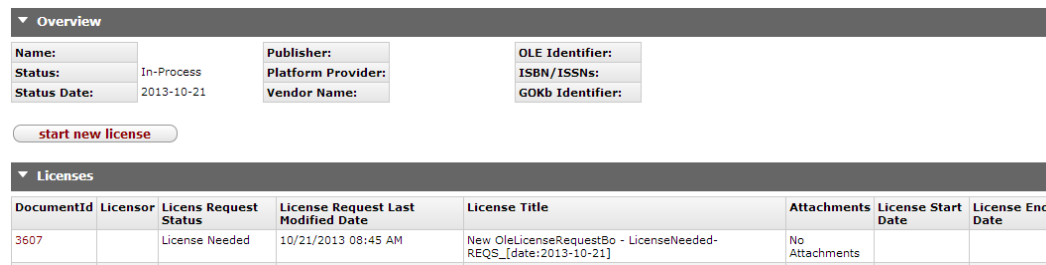

To open the newly created license, click on the Document ID. Alternatively, from the **Licensing** tab, click **License Request**.

Note

To learn more about the E-Resource Record, see the relevant section in the *Guide to OLE Select and Acquire*.

License Request

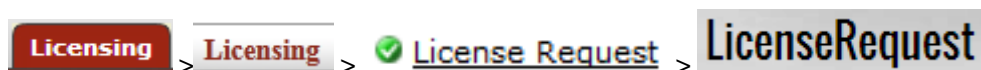

A License Request e-doc is a tool for collecting related information and documents during license investigations and negotiations. The License Request is a routable document, allowing various authorized users to complete workflow actions like reviews, approvals, signatures, or just notifications.

Note

License Requests will continue to be developed and modified in future releases.

Getting Started

Suggested roles and logins to test License Requests:

Role	Login
OLE_Licenses	fred
OLE_LicenseManager	frank

In order for a License Request to be created, the **start new license** box must be clicked on the **E-Resource Document's** Licenses tab. If this was done, staff may look for the License Request related to the E-Resource by clicking **License Request** under the **Licensing** header of the Licensing Menu.

Note

For information on searching, see [Searching OLE](#) on the *OLE E-Doc Fundamentals* wiki page.

Document Layout

LicenseRequest

▼ Document Overview

* Description: 

Organization Document Number:

▼ Overview

		Old	
Initiate Licensing Workflow:	License Needed	Owner/Assignee:	
Current Location:	Publisher	License Request Type:	
Agreement Method:			

▼ Event Log

Show entries

Type	Date/Time	* Staff	* Event Log/Notes
		admin 	
system	09/20/2013 09:47 AM	fred	License Request ini

Showing 1 to 1 of 1 entries

▼ Agreement Documents

Show entries

Date	User	* Agreement Type	* Agreement Document Title	* Attach File
		---	<input type="text"/>	<input type="button" value="Choose File"/> No file chosen

Showing 0 to 0 of 0 entries

▼ Agreement

		Old	
OldNew Find/Link Agreement:	OldNew Type Status Method	OldNew Find/Link Agreement:	OldNew
		<input type="text"/>	

▶ View Related Document

▶ Ad Hoc Recipients

▶ Route Log

The License Request document includes the **Overview**, **Event Log**, **Agreement Documents**, and **Agreement** tabs, in addition to the standard tabs.

Note

For information about the **standard tabs**, see [Standard Tabs](#) on the *OLE E-Doc Fundamentals* wiki page.

Overview Tab

The License Request contains a custom tab called the **Overview** that contains basic information about the License Request. The License Request status, agreement method (license, SERU, etc.) and the type of License Request (new, addendum, renewal) are noted here.

Tip

It is important to understand the workflow functions of licensing before working in the **Overview** tab. See [Workflows Overview](#) for more information about the license workflows steps.

▼ Overview		Old	
Initiate Licensing Workflow:	License Needed	Owner/Assignee:	
Current Location:	Publisher	License Request Type:	
Agreement Method:			

Document Overview Tabs Definitions

Title	Description
Initiate Licensing Workflow	Required. Select workflow to utilize for this License Request.
Current Location	Required. Select current location of the negotiation process or documentation (such as at Vendor, or at Campus Purchasing).
Agreement Method	Required. Describes the type of agreement being documented (negotiated, SERU, Copyright, etc.).
Owner/Assignee	Required. A combined list of all users in OLE_Licenses or OLE_LicenseManagers who can be “owners” for a License Request. Intended to be used to “assign” a License Request to a single user within a larger role or group.
License Request Type	Required. Indicates the type of this license negotiation process, whether new, renewal, or addendum.

Tip

Fields marked Required must be completed before the License Request can be submitted. The License Request can be saved without completing these fields.

Event Log Tab

The Event Log captures automated entries for workflow status changes, adding or linking Agreements or Agreement Documents. Users can also manually add entries to capture external communications, notes, or to summarize any actions external to OLE (such as with Vendor/Provider, University Legal, University Purchasing, etc.). You may add an event note by filling out the required fields and clicking  .

Many events can be recorded in the event log. You may display 10, 25, 50, or 100 entries at one time. Additionally, you may search for events from the search bar.

Event Log

Show entries

Type	Date/Time	* Staff	* Event Log/Notes
system	09/20/2013 09:47 AM	admin <input type="text" value="admin"/>	License Request initiated

Showing 1 to 1 of 1 entries

Event Log Tabs Definitions

Title	Description
Type	System generated. The event type value will be 'system' when the request is initiated, 'user' if a line was added manually by user; 'file' if an Agreement doc was added; 'agreement' if a linked Agreement document was edited or added; 'location' if a location change occurred; 'status' if a license status change occurred.
Date/Time	System generated. Logs the date and time for the event log line item.
Staff	Required. Logs the user id of the person associated with the event log change. Defaults to current user but can be modified by entering a name or searching from the lookup .
Event Log/Notes	Required; may be manually added or system generated. Users may input information to provide audit trail information. System also records what events have occurred.

Agreement Documents Tab

Throughout negotiations and investigations, various Licensing staff may need to upload or download miscellaneous documents. These are not restricted, and could be any documents that licensing staff wish to archive or share within the licensing process, such as Title Lists, Emails, Analytics or Statistics, sample agreements, signed and unsigned vendor agreements.

Agreement Documents should also be used to store updated Checklists used in the licensing process. Staff may download blank checklists from the [Manage Checklist](#) (Word documents, PDF Forms, Excel, etc.) and upload completed or in-progress Checklists to the License Request, specific to this negotiation process.

Agreement Documents

Show entries



Date	User	* Agreement Type	* Agreement Document Title	* Attach File
		---	<input type="text"/>	<input type="button" value="Choose File"/> No file

Showing 0 to 0 of 0 entries

Agreement Documents Tab Definitions

Title	Description
Date	System Generated. Date and time the document was uploaded.
User	System Generated. The name of the user who uploaded the file.
Agreement Type	Type of Agreement Document that has been uploaded. Samples from the dropdown list include Agent information, Checklist, or Email.
Agreement Document Title	Allows staff to identify a file with a short title.
Attach File	Select Browse to search for a document on your local computer and upload it to OLE Select Download attachment to open a document on your local computer.
Agreement Notes	Users may add quick summaries or other notes about the document
Agreement Version	If the same named document was uploaded more than once, users may keep track of multiple versions.
Action	Must choose add to attach the document to OLE or Delete to remove it.

To upload Agreement Documents:

1. Select an **agreement type** from the dropdown menu.
2. Enter a brief title for future search in the **Agreement Document Title** field.
3. Input any Notes about the document so that you will understand what it contains.
4. To select the document to upload, click on **Browse** to find your locally-saved file and select it for upload.
5. Click  to save the Agreement Document.
6. Click  at the bottom of the e-doc to save the License Request with the new Agreement Document.

To download Agreement Documents for Review or Edit:

Click **Download Attachments** to review and save a local copy.

▼ Agreement Documents

Show entries

Date ▲	User ▲	* Agreement Type ▲	* Agreement Document Title ▲	* Attach File	Agree
09/23/2013 03:18 PM	admin	Checklist ▼	T	<input type="button" value="Choose File"/> No file chosen <input type="button" value="download attachment"/> acknowledgements.jsp	

Showing 1 to 1 of 1 entries

Agreement Tab

As licensing investigations and negotiations workflows continue, staff may upload or link Agreements, or ONIX-PL format licenses. Users may use the Lookup to search for an existing Agreement to link to the License Request or create a new Agreement. The Agreement is an XML representation of the actual terms of the license itself.

Note

Although Agreements are not available as part of 1.0, future releases should allow staff to either upload an ONIX-PL document directly or use a license editor GUI to record license terms as an Agreement.

The screenshot shows a software interface with a tab labeled 'Agreement'. Below the tab are two panels. The left panel is titled 'New' and contains a text input field labeled 'Find/Link Agreement:' followed by a table with columns 'OldNew', 'Type', 'Status', and 'Method'. The right panel is titled 'Old' and contains a similar text input field and table structure.

Find/Link Agreement

Click on the Lookup  to search existing Agreements, and link to an existing Agreement for reference or future renewal or amendment. It is not possible to upload an Agreement in 1.0, so there are no Agreements to link to License Requests in this release. Users will also be able to create a new Agreement from this screen for this License Request in future releases.

The screenshot shows a window titled 'Agreement Search'. At the top left, it says 'Backdoor Id fred is in use'. The main area contains four input fields: 'Agreement Title:', 'Contract Number:', 'Licensee:', and 'Licensor:'. Each field has a small magnifying glass icon to its right. Below the fields are three buttons: 'search', 'clear values', and 'close'.

Process Overview

License Requests can be searched via the License Request menu selection.

1. Select the **Document Number** of the E-doc you wish to modify.
2. Add notes and/or agreement documents, or link to agreements as necessary.
3. Select the appropriate option for **Initiate Licensing Workflow**. See workflow information below.
4. Send ad hoc as necessary once the License Request status is enroute (a workflow must be initiated).

Warning

Known bug: The send ad hoc button is not working correctly. Rice developers are working to correct this error. To send ad hoc, users must add ad hoc recipients and **approve** the document.

This will send the document to the ad hoc recipient and then move the document to the next person of the workflow.

Click  or  as appropriate.

Business Rules

1. A License Request can link to none, one, or many Agreement Documents.
2. A License Request must have a License Request Type, an Agreement Method, a Current Location, and an Owner before submitting to a workflow.
3. A License Request can only have one Current Location.
4. A License Request can only have one current Owner.
5. A License Request can only have one current License Workflow.

Routing

The routing of License Request e-docs will be based on data values in the License Request, and will be initiated via user selection of a value from the **Initiate License Workflow** drop-down.

Workflows Overview

OLE will be pre-configured with some sample workflows and statuses to assist libraries in setting up initial Licensing processes.

Selected workflows, as defined below, will route the License Request to the selected Role to complete a desired action.

Tip

Reminder: A Role can be a single or many users.

Licensing Workflow Descriptions

Workflow Name	Workflow Description
Manual (Blank)	N/A, Self= No routing or workflow selection required. License Request will not become final with custom doc status "Complete" until an actual workflow is selected and completed.
Review Only	This workflow allows owners to route License Request to OLE_Reviewer (role) to complete reviews as defined in local policies (external to OLE)
Signatory Only	This workflow allows owners to route License Request to OLE_Signatory (role) to complete signatures of noted agreement Documents. This workflow requires ALL members of the signatory role to approve the License Request, indicating they have signed the document.
Approval Only	This workflow allows owners to route License Request to OLE_LicenseApprover (role) to approve the License Request.
Full Approval	This is full composite workflow (combining Signature workflow, university approval step, Review workflow, and Approval workflow),

	requiring all approvals and steps. Approval will be the last step, and based on Approved/Disapproved, complete the Licensing workflow.
Renewal*	This workflow is a modification to Full Approvals, and could be customized locally to fit Local Renewal approval policy.
Addendum*	This workflow is a modification to Full Approvals, and could be customized locally to fit Local Addendum approval policy.

Workflow Rules

1. As delivered, OLE Licensing workflows are optional, and are at the discretion of the owner of License Request to determine which workflow to initiate, based on knowledge of vendor and existing (external to OLE) policies.
2. Delivered OLE Licensing Workflows require that “Any” member of a Role defined in workflow must complete the Action for workflow and status to move forward, with the exception of “Signatory” workflows which require all Users defined in OLE_Signatory to complete the action.
3. OLE will offer combined and single PeopleFlows defined and editable by adopting libraries, with ability to use different metadata to establish rules for routing or available routing.
4. KRMS rules engine will pull metadata from the License Request and tell the system how to update statuses of related and linked documents, and which PeopleFlow workflows are enabled for the License Request.
5. OLE will currently only support a single active workflow at one time (future OLE may include recall/replace workflow options, or options to edit and initiate multiple simultaneous or sub-workflows.)
6. Each individual workflow will update License Request Custom Document Status.
7. OLE will provide sample workflows, roles, routing and UIs to act as template for locally configurable roles, workflows. Using KRMS and PeopleFlow, sites should be able to modify, add to, or remove steps or options in Licensing workflows, including additional rules or metadata conditions into KRMS agenda(s).

Note

Known bug: There is a bug being worked on in Rice that is preventing the “send adhoc” button to work. Users may send a license request only while approving a document.

Statuses & Workflow Definitions

License Request Manual Selection	E-Doc Custom Status	Description.	Description of the Workflow
License Needed	License Needed	Default custom doc status upon initiation.	N/A (manual status change only).
License Requested	License Requested	Manual custom doc status saved from "Initiate Licensing Workflow" selection.	N/A (manual status change only).
In Process	In Process	Manual custom doc status saved from "Initiate Licensing Workflow" selection.	N/A (manual status change only).
In Negotiation	In Negotiation	Manual custom doc status saved from "Initiate Licensing Workflow" selection.	N/A (manual status change only).
License Received	License Received	Manual status derived from "Initiate Licensing Workflow" selection, submitted by	Upon Submit, this concludes licensing investigations by OLE-Licenses, and license

Standard Licensing E-Docs

		OLE_Licenses for routing to OLE_LicenseManager.	request will route to "Owner" in OLE_LicenseManager role.
Review Only	Pending Review	Status when "Review Only" workflow selected from "Initiate Licensing Workflow", and submitted.	Initiate Licensing Workflow= Review Only. Status updates while pending outstanding review action by OLE-Reviewer.
--	Review Complete	Status when "Review only" workflow is completed by user approving License Request.	Initiate Licensing Workflow= Review Only. Status updates when outstanding review action by OLE-Reviewer is completed.
Signatory Only	Pending Signature	Status when "Signature Only" is selected from "Initiate Licensing Workflow" and submitted.	Initiate Licensing Workflow= Signature Only. Status updates while pending outstanding review action by OLE-Signatory.
--	Signature Complete	Status when "Signature Only" workflow is completed by OLE_Signatory and approved.	Initiate Licensing Workflow=Signature Only. Status updates when outstanding signature action by OLE-Signatory is completed.
<Current Location>	Pending University	Manual Status when University Approval step is required in Full Approval or Renewal workflows; routes to Owner/ OLE_LicenseManager.	Initiate Licensing Workflow= Full Approval. When combined workflow hits University approval step e-doc routes to owner, and goes to Pending University status.
--	University processing complete	Status when Owner/ OLE_LicenseManager approves License Request to complete University approval workflow step.	Initiate Licensing Workflow= Full Approval. When combined workflow hits University approval step (above) and Owner approves to indicate when university purchasing is complete.
Approval Only	Pending Approval	Status when "Approval only" workflow selected from "Initiate Licensing Workflow" and submitted.	Initiate Licensing Workflow= Approval Only. Status updates while pending outstanding Approval action by OLE-Licensing Approver.
Full Approval	<varies>	Status will update based on current action pending or most recent action completed. "Full Approval" is a composite workflow, and sequentially processes all 3 primary workflows: Review Only, then Signatory Only, and finally Approval Only. It also includes a "University Approval step between Review and Signatory workflows.	Initiate Licensing Workflow=Full Approval. Status updates when approval actions are taken.
Complete	Complete	Status when "Approval Only" workflow is completed by OLE_LicensingApprover via "Approve" button.	Initiate Licensing Workflow=Approval Only. Status updates when outstanding approval action by OLE_LicensingApprover is completed. Should report to Requisition.
Failed	Negotiation Failed.	Status when "Approval only" workflow is completed by OLE_LicensingApprover role via "Disapprove" button.	Initiate Licensing Workflow=Approval Only. Status updates when outstanding approval action by OLE_LicensingApprover is completed. Should report to Requisition.
--	<exception>	Something fails in workflow, License Request returns to Owner. Owner can re-select workflow and Submit again.	

Initiating Workflow

To select and initiate workflows, authorized users are able to select from drop-down selections (as defined above and below) and click on "Submit" at bottom of License Request to initiate the workflow request.

▼ Overview			
		Old	
Initiate Licensing Workflow:	License Needed	Owner/Assignee:	
Current Location:	Publisher	License Request Type:	
Agreement Method:			
Initiate Licensing Workflow:	License Received	Owner/Assignee:	frank
Current Location:	Publisher	License Request Type:	New
Agreement Method:	SERU		

Manual changes to Status/Initiate Licensing Workflow will also update the status of the License Request that will be seen by anyone who views the License Request, or sees it listed in Search Results or Action Lists, to assist in managing staff expectations and assignments across multiple License Requests (status will tell them where each License Request is in progress).

Workflow Options

Phase I:

Description: Selection staff believes title requested will require a License/Agreement.

Action(s): Staff member clicks ‘start new license’ button on the appropriate E-Resource :

1. System auto-routes to Action List of all members of OLE_Licenses.
2. Custom Doc Status= License Needed.

Phase II:

Description: Investigations, gathering documentation

Action(s): **OLE-Licenses** role fills in missing data on License Request, communicates with Vendor/ Provider, and uploads Agreement Documents, or creates/links draft Agreement/ONIX-PL.

3. Workflow/Status Options:

- License Needed. License Request “save”. No routing, License Request Custom doc status is updated.
- License Requested. License Request “save”. No routing, License Request Custom doc status is updated.
- In Process, or In Negotiation. License Request “save”. No routing, License Request Custom doc status is updated.
- License Received. Member of OLE_Licenses fills in required metadata, changes “Owner” to a member of OLE_LicenseManager, and “Submits” License Request. License Request removed from OLE_Licenses Action List and routed to the selected Owner in OLE_LicenseManager role.

Phase III:

Description: Negotiations & Pre-Contracting

Action (s): Specific user in **OLE_LicenseManager** now is “Owner” of License Request and is responsible in OLE for completing all licensing and negotiations.

4. Permitted user for editing: Any user in role OLE_Licenses, OLE_LicenseManager, OLE_LicenseReviewer, or OLE_LicenseConfiguration.
5. Can select any statuses in “Initiate Licensing Workflow” and Save License Request in order to update License Request custom doc status to describe repeating steps (i.e., negotiation process and therefore statuses may go back and forth).
6. Additional Workflow options:
 - Review Only: Initiate a review only workflow by selecting “Review Only” and “Submit”. License Request will Route to/appear in Action List of OLE_Reviewer. OLE_Reviewer (any user available in role to complete action) can review license request or linked Agreement or Agreement Documents, upload or replace new versions of Agreement Documents- including local Checklists. OLE_Reviewer can continue to modify via “Save”, and only “Approve” when all Reviews complete. License Request will route back to Owner for final approval and completion.
 - Signatory Only: Initiate a signatory only workflow by selecting “Signatory Only” and “Submit”. License Request will Route to/appear in Action List of OLE_Signatory. OLE_Signatory (all users defined in role to complete action) can review license request or linked Agreement or Agreement Documents; and, download, and upload signed documents. OLE_Signatory can continue to modify via “Save”, and only “Approve” when all required documents signed, uploaded and reviews complete. License Request will route back to Owner.
 - Approval Only: Initiate Approval step by selecting “Approval Only” and “Submit”. License Request will Route to/appear in Action List of OLE_LicensingApprover. OLE_LicensingApprover (any user available in role to complete action) can review license request or linked Agreement or Agreement Documents. OLE_LicensingApprover can continue to modify via “Save”, and only “Approve” or “Disapprove” when review is complete. This will complete the License Request workflow.
 - Full Approval: Full Approval workflow combines a sequence of above- first routing to OLE_Reviewer. When Approved system routes to OLE_Signatory. When Approved, routes to OLE_LicensingApprover. If Disapproved, status will go to “Negotiation Failed.” If License Request Approved, then workflow is complete and status goes to “Complete”.
 - Complete: Any licensing workflow (Signatory only, Approval only, Review only, etc.) is completed
 - Negotiation Failed. Any licensing workflow (Signatory only, Approval only, Review only, etc.) is disapproved at any approval step in the workflow.

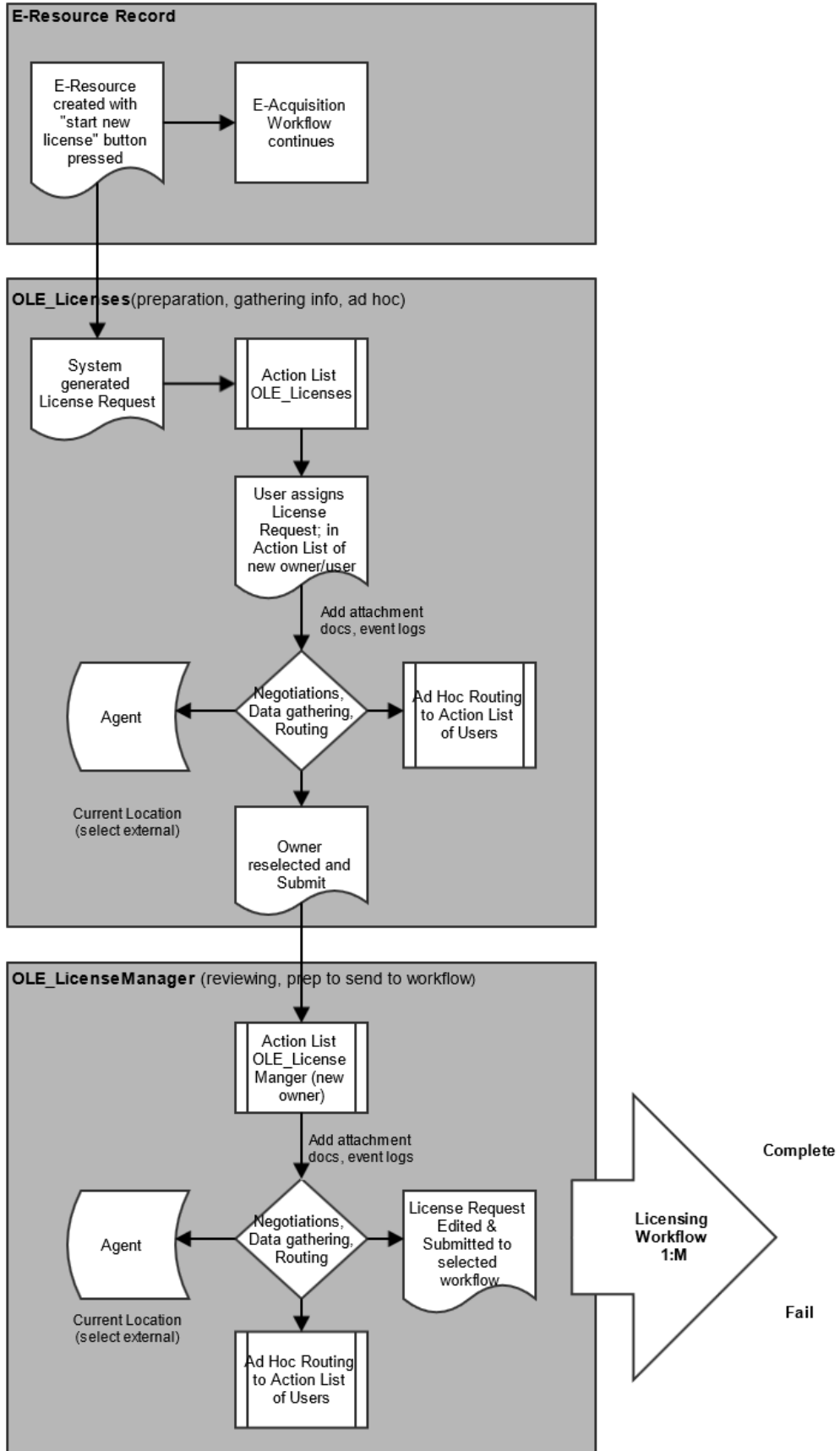

Note

To learn more about workflows, Action Lists, and Ad Hoc Routing, see [OLE Workflow Overview and Key Concepts](#) wiki page.

Chapter 16. License Maintenance Documents

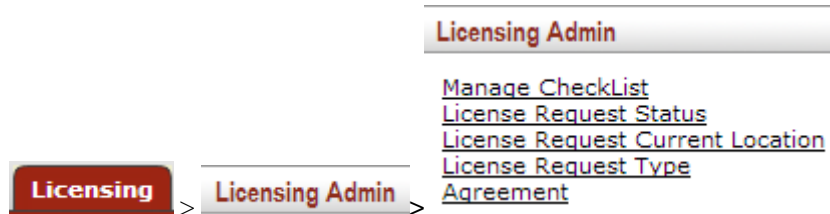

Licensing maintenance e-docs are available via the Licensing Admin submenu on the **Licensing** menu tab.

Roles & Permissions

All licensing maintenance documents are only editable by the Role, **OLE_LicenseConfiguration**. Users in this role can edit, create new, any actions via Blanket Approve.

Manage Checklist

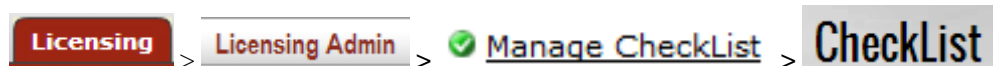

Checklists contain the list of local institutions' contractual requirements, and can be downloaded for use with individual License Requests. The basic checklists will contain action lists, compliancy checks, or internal policies for different types or Agreements. Users may attach locally-downloaded and filled-in copies to specific License Requests in 1.0.

Note

To upload completed Checklists to License Request negotiations, see [Agreement Documents Tab](#).

Document Layout

CheckList		Document Number: 564
		Initiator Network Id: adn
▼ Document Overview		
* Description:	test	Explanation:
Organization Document Number:		
▼ Add/Edit/Delete Check List		
* CheckList Name:		
CheckList Description:		
File Name:		
* Attach File:	Choose File No file chosen	
Active Indicator:	<input checked="" type="checkbox"/>	
▶ Ad Hoc Recipients		
▶ Route Log		

The Manage Checklist document includes the **Add/Edit/Delete Checklist** tab. The system automatically enters data into both the **Old** and **New** sections. Selected data fields are available for editing.

Add/Edit/Delete Check List Tab Definitions

Title	Description
CheckList Name	Required. A user-provided short name for the checklist, and easy search and retrieval in future.
CheckList Description	Detailed description that may explain when, where to use this checklist versus another. Purpose.
File Name	Name of the file associated with this checklist.
Attach File	Browse to select checklist to upload.
Active Indicator	Indicates whether this checklist is active or inactive. Remove the check mark to deactivate.

Process Overview

Checklist maintenance and the Checklist Maintenance e-doc can be undertaken to:

- Create/Upload new checklists
 - Enter the required fields.
 - Attach a file from your local computer.

Click  .

Ad Hoc route the document as needed.

Click  .

- Download & utilize local copy of checklist
Search for the checklist you wish to use.
Click on the **checklist name** to download the file.

- Delete a checklist
Search for the checklist you wish to delete.
Click **delete** in the actions column.

- Activate/Re-activate a checklist
Search for the checklist you wish to activate/re-activate.
Click **edit** in the actions column.
Check the **Active Indicator** box.

Click  .

- Overlay/Replace a checklist
Search for the checklist you wish to activate/re-activate.
Click **edit** in the actions column.
Browse for a new file to attach.

Click  .

License Request Status



License Request Status is used to describe the status of the License Request as it moves through the workflow of requesting, negotiating, and documenting a license. Licensing staff use the License Request Status document on License Request to manually select and label the status of the license request for easier

search, and management of Action Lists. Some statuses will NOT be available to the License Request, as they will be system-statuses only, such as at completion of a system-defined PeopleFlow/workflow step.

Note

Only those License Request Statuses not associated with completion of system-configured workflows will be available for manual selection on the License Request e-doc.

Document Layout

License Request Status		Document Number: 5644
		Initiator Network Id: admin
▼ Document Overview		
* Description:	<input type="text"/>	Explanation:
Organization Document Number:	<input type="text"/>	
▼ Add/Edit License Request Status		
	Old	New
Code:	IN	<input type="text" value="IN"/>
Name:	In Negotiation	<input type="text" value="In Negotiation"/>
Description:	In Negotiation	<input type="text" value="In Negotiation"/>
Active Indicator:	true	<input checked="" type="checkbox"/>
▶ Notes and Attachments (0)		
▶ Ad Hoc Recipients		
▶ Route Log		

The License Request Status document includes the **Add/Edit License Request Status** tab. The system automatically enters data into both the **Old** and **New** sections. Selected data fields are available for editing.

Add/Edit License Request Status Tab Definitions

Title	Description
Code	Required. Unique code for this status.
Name	Required. Brief name that will display anywhere status appears.
Description	Optional. Include a brief description.
Active Indicator	Indicates whether this status is active or inactive. Remove the check mark to deactivate.

License Request Current Location

[Licensing](#) > [Licensing Admin](#) > [License Request Current Location](#) >

License Request Current Location

The License Request Current Location is the secondary status field on a License Request; would most commonly be used to describe where the License Request is when it has been assigned outside of the OLE system. Current Locations allow licensing staff to search / report / filter License Requests in order to see how many licenses are waiting for signature, waiting for vendor, etc. It also provides a more complete summary of the current status of the license, ex: at Publisher, Copyright Office, Campus Purchasing, etc.

Current Location may be set manually at any time throughout system workflows.

Document Layout

License Request Current Location		Document Number:	5645	D
		Initiator Network Id:	admin	Creat
Document Overview				
* Description:		<input type="text"/>		
Explanation:		<input type="text"/>		
Organization Document Number:		<input type="text"/>		
Add/Edit License Request Current Location				
	Old	New		
License Request Current Location Name:	Publisher	<input type="text" value="Publisher"/>		
License Request Current Location Description:	Publisher	<input type="text" value="Publisher"/>		
Active Indicator:	true	<input checked="" type="checkbox"/>		
Notes and Attachments (0)				
Ad Hoc Recipients				
Route Log				

The License Request Current Location document includes the **Add/Edit License Request Current Location** tab. The system automatically enters data into both the **Old** and **New** sections. Selected data fields are available for editing.

Add/Edit License Request Current Location Definitions

Title	Description
License Request Current Location name	Required. Brief name to appear in displays for the location.
License Request Current Location Description	Brief description for this licensing location value or its use. Required.
Active Indicator.	Indicates whether this is active or inactive. Remove the check mark to deactivate.

License Request Type

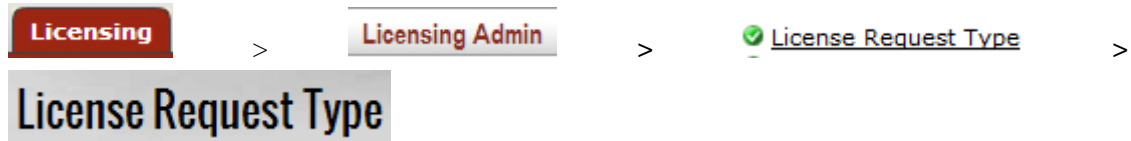

The License Request Type document is used to describe whether the request is a new request, a renewal, an amendment, or some of type of licensing change request.

The License Request Type will be used in configuring which workflows are valid for a specific License Request, along with Agreement Method and other metadata on the License Request.

Document Layout

License Request Type		Document Number:	5646	Do
		Initiator Network Id:	admin	Creat
Document Overview				
* Description:		<input type="text"/>	Explanation:	
Organization Document Number:		<input type="text"/>		
Add/Edit License Request Type				
	Old	New		
License Request Type Name:	New	<input type="text" value="New"/>		
License Request Type Description:	New	<input type="text" value="New"/>		
Active Indicator:	true	<input checked="" type="checkbox"/>		
Notes and Attachments (0)				
Ad Hoc Recipients				
Route Log				

The License Request Type document includes the **Add/Edit License Request Type** tab. The system automatically enters data into both the **Old** and **New** sections. Selected data fields are available for editing.

Add/Edit License Request Type Tab Definitions

Title	Description
License Request Type Name	Required. Brief Name for display.
License Request Type Description	Required. Brief description
Active Indicator	Indicates whether this license request is active or inactive. Remove the check mark to deactivate.

Chapter 17. Agreement Maintenance Documents



Agreement maintenance e-docs are available via the Agreement submenu on the **Licensing** menu tab.

Agreement Documents Type

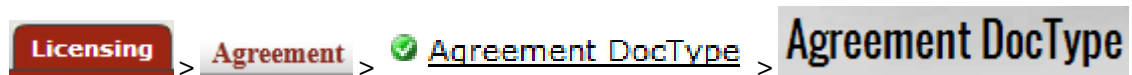

The Agreement DocType document is used to describe the type of Agreement Document that has been uploaded, allowing staff to easily identify the desired file out of possibly multiple files associated with an Agreement or License Request.

Document Layout

Agreement DocType		Document Number: 5642	Document
		Initiator Network Id: admin	Creation Tim

Document Overview	
* Description: test	Explanation:
Organization Document Number:	

Add/Edit Agreement Doc Type		
	Old	New
Agreement DocType Name:	Agent information	Agent information
AgreementDocType Description:	Agent information	Agent information
Active Indicator:	true	<input checked="" type="checkbox"/>

Notes and Attachments (0)
Ad Hoc Recipients
Route Log

The Agreement Document Type document includes the **Add/Edit Agreement Doc Type** tab. The system automatically enters data into both the **Old** and **New** sections. Selected data fields are available for editing.

Add/Edit Agreement Document Type Tab Definitions

Title	Description
Agreement DocType Name	Required. Brief name of Agreement document to display (such as title list, rider, etc.).
Agreement DocType Description	Required. Brief description of the Agreement document type.
Active Indicator	Indicates whether this Agreement DocType is active or inactive. Remove the check mark to deactivate.

Agreement Method

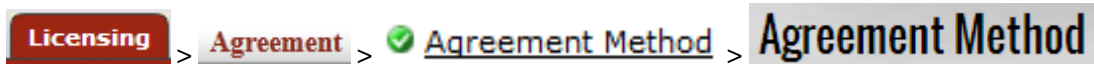

The Agreement Method document is used to store the form of the Agreement, and to inform locally-configurable business rules and workflows. This might contain negotiated, SERU, shrink-wrap, copyright, etc.

The Agreement Method is used in determining which workflows are valid for a specific License Request.

Document Layout

Agreement Method		Document Number: 5641	Document
		Initiator Network Id: admin	Creation Tim

Document Overview	
* Description:	Explanation:
Organization Document Number:	

Add/Edit Agreement Method		
	Old	New
Agreement Method Name:	Negotiated license	Negotiated license
Agreement Method Description:	Negotiated license	Negotiated license
Active Indicator:	true	<input checked="" type="checkbox"/>

▶ **Notes and Attachments (0)**

▶ **Ad Hoc Recipients**

▶ **Route Log**

The Agreement Method document includes the **Add/Edit Agreement Method** tab. The system automatically enters data into both the **Old** and **New** sections. Selected data fields are available for editing.

Add/Edit Agreement Method Tab Definitions

Title	Description
-------	-------------

Agreement Method Name	Required. Brief name for method (can use local or ONIX-PL suggested).
Agreement Method Description	Required. Brief description of the Agreement Method.
Active Indicator	Indicates whether this Agreement Method is active or inactive. Remove the check mark to deactivate.

Agreement Status

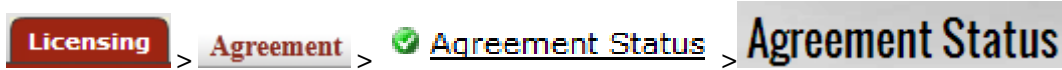

The Agreement Status document is used to communicate the current status of the Agreement (ONIX-PL.xml) in workflow or processing, such as: Active/Inactive, Draft, Final, or other status on Agreement.

Document Layout

Agreement Status		Document Number: 5640	Document
		Initiator Network Id: admin	Creation Time

Document Overview	
* Description: test	Explanation:
Organization Document Number:	

Add/Edit Agreement Status		
	Old	New
Agreement Status Name:	Draft	Draft
Agreement Status Description:	Draft	Draft
Active Indicator:	true	<input checked="" type="checkbox"/>

Notes and Attachments (0)
Ad Hoc Recipients
Route Log

The Agreement Status document includes the **Add/Edit Agreement Status** tab. The system automatically enters data into both the **Old** and **New** sections. Selected data fields are available for editing.

Add/Edit License Request Type Tab Definitions

Title	Description
Agreement Status Name	Required. Brief name to display.
Agreement Status Description	Required. Brief description of the agreement status.
Active Indicator	Indicates whether this Agreement Status is active or inactive. Remove the check mark to deactivate.

Agreement Type

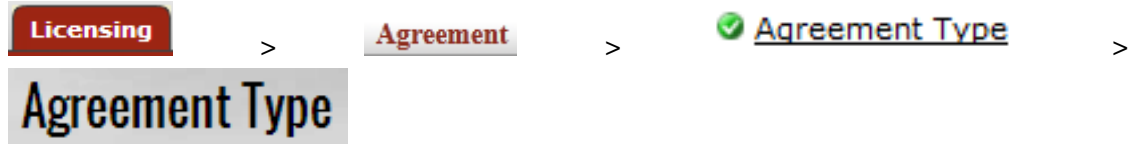

The Agreement Type document is used to communicate the Types of Agreements, such as supplemental, trial, regular, addendum, etc.

The Agreement Type and Agreement Method will be used in determining which workflows are valid for a specific License Request.

Document Layout

Agreement Type		Document Number: 5639	Document S
		Initiator Network Id: admin	Creation Times

Document Overview	
* Description:	<input type="text"/>
Organization Document Number:	<input type="text"/>
Explanation:	<input type="text"/>

Add/Edit Agreement Type		
	Old	New
Agreement Type Name:	Supplemental	<input type="text" value="Supplemental"/>
Agreement Type Description:	Supplemental	<input type="text" value="Supplemental"/>
Active Indicator:	true	<input type="text" value="true"/>

Notes and Attachments (0)
Ad Hoc Recipients
Route Log

The Agreement Type document includes the **Add/Edit Agreement Type** tab. The system automatically enters data into both the **Old** and **New** sections. Selected data fields are available for editing.

Add/Edit License Request Type Tab Definitions

Title	Description
Agreement Type Name	Required. Brief name for display.
Agreement Type Description	Required. Brief description to explain use of Agreement Type.
Active Indicator	Indicates whether this license request is active or inactive. Remove the check mark to deactivate.

Chapter 18. Appendix

Terms and Definitions

Term	Definition
Account	Identifies a pool of funds assigned to a specific university organizational entity for a specific purpose. Global document functionality is available for this document.
Agent	Any individual or organization entity that is represented in Kuali OLE. An agent could be an institution, a staff member, a library consortia, a publisher, a provider, or an individual working for a publisher / vendor. Synonyms: Vendor, Licensor, Publisher, Organization, Provider; Licensor or Licensee
Agreement	An agreement or understanding between the library / institution and a publisher / provider / donor regarding access to content. May include descriptive metadata, such as start date, end date, and contract number, as well as information about rights, restrictions, and business terms. An agreement will often represent either a negotiated license or a SERU agreement, although it could conceivably also represent other types of agreements, such as restrictions surrounding use of digital materials deposited in an institutional repository, use of donations made to a special collections unit, or use of gifts to the institution. Stored as DocStore .xml ONIX-PL. (Previous handoff for architecture. Future functional specification handoff for "Record License" with ONIX-PL license editor) Synonyms: Agreement Entity, License
Agreement Document	A file associated with an Agreement in OLE. Many types of files are utilized in the negotiation process / provide further details about an Agreement, including a variety of word processing files, spreadsheet files, and pdfs. Think: attachments, reference, title lists, SERU, checklists- primarily .doc, .xls, .pdf, but not limited by type. Synonyms: Agreement documents, attachments, linked files
Allocations	This is the primary area in which the ILS accounting is more granular and specific than at the parent organization level. A university will commonly budget operating funds for library acquisitions in one lump sum. The library then commonly subdivides that money into smaller chunks, according to the perceived needs of its users. The most common ways to subdivide the collection budget are: by school or administrative unit -- \$x for the School of Medicine, for instance, \$X for the School of Arts and Sciences, \$X for the Business School, etc.; by subject -- with the library deciding how many subject funds to subdivide the money into; by material type -- dividing the budget among monographs, print serials, e-serials, other e-resources, rare material, etc.; or by combinations of these categories.
Batch Job	Batch jobs, or batch processing, are what update General Ledger balances, other KFS/OLE tables, and files/jobs for exports. Batch jobs need to be run on some schedule to keep OLE in sync with external systems, such as University Financial.
Claim	The action (or a record thereof) of notifying a vendor that an ordered item has not been received for whatever reason. A claim can be made for a PO line item OR for a single issue of a serial title. Claims can be prompted by: non-receipt, receipt of the wrong version of an item, receipt of a damaged copy, etc.
Chart	The Chart document is used to define the valid charts that make up the high-level structure of the KFS Chart of Accounts. It also indicates who has management responsibilities for each chart and which object codes are used for system-generated accounting lines for the chart.
Checklist Template	A specific file (or files) that represents a university, library, or other institution's contractual requirements; licenses negotiated by the institution usually must meet (or attempt to meet) these specific requirements. Form of Agreement Document.
Commitments	This is a running total of costs expected in the future, from purchase orders that have been placed, but not yet paid for. Commitments are an inexact science, and their importance varies according to the types of purchases the library makes. Many libraries only use them for some types of orders (like firm orders, or print monographs), but don't use them at all for other types (like serial standing orders).

Appendix

DocStore	OLE architecture for structured and unstructured metadata (e.g., bib, item, holding, authority, licenses) that works in conjunction with linked transactional data in OLE RDBMS/relational tables (e.g., purchasing, circulation, users, financial, borrowers). Also referred to as the Document Store.
EDI	Electronic Data Interchange; structured transmission of data between organizations by electronic means. Usually a sequence of formatted messages between two parties. EDI formatted data can be transmitted using any methodology agreed to by the sender and recipient: FTP, HTTP, VAN, etc.
e-Doc	"electronic document", an online business transaction initiated in a Web-based form and routed electronically through a prescribed sequence of approvers. When the e-Doc has been through its entire approval process, it is maintained in a database for future reference. The OLE adaption of Kualiti Financial System (KFS) for Select and Acquire uses e-Docs.
EDIFACT	Electronic Data Interchange for Administration, Commerce and Transport, an EDI standard adopted by the United Nations.
EDIFACT Invoice Message	A file containing EDIFACT data for one or more vendor invoices.
Import	The act of importing and processing information from an external vendor; performing match-n-merge overlay; and creating appropriate documents inside OLE.
License	Generic term that reflects the final outcome or document- when a License is secured, the library may grant access to electronic resources for staff and patrons. The final License (future stories/specs) will likely be a signed and co-signed contractual Agreement between the Library and Agent, saved to DocStore, with its key terms reflected in the License/ONIX-PL editor.
Line Item	an entity to be ordered, usually identified by title on a purchase order; any purchase order can have more than one line item, e.g., 10 books on a purchase order = 10 line items, one for each. Intended for ease of purchasing multiple items from one vendor.
Negotiated License	One specific type of Agreement, which usually covers negotiated access to a purchased resource or collection of resources. The ONIX-PL standard was developed specifically to describe / transport both the text and interpretation of a negotiated license.
Object Code	Object codes represent all income, expense, asset, liability and fund balance classifications that are assigned to transactions and help identify the nature of the transaction Object Level. The Object Level document is used to maintain an attribute of the object code that is used to group similar object codes into categories for reporting Object Consolidation. The Object Consolidation document defines a general category of object codes for reporting. One object consolidation includes the object codes belonging to one or more object levels.
ONIX-PL	ONIX for Publications Licenses (ONIX-PL) is intended to support the licensing of electronic resources – such as online journals and eBooks – to academic and corporate libraries. ONIX-PL enables libraries to: (1) express licenses in a machine-readable format; (2) load them into electronic resource management systems; (3) link them to digital resources; and (4) communicate key usage terms to users. Publishers can also benefit from the ability to maintain their licenses in a standard machine-readable form.
Payment Method	The form of the desired or completed payment. Could be check (paper or ACH system), credit card/procard, wire transfer, cash, internal transfer/payment, foreign draft. Libraries will not process actual payments, but submit batch files to University for payment, and receive back confirming information.
Payment Request/Invoice	Vendor Invoices are processed thru an OLE Payment Request, and represent money owed/due to a Vendor for products or services.
Purchase Order	A document describing an entity to be bought or licensed along with vendor, fund, order type and other related data; OLE uses an adaptation of the Kualiti Financial System's purchase order.
Requisition	A pre-order document for a title being considered for acquisition as submitted by a library user or library staff using various input methods (e.g., submitting a Web form, manual keying, etc.) Default workflow is for a requisition to be approved by a selector and, upon supply of information such as vendor, fund, etc., be transformed into a purchase order. Selectors may also decide against acquisition and cancel the requisition with notice to the original requestor.

SERU	A statement (Shared Electronic Resource Understanding) that describes common understandings around e-resource subscriptions. This statement of common understandings can be used by libraries and publishers in place of a formal negotiated license.
Vendor	An organization or individual supplying materials for purchase, exchange or at no cost; KFS term is "supplier"

For additional OLE terms and definitions, see the [OLE glossary](#) wiki page.

Select And Acquire Roles

Below are some of the roles that will be authorized to use Purchasing and Accounts Payable Documents and related maintenance documents. Please see individual e-docs for specific requirements in each workflow.

Note

Sample users are provided for ease of testing and can be replaced with local library users.

Role	User ID	Permission Description
OLE_Load	ole-jpaul	Staff upload interface and Load Reports search
Accounting-AQ1	ole-brunelle	This Role is for View only document (Not for edit)
Accounting-AQ2	ole-cphovis	This Role is for low-level staff with specific needs only. This role is able to create and edit selected functions: payment requests, credit memos, disbursement vouchers, invoices)
Accounting-AQ3	ole-cstan; ole-durbin	This Role is for staff performing function. This role is able to create and edit all functions (payment requests, purchase orders, credit memos, disbursement vouchers, invoices).
Accounting-AQ4	ole-earley; ole-ecjacob	This Role is for when you want to restrict deletion to high-level staff. This role is able to create edit or delete all functions (payment requests, purchase orders, credit memos, disbursement vouchers, invoices, COA maintenance).
Acquisitions-AQ1	ole-brunelle	This Role is for View only document (Not for edit)
Acquisitions-AQ2	ole-cphovis; ole-ecjacob	This Role is for low-level staff with specific needs only. This role is able to create and edit selected functions (receiving, purchase orders, requisitions, payment requests).
Acquisitions-AQ3	ole-cstan; ole-durbin	This Role is for staff performing function. This role is able to create and edit all functions (receiving, purchase orders, requisitions, payment requests, vendors).
Acquisitions-AQ4	ole-cstan; ole-earley	This Role is for when you want to restrict deletion to high-level staff. This role is able to create edit or delete all functions (receiving, purchase orders, requisitions, payment requests, vendors, PURAP maintenance).
Acquisitions-AQ5	ole-ecjacob; ole-fermat; ole-flaherty	This role can perform functions and assign appropriate security level to others (receiving, purchase orders, requisitions, payment requests, vendors, PURAP maintenance).
Collection Manager	admin	This Role can close/cancel E-Resource Record if it is currently assigned to this group and Can approve/route to Acquisitions for purchase.
Financial-AQ1	ole-brunelle	This Role is for View only document (Not for edit)
Financial-AQ2	ole-cphovis	This Role is for low-level staff with specific needs only. This role is able to create and edit

Appendix

		selected functions (purchase orders, payment requests).
Financial-AQ3	ole-durbin; ole-fermat	This Role is for staff performing function. This role is able to create and edit all functions (purchase orders, payment requests, invoices).
Financial-AQ4	ole-earley; ole-ejacob	This Role is for when you want to restrict deletion to high-level staff. This role is able to create edit or delete all functions (budget documents, transfer funds, deposit documents, COA maintenance, purchase orders, payment requests, edit sufficient fund checks and restrictions).
Financial-AQ5	ole-cstan; ole-flaherty	This role can perform functions and assign appropriate security level to others (budget documents, transfer funds, deposit documents, COA maintenance, , purchase orders, payment requests, edit sufficient fund checks and restrictions).
Receiving-AQ1	ole-brunelle	This Role is for View only document (Not for edit)
Receiving-AQ2	ole-cphovis; ole-ejacob	This Role is for low-level staff with specific needs only. This role is able to create and edit selected functions (receiving).
Receiving-AQ3	ole-durbin	This Role is for staff performing function. This role is able to create and edit all functions (receiving, payment requests, purchase orders, invoices).
Receiving-AQ4	ole-cstan; ole-earley	This Role is for when you want to restrict deletion to high-level staff. This role is able to create edit or delete all functions (receiving, payment request, purchase orders, invoices, receiving maintenance).
OLE_Acquisitions-select	admin; admin1	This Role performs can create edit view but not delete E-Resource Records.
OLE_Cataloger	admin1	This role can only view E-Resource Record.
OLE_E-resource	admin	This role can create edit delete E-Resource Record start any sub-workflow link to GOKb particular focus is on Activation and using the AccessDashboard.
OLE_E-ResourceManager		This role manages site-wide configurations like values for the E-Resource status and time periods for alerts.
OLE_Head	admin	This Role performs can create edit view but not delete E-Resource Records.
[OLE-SELECT] Operator	dev2	Operator for Serial Receiving
OLE_Selectors	ole-cstan	Create requisitions No acquisitions authority-REQ would route to Acquisitions staff to complete. Use Order Holding Queue on own requisitions
OLE_Selectors_serial	ole-lreeder	(above, for continuing orders)
OLE_Super-Selectors	ole-mandrew	Same as Selectors, plus Assign any requisitions in OHQ
OLE-VND Reviewer	ole-eurainer ole-jtlieb ole-cofye	This role receives workflow action requests for the Vendor document.
OLE_Acquisitions	ole-fermat	All of above, plus processing Purchase Orders, Purchase Order Amendments, APO-automatic Purchase Orders, Vendor.
OLE_Acquisitions_serial	ole-smills	(above, for continuing orders)
OLE_ACQ-Mgr	ole-hachris, ole-kgeorge	All of above, plus approval actions for above users.
OLE_ACQ_mgr_serial	ole-bperser	(above, for continuing orders)

Appendix

BL (organization) Chart Manager	ole-cswinson	Derived role- approves Chart changes, or Organization changes on an Account, or Campus code changes
OLE-SYS- Org Reviewer	ole-cknotts (ACK) ole-smorell (APPROVE)	Changes to Accounts under BL organization, or changes that affect BL organization require these approvals.
Budget Reviewer	ole-butt	Default user/role charged with reviewing Purchase Order documents that exceed an account's sufficient funds balance (OLE is modifying code pending KFS 5 debugging of SFC).
Fiscal Officer	ole-rorenfro	Only Fiscal Officer has to approve account changes (based on name on account)
Account Supervisor	ole-jaraujo	
Account Manager	ole-rorenfro	
Sub-Fund Reviewer	ole-wakins	If sub-fund is present on Account, this is approver for changes.
Sub-Account Reviewer	ole-wjwitte (ACK) ole-gpbilly (APPROVE)	If sub-account changes made
Account Reviewer	N/A	N/A unless editing IU- University Level Chart. "BL" chart in sample data does not require, or defaults to Fiscal Officer.
Super user	ole-khuntley	
OLE_Licenses	fred	Standard user of License Request. Compiles initial documentation, notes. All edits to "owned/initiated" License Request documents. View, edit, create License Requests, upload Agreement docs
OLE_LicenseManager	frank	Owner of License Request and licensing workflows, becomes central point of contact for negotiations. View, Edit, Create License Requests, upload, download Agreement Docs
OLE_LicenseReviewer	edna	Must acknowledge or approve completion of Review of Agreement, Agreement Documents, or License Request. View, edit License Request; download & upload agreement docs.
OLE_Signatory	eric	Must download, sign, and upload signed copy of Agreement Documents to License Request from Licensor. View, Edit License Request, download/upload Agreement Documents.
OLE_Licensing_Approver	supervisr	Must Approve overall License Request, in order for library to enter into binding agreement with Licensor. Approve/Disapprove License Request. Permission to execute Action buttons. Cannot change or upload Agreement documents, or edit License Request metadata. Note Known bug: OLE_Licensing_Approver cannot add Event Log entries in 1.0.
OLE_LicenseViewer	kuluser (or any)	Users authorized to view Agreements, License Requests.
OLE_LicenseConfiguration	admin	System user who can setup licensing module, code lists, statuses, workflows, checklists.

		View, Edit, Create, delete Checklist, and manage any maintenance docs.
OLE_LicenseAssignee	OLE_LicenseManager	System grouping of authorized licensing roles that can be selected as "Owners" on License Request. Role/Group used to combine OLE Licenses and OLE License manager into single group for use in "Owner" options for License Request.
<any user-Action List>	<any Kuali user>	Agreements and Licenses will be highly controlled. Unlike other Searches or Document View-only documents in OLE, only users in above listed licensing roles can view any ERMS docs.

Maintenance Documents Permissions and Routing

Purchasing/Accounts Payable Maintenance Document Name	Edit/save/submit or Blanket approve permissions: *blanket approve available if no approver listed in next column	Routes for Approval to (if approval required):
Billing Address	OLE-Acquisitions	
Carrier	OLE-Acquisitions	
Category	OLE-Acquisitions	OLE-ACQ-Mgr
Exception Type	OLE-Receive	OLE-Receive-Mgr
Format Type	OLE-Acquisitions	OLE-ACQ-Mgr
Funding Source	OLE-PAYMENT	
Invoice SubType	OLE-PAYMENT	
Invoice Type	OLE-PAYMENT	
Item Price Source	OLE-Acquisitions	OLE-ACQ-Mgr
Material Type	OLE-Acquisitions	OLE-ACQ-Mgr
Note Types	OLE-Acquisitions	OLE-ACQ-Mgr
Order Type	OLE-Acquisitions	OLE-ACQ-Mgr
Payment Method	OLE-PAYMENT	
Purchase Order Item Status	OLE-Acquisitions	OLE-ACQ-Mgr
Receiving Address	OLE-Acquisitions, OLE-Selectors, OLE-Super Selectors, OLE-ACQ-Mgr	
Receiving line item Note Type	OLE-Receive-Mgr	
Receiving Threshold	OLE-PAYMENT, OLE-ACQ-Mgr, OLE-Receive-Mgr	
Request Source Type	OLE-Acquisitions	OLE-ACQ-Mgr
Requestor		
Requestor	OLE-Acquisitions, OLE-Selectors, OLE-Super Selectors, OLE-ACQ-Mgr	
Vendor Maintenance Document Name		
Commodity Code	OLE-Acquisitions	OLE-PAYMENT
Contact Type	OLE User	OLE-ACQ-Mgr
Contract Manager	OLE-Acquisitions	ole-khuntley
Cost Source	OLE-Acquisitions	OLE-ACQ-Mgr
Ownership Type	OLE-PAYMENT	
Ownership Type Category	OLE-PAYMENT	
Payment Terms Type	OLE-PAYMENT	
Phone Type	OLE-Acquisitions	
Shipping Payment Terms	OLE-PAYMENT	
Shipping Special Conditions	OLE-Acquisitions	

Appendix

Shipping Title	OLE-Acquisitions	
Vendor Search Alias Type	OLE-Acquisitions	

Role Name	Users
<i>OLE_Selectors</i>	ole-cstan, ole-khuntley
<i>OLE_Super-Selectors</i>	ole-mandrew, ole-khuntley
<i>OLE_Acquisitions</i>	ole-fermat, ole- khuntley
<i>OLE_ACQ-Mgr</i>	ole-hachris, ole- khuntley, ole-kgeorge
<i>OLE_Receive_Mgr</i>	ole-msmith, ole-jfunk, ole-khuntley
<i>OLE_Payment</i>	ole-abeal, ole-khuntley

Sample Codes

Sample Chart/Account Codes

Type	Chart	Account #	Name
university acct	BL	1047410	Library Monographs
university acct	BL	1047415	Library Serials
Fund code	BL	2947486	CHEMISTRY
Fund code	BL	2947482	EDUCATION
Fund code	BL	2947430	GEOLOGY
Fund code	BL	2947485	BIOLOGY
Fund code	BL	2947483	MEDICAL SCIENCES
Fund code	BL	2947498	COMM & CULTURE
Fund code	BL	2947499	CENTRAL EURASIAN
Fund code	BL	2947487	COMPARATIVE LIT
Fund code	BL	2947489	FRENCH & ITALIAN
Fund code	BL	2947488	FOLKLORE
Fund code	BL	2947491	HISTORY
Fund code	BL	2947492	HIST & PHIL OF SCI
Fund code	BL	2947493	LATIN AMERICAN
Fund code	BL	2947494	LINGUISTICS
Fund code	BL	2947495	RELIGIOUS STUDIES
Fund code	BL	2947496	SOCIOLOGY
Fund code	BL	2947490	SPEECH AND HEARING
Fund code	BL	2947497	SPANISH/PORTUGESE
Fund code	BL	2947484	COLLEGE OF ARTS AND SCIENCES
Fund code	BL	2947500	SCHOOL of MEDICINE

Object Code	Chart Name	Object Short Name	Object Name
7110	IU	MONO	MONOGRAPHS
7120	IU	SERIAL ACQ	SERIAL ACQUISITIONS
7100	BL	LIB ACQUIS	LIBRARY BOOKS
7110	BL	MONO	MONOGRAPHS
7112	BL	Mono Firm	Monograph Firm
7115	BL	Mono Appr	Monograph Approval
7120	BL	SERIALS	SERIALS
7122	BL	Serials Firm	Serials Firm

Appendix

7125

|BL

|Serials Appr

|Serials Approval

**Chart Codes with related Accounts/Object codes:
BUDGETS**

Chart Code	Account	Acct Name	Fiscal Year	Object	Object Name	CB Budget Amount
BL	2947486	CHEMISTRY	2012	7112	Monograph Firm	20,000
BL	2947486	CHEMISTRY	2012	7115	Monograph Approval	20,000
BL	2947486	CHEMISTRY	2012	7122	Serials Firm	20,000
BL	2947486	CHEMISTRY	2012	7125	Serials Approval	20,000
BL	2947482	EDUCATION	2012	7112	Monograph Firm	20,000
BL	2947482	EDUCATION	2012	7115	Monograph Approval	20,000
BL	2947482	EDUCATION	2012	7122	Serials Firm	20,000
BL	2947482	EDUCATION	2012	7125	Serials Approval	20,000
BL	2947430	GEOLOGY	2012	7112	Monograph Firm	20,000
BL	2947430	GEOLOGY	2012	7115	Monograph Approval	20,000
BL	2947430	GEOLOGY	2012	7122	Serials Firm	20,000
BL	2947430	GEOLOGY	2012	7125	Serials Approval	20,000
BL	2947485	BIOLOGY	2012	7112	Monograph Firm	20,000
BL	2947485	BIOLOGY	2012	7115	Monograph Approval	20,000
BL	2947485	BIOLOGY	2012	7122	Serials Firm	20,000
BL	2947485	BIOLOGY	2012	7125	Serials Approval	20,000
BL	2947483	MEDICAL SCIENCES	2012	7112	Monograph Firm	20,000
BL	2947483	MEDICAL SCIENCES	2012	7115	Monograph Approval	20,000
BL	2947483	MEDICAL SCIENCES	2012	7122	Serials Firm	20,000
BL	2947483	MEDICAL SCIENCES	2012	7125	Serials Approval	20,000
BL	2947498	COMM & CULTURE	2012	7112	Monograph Firm	20,000
BL	2947498	COMM & CULTURE	2012	7115	Monograph Approval	20,000
BL	2947498	COMM & CULTURE	2012	7122	Serials Firm	20,000
BL	2947498	COMM & CULTURE	2012	7125	Serials Approval	20,000
BL	2947499	CENTRAL EURASIAN	2012	7112	Monograph Firm	20,000
BL	2947499	CENTRAL EURASIAN	2012	7115	Monograph Approval	20,000
BL	2947499	CENTRAL EURASIAN	2012	7122	Serials Firm	20,000
BL	2947499	CENTRAL EURASIAN	2012	7125	Serials Approval	20,000
BL	2947487	COMPARATIVE LIT	2012	7112	Monograph Firm	20,000

Appendix

BL	2947487	COMPARATIVE LIT	2012	7115	Monograph Approval	20,000
BL	2947487	COMPARATIVE LIT	2012	7122	Serials Firm	20,000
BL	2947487	COMPARATIVE LIT	2012	7125	Serials Approval	20,000
BL	2947489	FRENCH & ITALIAN	2012	7112	Monograph Firm	20,000
BL	2947489	FRENCH & ITALIAN	2012	7115	Monograph Approval	20,000
BL	2947489	FRENCH & ITALIAN	2012	7122	Serials Firm	20,000
BL	2947489	FRENCH & ITALIAN	2012	7125	Serials Approval	20,000
BL	2947488	FOLKLORE	2012	7112	Monograph Firm	20,000
BL	2947488	FOLKLORE	2012	7115	Monograph Approval	20,000
BL	2947488	FOLKLORE	2012	7122	Serials Firm	20,000
BL	2947488	FOLKLORE	2012	7125	Serials Approval	20,000
BL	2947491	HISTORY	2012	7112	Monograph Firm	20,000
BL	2947491	HISTORY	2012	7115	Monograph Approval	20,000
BL	2947491	HISTORY	2012	7122	Serials Firm	20,000
BL	2947491	HISTORY	2012	7125	Serials Approval	20,000
BL	2947492	HIST & PHIL OF SCI	2012	7112	Monograph Firm	20,000
BL	2947492	HIST & PHIL OF SCI	2012	7115	Monograph Approval	20,000
BL	2947492	HIST & PHIL OF SCI	2012	7122	Serials Firm	20,000
BL	2947492	HIST & PHIL OF SCI	2012	7125	Serials Approval	20,000
BL	2947493	LATIN AMERICAN	2012	7112	Monograph Firm	20,000
BL	2947493	LATIN AMERICAN	2012	7115	Monograph Approval	20,000
BL	2947493	LATIN AMERICAN	2012	7122	Serials Firm	20,000
BL	2947493	LATIN AMERICAN	2012	7125	Serials Approval	20,000
BL	2947494	LINGUISTICS	2012	7112	Monograph Firm	20,000
BL	2947494	LINGUISTICS	2012	7115	Monograph Approval	20,000
BL	2947494	LINGUISTICS	2012	7122	Serials Firm	20,000
BL	2947494	LINGUISTICS	2012	7125	Serials Approval	20,000
BL	2947495	RELIGIOUS STUDIES	2012	7112	Monograph Firm	20,000
BL	2947495	RELIGIOUS STUDIES	2012	7115	Monograph Approval	20,000
BL	2947495	RELIGIOUS STUDIES	2012	7122	Serials Firm	20,000
BL	2947495	RELIGIOUS STUDIES	2012	7125	Serials Approval	20,000
BL	2947496	SOCIOLOGY	2012	7112	Monograph Firm	20,000

Appendix

BL	2947496	SOCIOLOGY	2012	7115	Monograph Approval	20,000
BL	2947496	SOCIOLOGY	2012	7122	Serials Firm	20,000
BL	2947496	SOCIOLOGY	2012	7125	Serials Approval	20,000
BL	2947490	SPEECH AND HEARING	2012	7112	Monograph Firm	20,000
BL	2947490	SPEECH AND HEARING	2012	7115	Monograph Approval	20,000
BL	2947490	SPEECH AND HEARING	2012	7122	Serials Firm	20,000
BL	2947490	SPEECH AND HEARING	2012	7125	Serials Approval	20,000
BL	2947497	SPANISH/ PORTUGESE	2012	7112	Monograph Firm	20,000
BL	2947497	SPANISH/ PORTUGESE	2012	7115	Monograph Approval	20,000
BL	2947497	SPANISH/ PORTUGESE	2012	7122	Serials Firm	20,000
BL	2947497	SPANISH/ PORTUGESE	2012	7125	Serials Approval	20,000
BL	2947500	LIBRARY ACQUISITIONS GENERAL	2012	7119	Mono Services	45,000
BL	2947500	LIBRARY ACQUISITIONS GENERAL	2012	7129	Serial Services	45,000
BL	1047410	Library Acquisitions	2012	7100	LIB ACQUIS	0

Sample Library (OLE) Organizations

CHART CODE	ORG CODE	ORG NAME
HIGHER LEVEL ORGANIZATIONS		
BL	LIBR	LIBRARY
BL	LACQ	LIBRARY ACQUISITIONS
OLE Level Organizations		
BL	BI	BIOLOGY - LIFESCI
BL	CHEM	CHEMISTRY - CHEM
BL	CMLT	COMPARATIVE LITERATURE - WELLS
BL	FOLK	FOLKLORE/ETHNOMUSICOLOGY - WELLS
BL	FRIT	FRENCH & ITALIAN - WELLS
BL	GEOL	GEOLOGICAL SCIENCES - GEOLOGY
BL	SPHS	SPEECH & HEARING - WELLS
BL	HIST	HISTORY - WELLS
BL	HPSC	HIST & PHIL OF SCIENCE - WELLS
BL	LNAM	LATIN AMERICAN - WELLS
BL	LING	LINGUISTICS - WELLS
BL	REL	RELIGIOUS STUDIES - WELLS
BL	SOC	SOCIOLOGY - WELLS
BL	SPAN	SPANISH & PORTUGUESE - WELLS
BL	CMCL	COMMUNICATION & CULTURE - WELLS
BL	CEUS	CENTRAL EURASIAN STUDIES - WELLS
BL	EDL	EDUCATION - EDUC

BL

MEDS

MEDICAL SCIENCES - LIFESCI

Document Statuses

Purchase Order Statuses

Code	Status
AMND	Pending Amendment
CANC	Cancelled
CGIN	Change in Process
CLOS	Closed
CLPE	Pending Close
CNCG	Cancelled Change
CXER	Error occurred sending cxml
CXPE	Pending cxml
DACG	Disapproved Change
DBUD	Disapproved Budget
DCG	Disapproved C & G
DCOM	Disapproved Commodity Code
DPUR	Disapproved Purchasing
DTAX	Disapproved Tax
FXER	Error occurred sending fax
FXPE	Pending Fax
INPR	In Process
OPEN	Open
PHOL	Payment Hold
PHPE	Pending Payment Hold
PRPE	Pending Print
QUOT	Out for Quote
RHPE	Pending Remove Hold
ROPE	Pending Reopen
RTPE	Pending Retransmit
RTVN	Retired Version
VOID	Void
VOPE	Pending Void
WBUD	Awaiting Budget Approval
WCG	Awaiting C & G Approval
WCOM	Awaiting Commodity Code Approval
WDPT	Waiting for Department
WNUI	Awaiting New Unordered Item Review
WPUR	Awaiting Purchasing Approval
WTAX	Awaiting Tax Approval
WVEN	Waiting for Vendor

Payment Request Statuses

Code:	Status:
ACHA	Awaiting Chart Approval

AFOA	Awaiting Fiscal Officer Approval
APAD	Awaiting AP Review
ARVR	Awaiting Receiving
ASAA	Awaiting Sub-Account Manager Approval
ATAX	Awaiting Tax Approval
AUTO	Auto-Approved
CANC	Cancelled
CIPR	Cancelled - In Process
DPTA	Department-Approved
INIT	Initiated
INPR	In Process
PEIN	Pending Route Electronic Invoice

Linked Resources

- [OLE Basic Functionality and Key Concepts](#).: E-Docs, action buttons- basic overview of elements
- [OLE Documentation Portal](#)
- [OLE Release Documentation](#) on the wiki
- [OLE Roadmap](#)
- [KFS Online Users Guide](#)
- [KFS Chart of Accounts](#)